

# **Eagle Power™**

## **Products Group**



### **450E**

### **AUTOMATIC**

### **SCRUBBER**

**ENTER** 

# **PARTS MANUAL**



Click on icon to return to this page.

← Back 1 page

## 450B - AUTOMATIC SCRUBBER

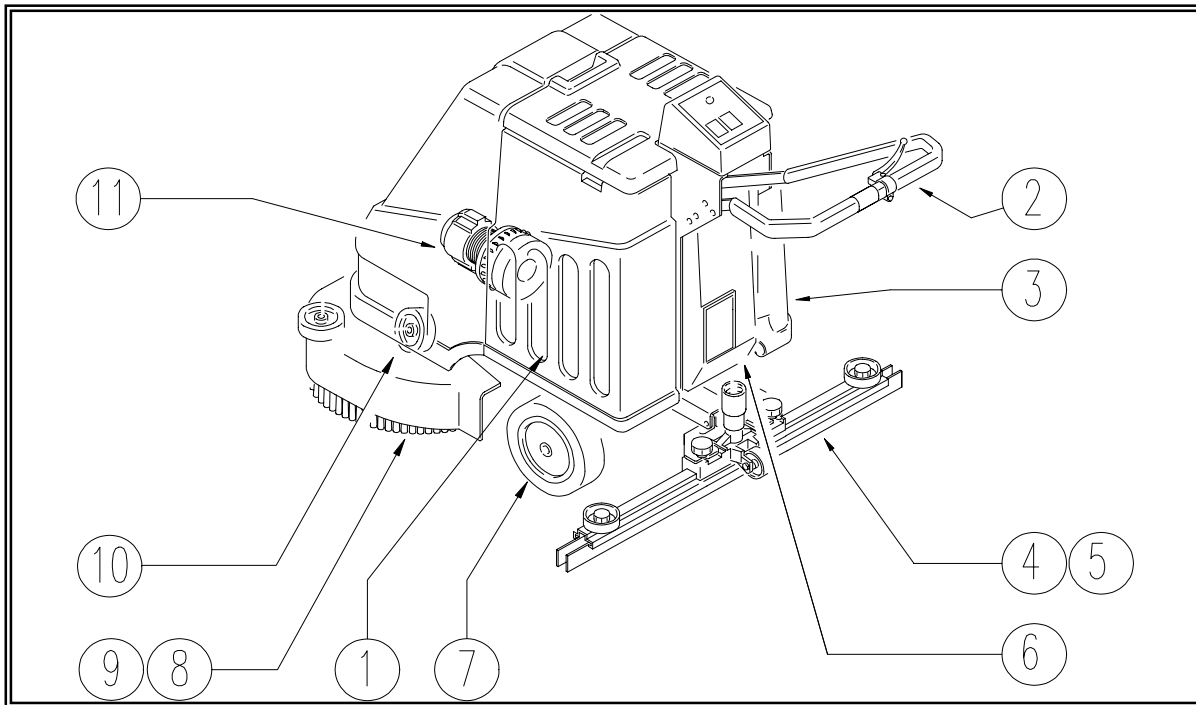

REF.	CODE	DESCRIPTION
1	<a href="#">PL1195</a>	LEFT TANK
2	<a href="#">PL1197</a>	HANDGRIP
3	<a href="#">PL1198</a>	RIGHT TANK
4	<a href="#">PL1214</a>	SQUEEGEE
5	<a href="#">PL1114C</a>	SQUEEGEE SUPPORT
6	<a href="#">PL1200U</a>	ELECTRIC UNIT
7	<a href="#">PL1169</a>	CHASSIS
8	<a href="#">PL1156</a>	PULLEY AXLE
9	<a href="#">PL1203UWS</a>	ELECTRIC MOTOR
10	<a href="#">PL1162</a>	PRESSURE WHEEL
11	<a href="#">PL1155L</a>	SUCTION
/	<a href="#">PL1205</a>	EXTERNAL PARTS
	<a href="#">WD27019</a>	ELEC. WIRING DIAGRAM
	<a href="#">EPF02215</a>	LABELS - DOCUMENTS
	<a href="#">IPF02215</a>	PACKING



← Back 1 page

**450E Automatic Scrubber CODE: pl1195 ad SN from 01A01**

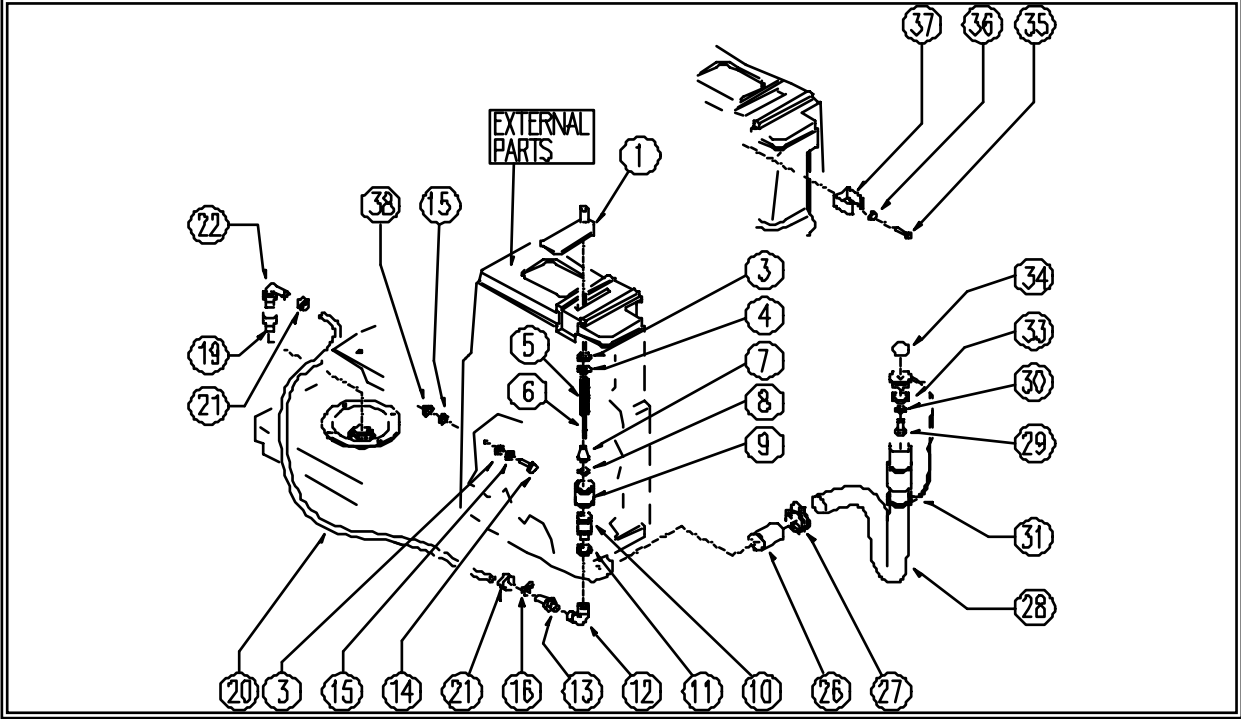

**450E Automatic Scrubber CODE: pl1195 ad SN from 01A000**

REF	CODICE	DESCRIPTION	QTY
1	SL17140-1K	LEVER / CURSOR	1
3	SL03122	WASHER	2
4	SL06071	WASHER	1
5	SL13032	SPRING	1
6	SL09381	TIE ROD	1
7	SL07250	SHUTTER	1
8	SL03149	GASKET	1
9	SL18137	FILTER	1
10	SL07249	TAP	1
11	SL03058	GASKET	1
12	SL18130	UNION / CONNECTOR	1
13	SL18150	UNION / CONNECTOR	1
14	SL04145	SCREW	1
15	SL06025	WASHER	2
16	SL1415C	CLAMP	1
19	SL1825E	UNION / CONNECTOR	1
20	SL1924C	HOSE	1
21	SL14109	CLAMP	2
22	SL18232	UNION / CONNECTOR	1
26	SL0351E	SHEATH	1

Next page →



← Back 1 page

450E Automatic Scrubber CODE: p11195 ad SN from 01A000			
REF	CODICE	DESCRIPTION	QTY
27	SL14063	CLAMP	1
28	SL19113-	HOSE	1
29	SL04002	SCREW	1
30	SL06022	WASHER	1
31	SL14237	CAP	1
33	SL03315	GASKET	1
34	SL20015	KNOB (o HANDWHEEL)	1
35	SL0417€	SCREW	2
36	SL0605€	WASHER	2
37	SL13014	DUCT LOCK	1
38	SL05039	NUT	1



450E Automatic Scrubber CODE: pl1197 ac SN from 01A000

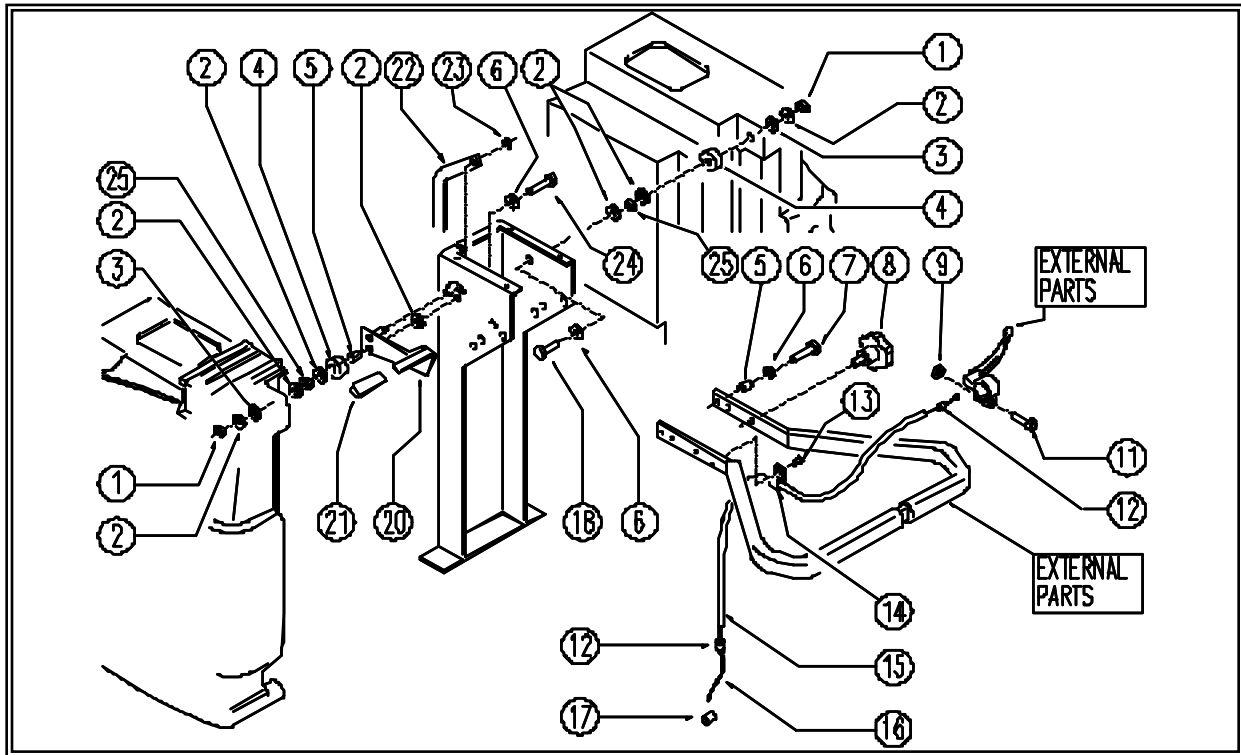

REF	CODE	DESCRIPTION	QTY
1	SL05039	NUT	2
2	SL06025	WASHER	7
3	SL03122	WASHER	2
4	SL07209	SPACER	2
5	SL07150	BUSHING	3
6	SL06041	WASHER	4
7	SL04203	SCREW	2
8	SL20012	HANDLE	2
9	SL05057	NUT	1
11	SL04063	SCREW	1
12	SL14116	BUSHING	2
13	SL04079	SCREW	1
14	SL14146	EYELET	1
15	SL14100	SHEATH	1
16	SL14143	CABLE	1
17	SL14141	CLAMP	1
18	SL04155	SCREW	1
20	SL09410K	LEVER	1
21	SL20021	HANDLE	1
22	SL09547	TIE-ROD	1
23	SL05041	RING	1
24	SL04164	SCREW	1
25	SL05001	NUT	2



← Back 1 page

**450E Automatic Scrubber CODE: pl1198 ac SN from 01A000**

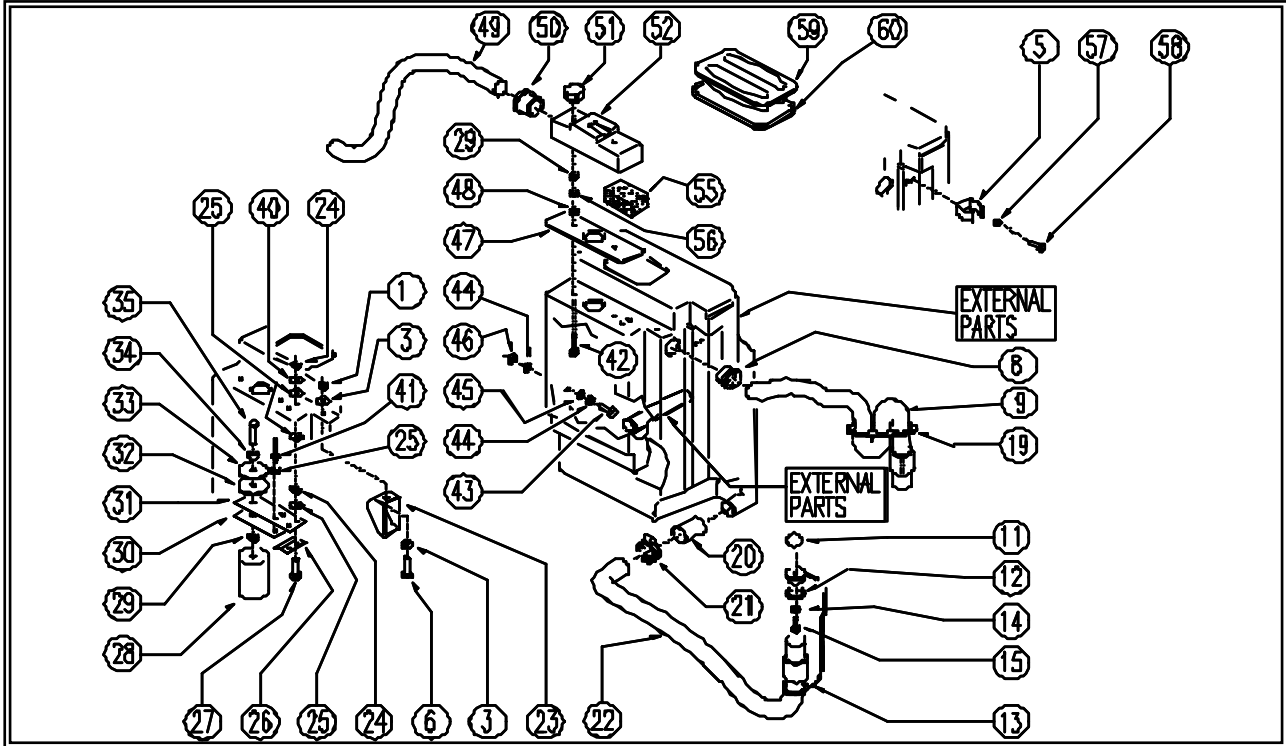

REF	CODE	DESCRIPTION	QTY
<b>450E Automatic Scrubber CODE: pl1198 ac SN from 01A000</b>			
1	SL05016	NUT	1
3	SL06034	WASHER	2
5	SL13014	DUCT LOCK	1
6	SL04152	SCREW	1
8	SL07178	BUSHING / BUSH	1
9	SL19113-2	HOSE	1
11	SL20015	KNOB (o HANDWHEEL)	1
12	SL03315	GASKET	1
13	SL14237	CAP	1
14	SL06022	WASHER	3
15	SL04002	SCREW	1
19	SL03437	PLAQUE	1
20	MP03196	SHEATH	1
21	SL14063	CLAMP	1
22	SL19113-	HOSE	1
23	SL17155-1	BAFFLE PLATE	1
24	SL05044	NUT	4
25	SL06031	WASHER	8
26	SL09675	SMALL BRACKET	1

Next page →



← Back 1 page

REF	CODE	DESCRIPTION	QTY
<b>450E Automatic Scrubber CODE: pl1198 ac SN from 01A000</b>			
27	SL04189	SCREW	2
28	SL18065	FLOAT	1
29	SL05017	NUT	3
30	SL09364	PLATE	1
31	SL03111	RUBBER SHIM	1
32	SL03110	CAP	1
33	SL03235	CAP	1
34	SL06071	WASHER	1
35	SL04087	SCREW	1
40	SL06033	WASHER	2
41	SL14006	RIVET	2
42	SL04140	SCREW	2
43	SL04145	SCREW	1
44	SL06025	WASHER	1
45	SL03122	WASHER	2
46	SL05039	NUT	2
47	SL03113	GASKET	1
48	SL06071	WASHER	2
49	SL19320	HOSE	1
50	SL07044	BUSHING / BUSH	1
51	SL20006	KNOB (o HANDWHEEL)	2
52	SL17141-1	BOX	1
55	SL03109	FILTER	1
56	SL06023	WASHER	1
57	SL06056	WASHER	2
58	SL04213	SCREW	2
59	SL17552	LID	1
60	SL03470	GASKET	1



**450E Automatic Scrubber CODE: pl1214 ab SN from 98E906**

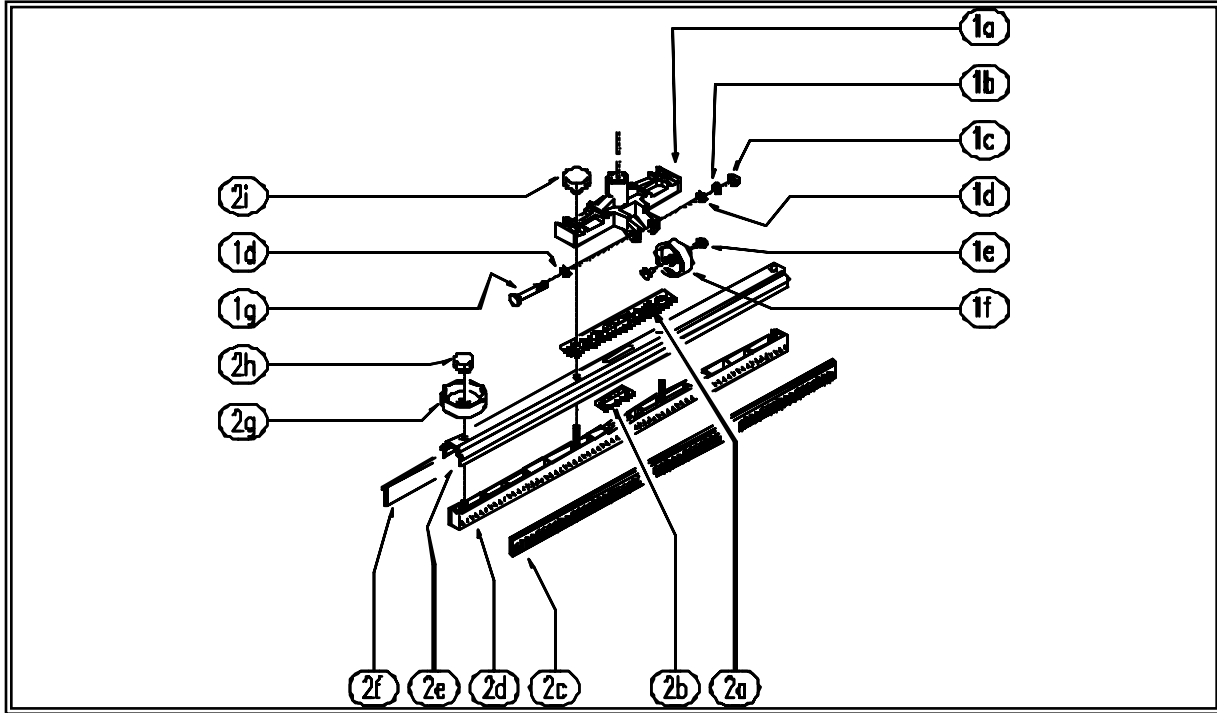

REF	CODE	DESCRIPTION	QTY
	<b>SL03069</b>	<b>SQUEEGEE UNIT</b>	
1a	SL01018	SUCTION OPENING	1
1b	SL06023	WASHER	1
1c	SL05017	NUT	1
1d	SL06022	WASHER	2
1e	SL07077	BUSHING / BUSH	2
1f	SL08015	WHEEL / SMALL WHEEL	1
1g	SL04061	SCREW	1
2a	SL03051	GASKET	1
2b	SL03052	GASKET	1
2c	SL03047	BLADE	1
2d	SL15012	INSERT	1
2e	SL15015	EXTRUSION	1
2f	SL03233	BLADE	1
2g	SL08016	KNOB (o HANDWHEEL)	2
2h	SL20018	KNOB (o HANDWHEEL)	2
2i	SL20002	KNOB (o HANDWHEEL)	2





← Back 1 page

**450E Automatic Scrubber CODE: pl1114C aa SN from 98E905**

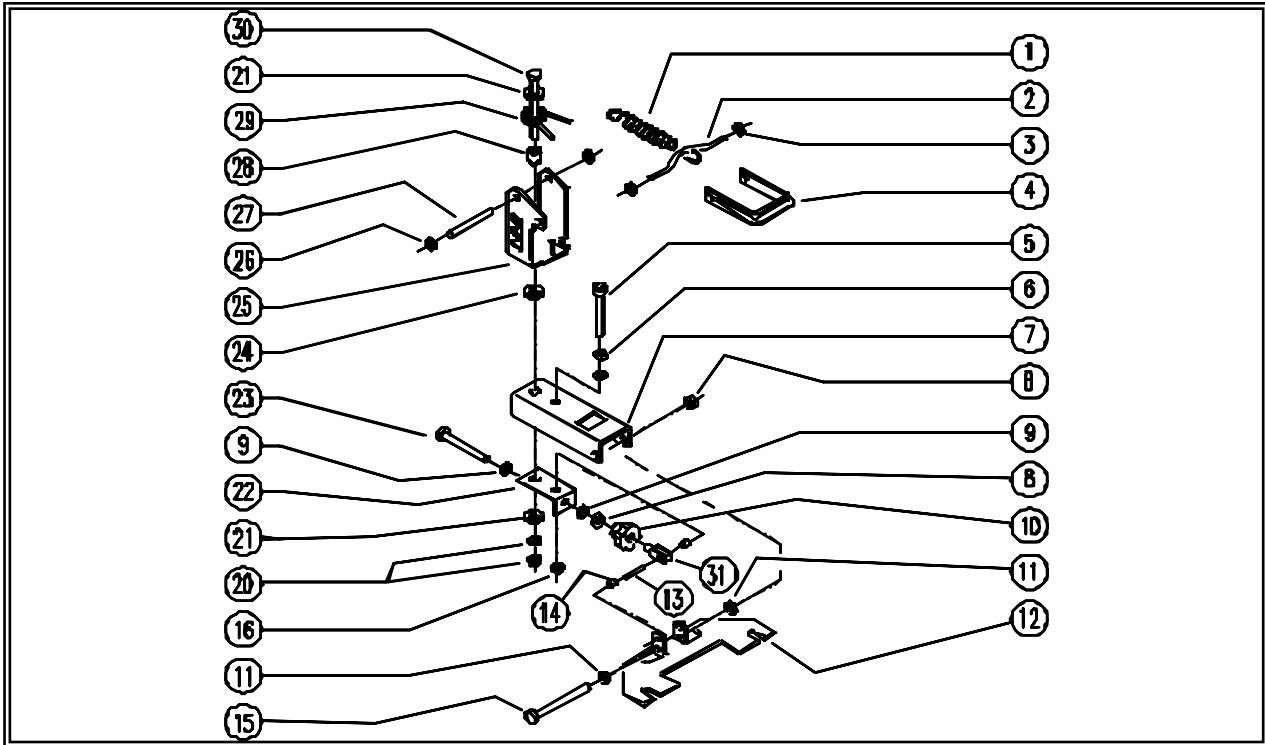

450E Automatic Scrubber CODE: pl1114C aa SN from 98E905

REF	CODE	DESCRIPTION	QTY
1	SL13048	SPRING	1
2	SL09413	HOOKING	1
3	SL06060	RING	2
4	SL17180	HANDLE	1
5	SL04194	SCREW	1
6	SL05017	NUT	2
7	SL09516	ARM	1
8	SL05039	NUT	2
9	SL06041	WASHER	2
10	SL20020	HANDLE	1
11	SL06064	WASHER	2
12	SL09514	PLATE	1
13	SL11050	PIN	1
14	SL07141	SPACER	1
15	SL04229	SCREW	1
16	SL05041	NUT	1
20	SL05048	NUT	2
21	SL06025	WASHER	2
22	SL09513	SUPPORT	1

Next page →



← Back 1 page

450E Automatic Scrubber CODE: pl1114C aa SN from 98E905			
REF	CODE	DESCRIPTION	QTY
23	SL04156	SCREW	1
24	SL07138	WASHER	1
25	SL09515	BRACKET	1
26	SL05041	NUT	2
27	SL11039	PIN	1
28	SL07134	BUSH	1
29	SL13029	SPRING	1
30	SL04164	SCREW	1
31	SL22008	FORK	1



← Back 1 page

**450E Automatic Scrubber CODE: pl1200U aa SN from 98E9**

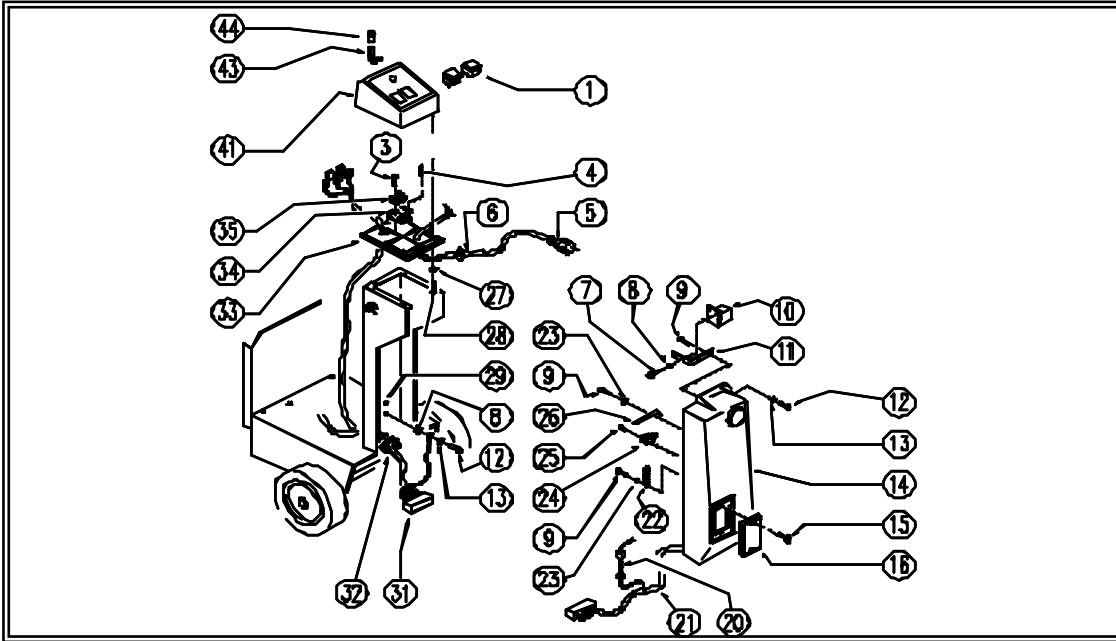

**450E Automatic Scrubber CODE: pl1200U aa SN from 98E905**

REF	CODE	DESCRIPTION	QTY
1	SL23211	SWITCH	2
3	SL04214	SCREW	2
4	SL04187	SCREW	2
5	SL23782	POWER SUPPLY CABLE	1
6	SL23044	FAIRLEAD	1
7	SL04032	SCREW	2
8	SL06033	WASHER	3
9	SL04176	SCREW	4
10	SL23804	RELAIS	1
11	SL09555	BRACKET	1
12	SL04079	SCREW	3
13	SL06019	WASHER	3
14	SL17166	COVER	1
15	SL04027	SCREW	2
16	SL17149-1	LID	1
20	SL23949	FUSE	1
21	SL23421	WIRING	1
22	SL13026	SPRING	1
23	SL06014	WASHER	2
24	SL23120	MICROSWITCH	1
25	SL04178	SCREW	2
26	SL09499	FOIL / LAMINA	1

Next page →



← Back 1 page

450E Automatic Scrubber CODE: pl1200U aa SN from 98E905			
REF	CODE	DESCRIPTION	QTY
27	SL06031	WASHER	4
28	SL04177	SCREW	4
29	SL25185	ADESIVE LABEL	1
31	SL23760-U	WIRING	1
32	SL2311€	FAIRLEAD	1
33	SL1717€	BASE	1
34	SL23080	TERMINAL BOARD HOLDER	1
35	SL2307€	TERMINAL BOARD	1
41	SL1717€	CONTROL PANEL	1
43	SL23014	PILOT LIGHT	1
44	SL23014-1	REFLEX REFLECTOR	1



**450E Automatic Scrubber CODE: pl1169 ab SN from 00A500**

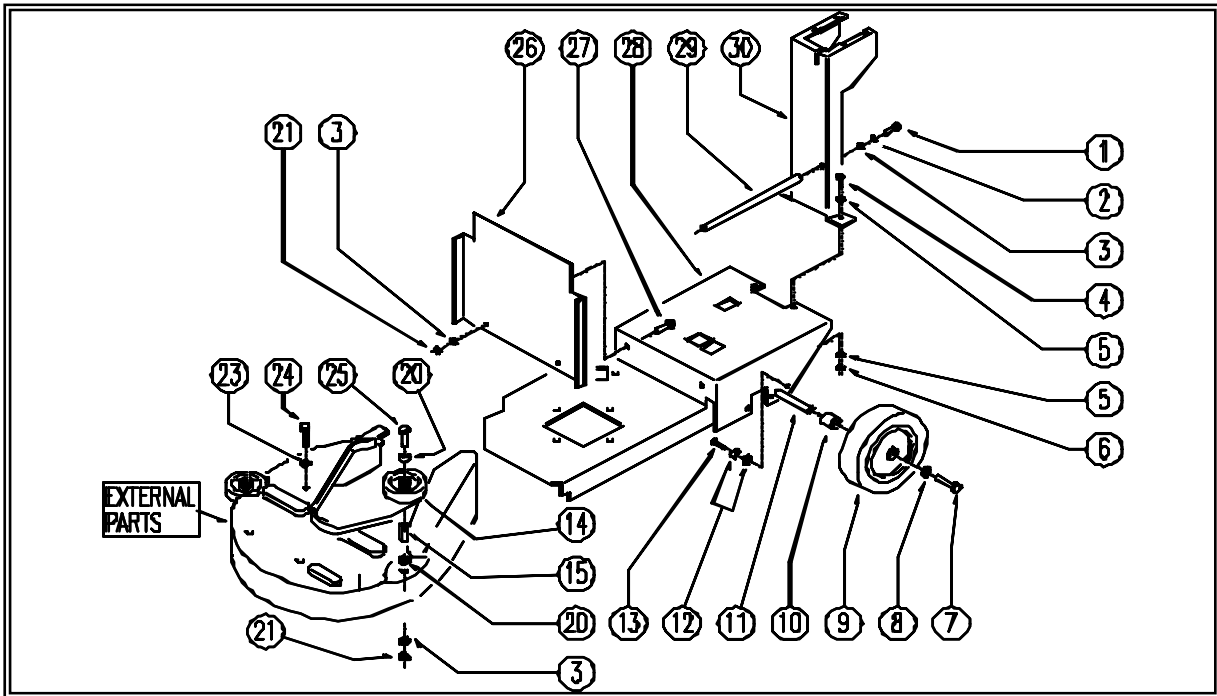

450E Automatic Scrubber CODE: pl1169 ab SN from 00A500

REF	CODE	DESCRIPTION	QTY
1	SL04002	SCREW	1
2	SL06023	WASHER	2
3	SL06022	WASHER	4
4	SL04145	SCREW	2
5	SL06057	WASHER	4
6	SL05039	NUT	2
7	SL04077	SCREW	2
8	SL06025	WASHER	2
9	SL08022	WHEEL / SMALL WHEEL	2
10	SL07193	SPACER	2
11	SL07140	AXLE	1
12	SL06037	WASHER	2
13	SL04079	SCREW	1
14	SL08015	WHEEL / SMALL WHEEL	2
15	SL07165	SPACER	2
20	SL06039	WASHER	4
21	SL05041	NUT	4
23	SL06038	WASHER	2
24	SL04065	SCREW	2
25	SL04133	SCREW	2
26	SL09690	SUPPORT	1
27	SL04216	SCREW	2
28	SL09651	BASEMENT	1
29	SL09349	SPACER	1
30	SL09585	UPRIGHT / PILLAR	1



← Back 1 page

450E Automatic Scrubber CODE: pl1169 ab SN from 00A500

REF	CODE	DESCRIPTION	QTY
-----			



← Back 1 page

**450E Automatic Scrubber CODE: pl1156 ab SN from 99J100**

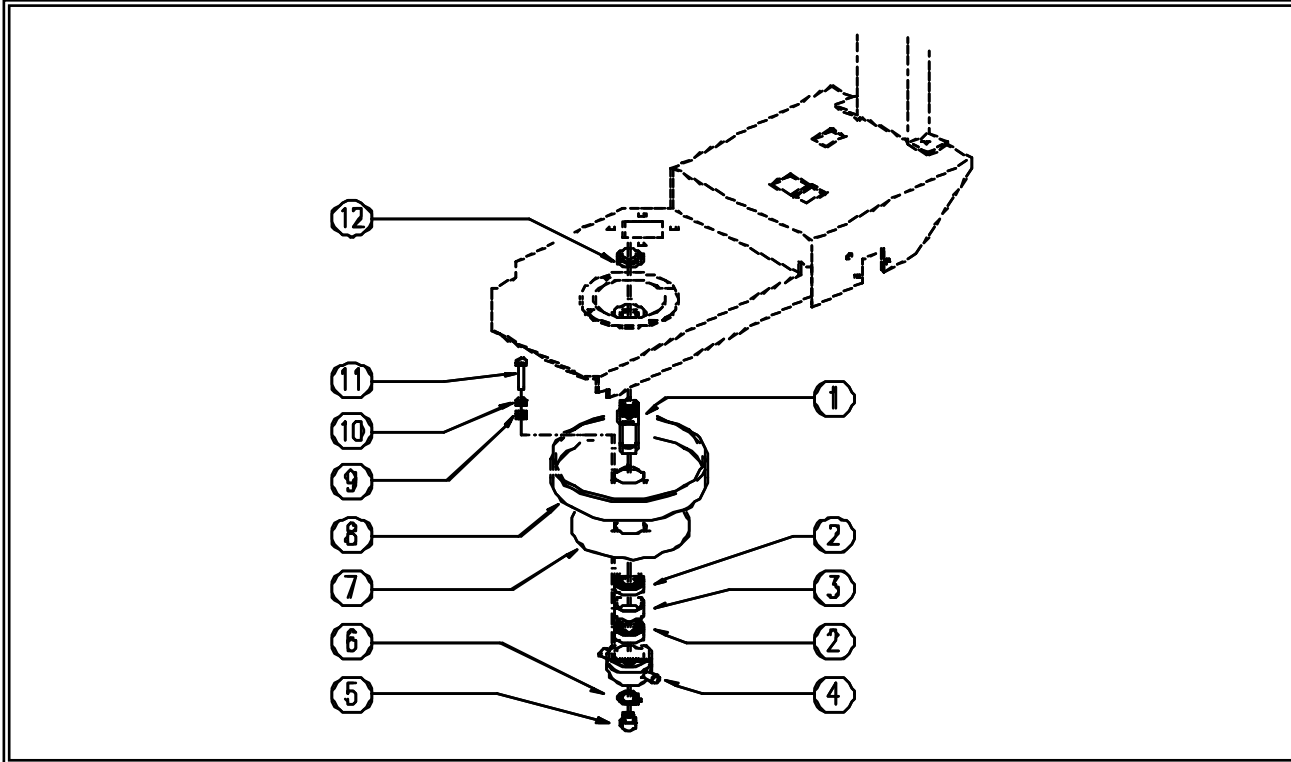

REF	CODE	DESCRIPTION	QTY
1	SL07303	PIN	1
2	SL12025	BEARING	2
3	SL07161	BEARING	1
4	SL01023	CONVEYOR, DRIVER	1
5	SL17163	CAP	1
6	SL11096	SHAFT	1
7	SL03511	DISC	1
8	SL10047	PULLEY	1
9	SL06023	WASHER	3
10	SL06022	WASHER	3
11	SL04135	SCREW	3
12	SL05049	NUT	1



**450E Automatic Scrubber CODE: pl1203UWS aa SN from 01A000**

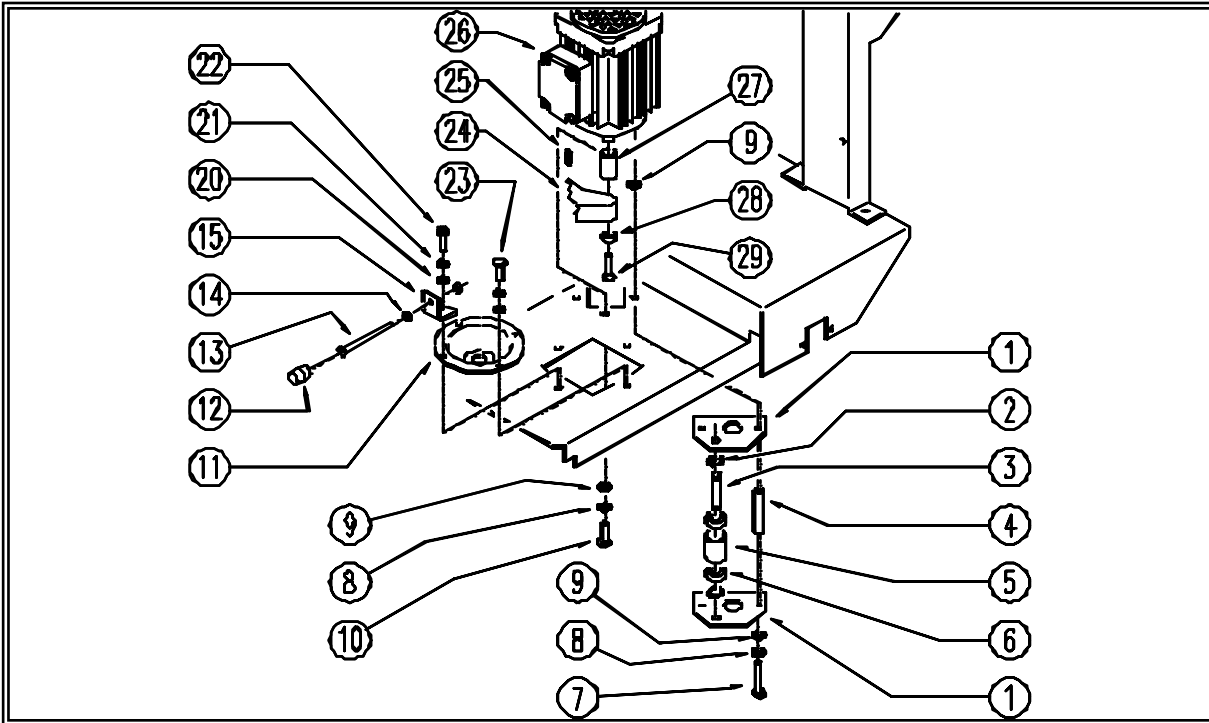

450E Automatic Scrubber CODE: pl1203UWS aa SN from 01A000

REF	CODE	DESCRIPTION	QTY
1	SL09438	PLAQUE	2
2	SL11095	RING	2
3	SL11041	PIN / PLUG	1
4	SL07143	BEARING	2
5	SL10045	PULLEY	1
6	SL12003	BEARING	2
7	SL04140	SCREW	2
8	SL06023	WASHER	3
9	SL06022	WASHER	5
10	SL04002	SCREW	1
11	SL15023	FLANGE	1
12	SL20016	FOOT / PIN	1
13	SL04141	SCREW	1
14	SL05017	NUT	2
15	SL09717	SMALL SQUARE	1
20	SL06041	WASHER	4
21	SL06057	WASHER	4
22	SL04184	SCREW	1
23	SL04134	SCREW	3
24	SL16016	BELT	1
25	SL11002	TANG / TONGUE	1
26	MP02401-U	MOTOR	1
27	SL10046	PULLEY	1
28	SL07166	WASHER	1
29	SL04015	SCREW	1





← Back 1 page

**450E Automatic Scrubber CODE: pl1162 aa SN from 98L000**

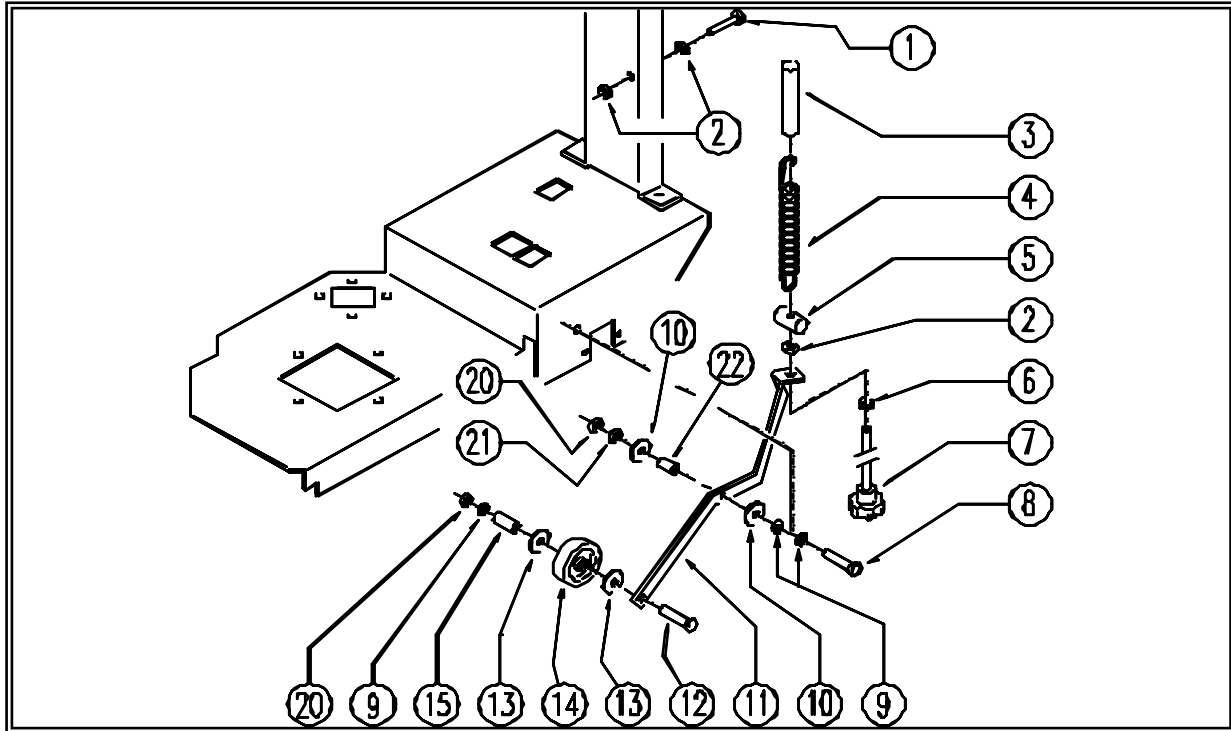

REF	CODE	DESCRIPTION	QTY
1	SL04048	SCREW	1
2	SL05017	NUT	3
3	MP19201	SHEATH	1
4	SL1304E	SPRING	1
5	SL07199	SPRING COUPLING	1
6	SL06039	WASHER	1
7	SL20047	KNOB (o HANDWHEEL)	1
8	SL04127	SCREW	1
9	SL06041	WASHER	3
10	SL06053	WASHER	2
11	SL0958E	LEVER	1
12	SL04156	SCREW	1
13	SL08024-1	WASHER	2
14	SL08024-3	WHEEL / SMALL WHEEL	1
15	SL08024-2	PIN	1
20	SL05039	NUT	2
21	SL05048	NUT	1
22	SL07063	BUSHING / BUSH	1



← Back 1 page

**450E Automatic Scrubber CODE: pl1155L ad SN from 01A000**

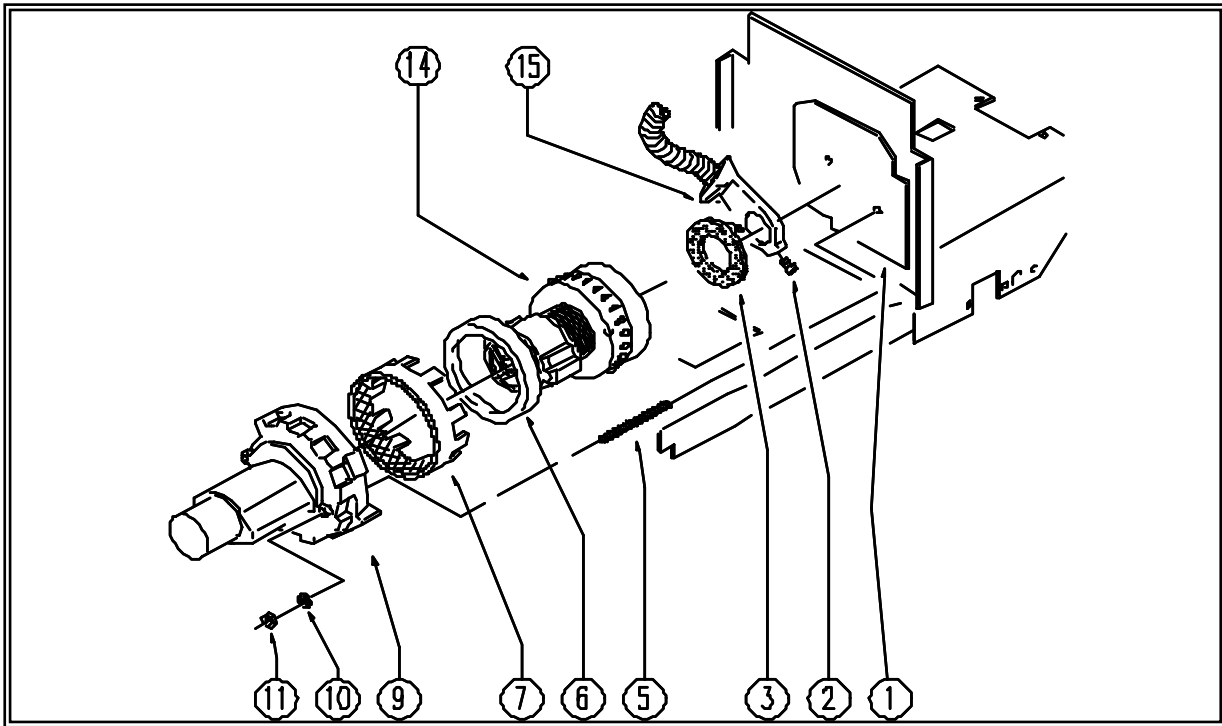

REF	CODE	DESCRIPTION	QTY
1	SL03261	GASKET	1
2	GR1414E	CAP	1
3	SL0303E	GASKET	1
5	SL04281	BAR	2
6	SL0315E	GASKET	1
7	SL0324E	SILENCER	1
9	SL17373	CAP / SHELL	1
10	SL06041	WASHER	2
11	SL0503E	NUT	2
14	MP02307-L	EXHAUSTER / ASPIRATOR	1
15	GR17374	SUCTION CONVEYOR	1



← Back 1 page

**450E Automatic Scrubber CODE: pl1205 ac SN from 01A000**

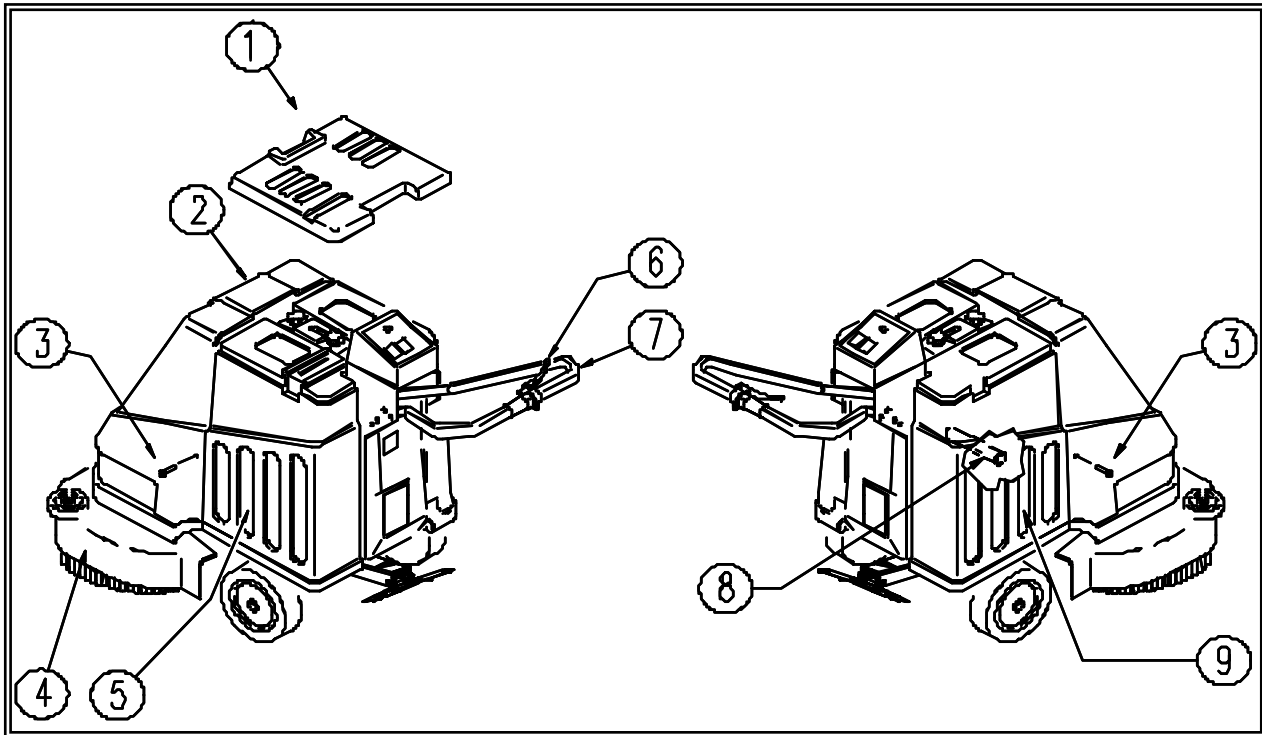

REF	CODE	DESCRIPTION	QTY
1	SL17605NE	LID	1
2	SL17242	HOOD	1
3	SL04027	SCREW	2
4	SL17164-1	BRUSH COVER	1
5	SL17136F	TANK	1
6	SL20019	LEVER	1
7	SL09343	HANDGRIP	1
8	SL07208	CROSS	1
9	SL17230PF	TANK	1



← Back 1 page

**450E Automatic Scrubber CODE: WD27019**

DESCRIPTION:      WIRING DIAGRAM      SCHALTPLAN      SCHEMA ELECTRIQUE      ESQUEMA ELECTRICO

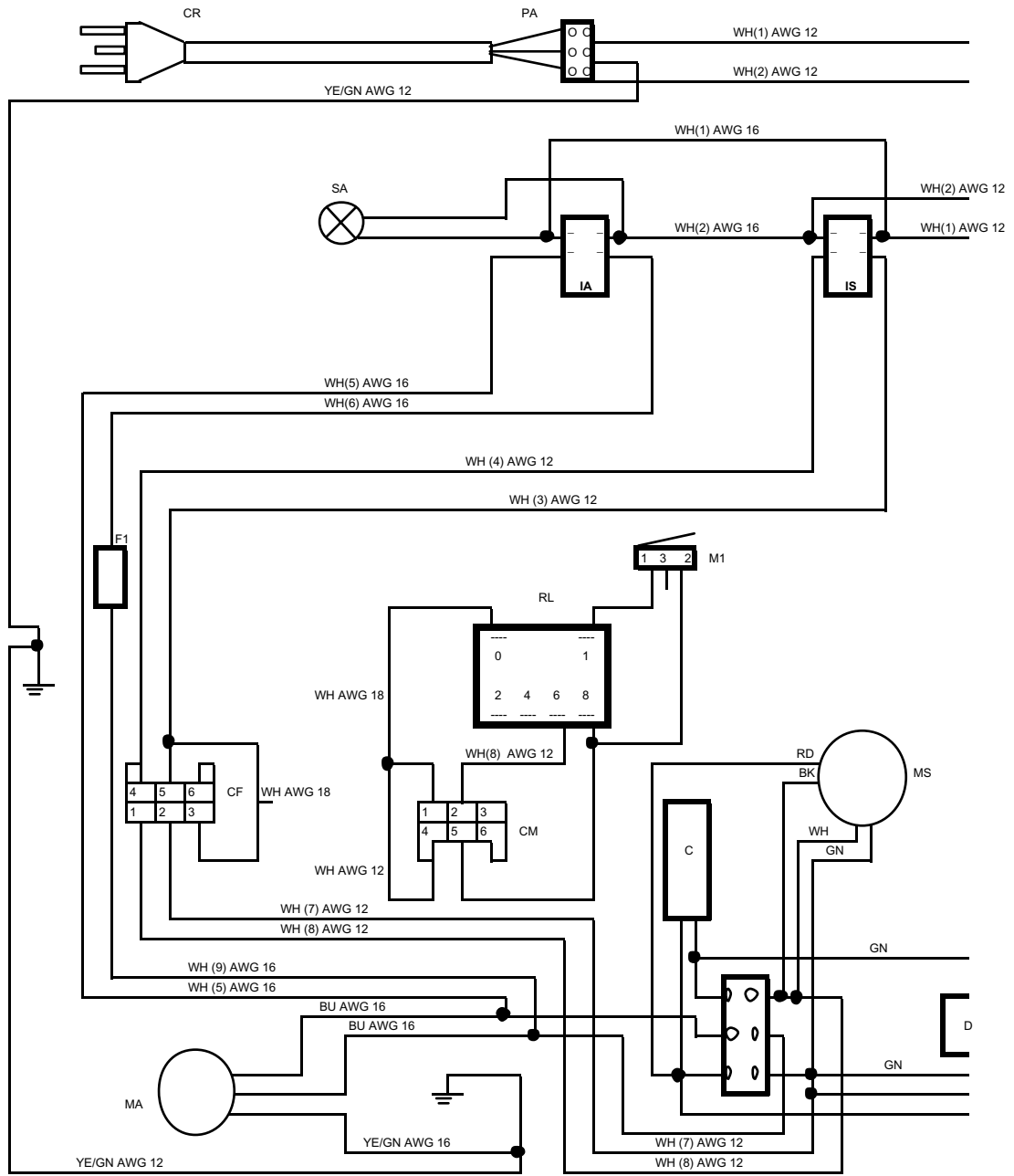

REF CODE	DESCRIPTION
C	CONDENSER
CF	FEMALE CONNECTOR
CM	MALE CONNECTOR
CR	FEEDING CABLE
D	CENTR.CIRCUIT BREAKER
F1	FUSE
IA	VACUUM SWITCH



← Back 1 page

**450E Automatic Scrubber CODE: EPF02215 aa SN from 01A000**

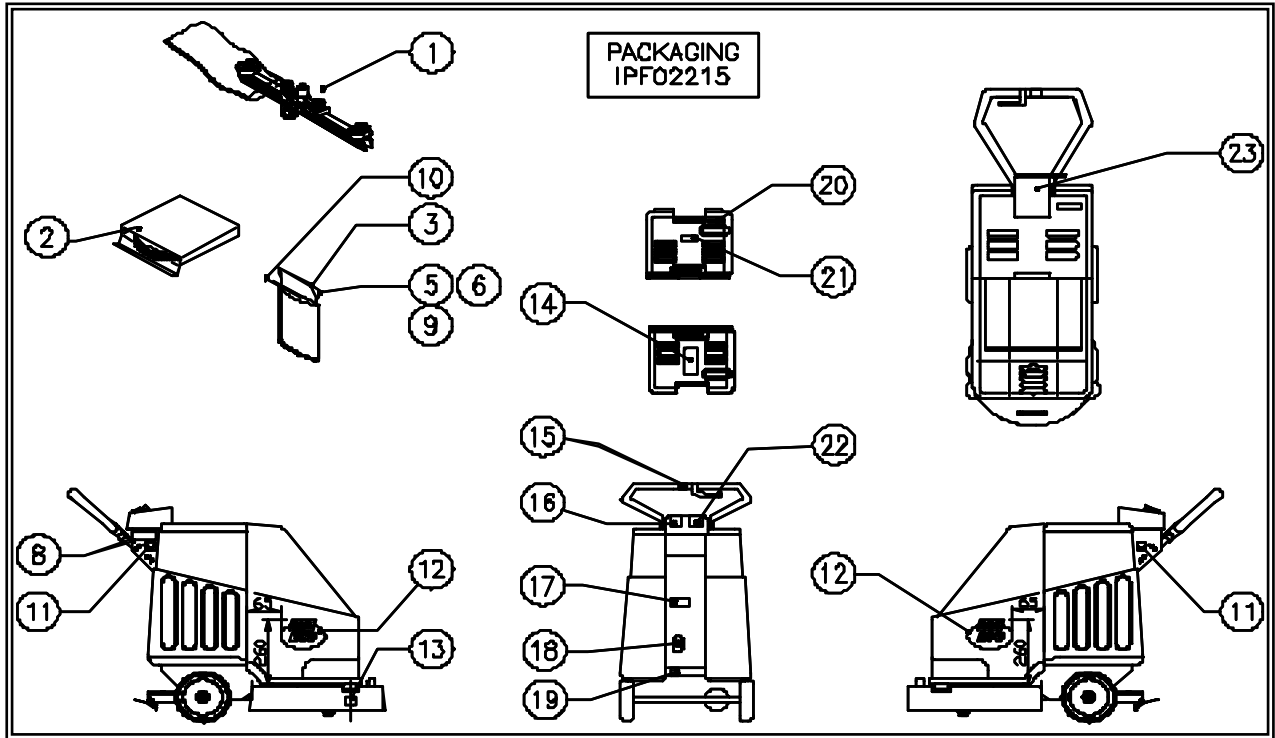

REF	CODE	DESCRIPTION	QTY
1	SL0306€	SQUEEGEE	1
2	AL02251	BRUSH	1
3	SL25189N-1	OPERATOR'S MANUAL	1
5	SL25401-2	LABEL - DOCUMENT	1
6	SL25401-3	LABEL - DOCUMENT	1
8	SL25401-6	LABEL - DOCUMENT	1
9	SL25401-8	LABEL - DOCUMENT	1
10	SL2530€	LABEL	1
11	SL25002	LABEL	2
12	SL2595€	LABEL	2
13	SL25472	LABEL	1
14	SL2505€	LABEL	1
15	SL25006C	LABEL	1
16	SL2517€	LABEL	1
17	SL25154	LABEL	1
18	SL25187	LABEL	1
19	SL2528€	LABEL	1
20	SL25474	LABEL	1
21	SL25473	LABEL	1
22	SL25362	LABEL	1
23	SL25183N	LABEL	1

Next page →



← Back 1 page

IS	BRUSH SWITCH
M1	BRUSH MICROSWITCH
MA	VACUUM MOTOR
MS	BRUSH MOTOR
PA	JUNCTION BOX
RL	RELAY
SA	NET OF CURRENT LIGHT



← Back 1 page

**450E Automatic Scrubber CODE: IPF02215 aa SN from 01A000**

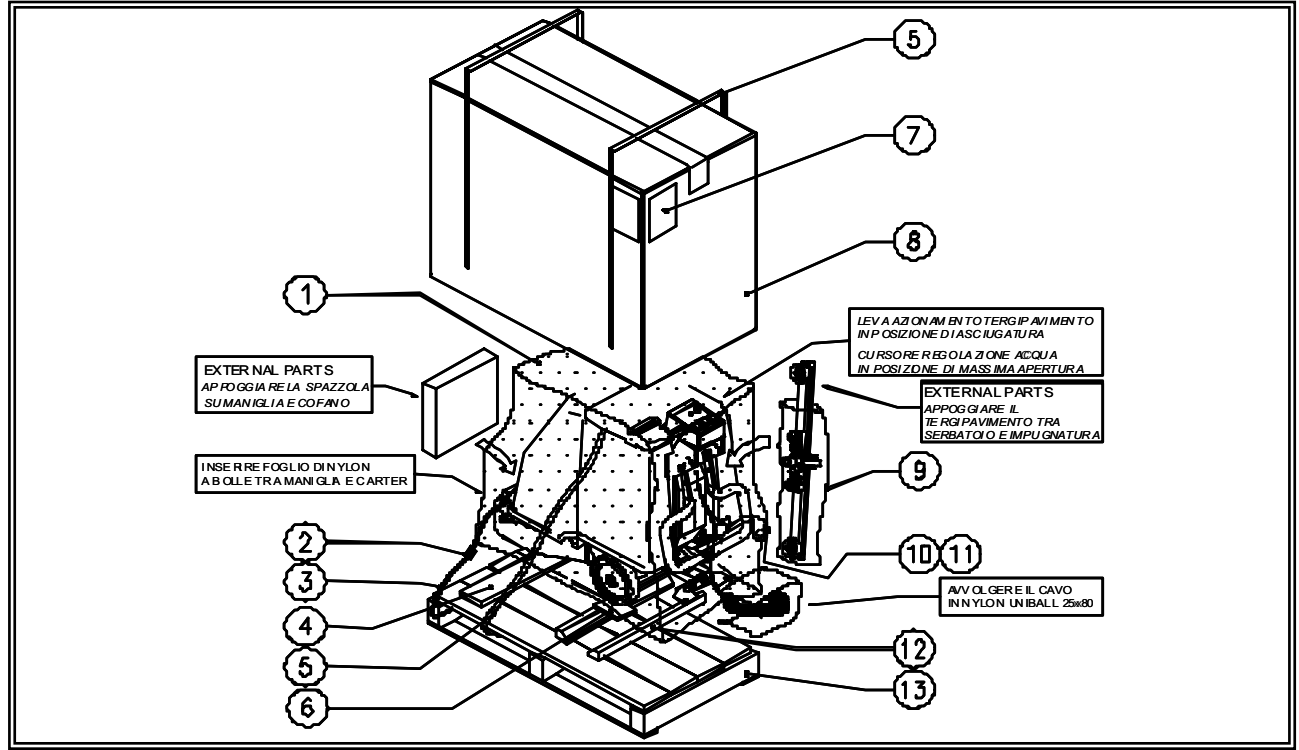

REF	CODE	DESCRIPTION	QTY
1	SL26083	NYLON	1
2	SL26085	BUCKLE	1
3	SL26084	STRAP	1
4	SL26011	LATH / SPLINE	1
5	MP14300	STRAP	2
6	SL26069	CARDBOARD	2
7	SL25401-	LABEL	2
8	SL26009N	CARDBOARD	1
9	SL14302	NYLON	1
10	SL26029	ENVELOPE	1
11	SL20012	KNOB (o HANDWHEEL)	2
12	SL26018	LATH / SPLINE	2



← Back 1 page



### Warranty Policy

#### Limited Warranty

**Eagle Power Products (EPP) warrants new cleaning equipment against defects in material and workmanship under normal use and service to the original purchaser as detailed below.**

#### 10 Years

**Subject to the conditions stated below, EPP warrants polyethylene tanks and housings to be free from defects in materials and workmanship for a period of ten years.**

#### 3 Years

**Subject to the conditions stated below, EPP warrants all automatic scrubber components to be free from defects in materials and workmanship for a 3-year period. Parts replaced or repaired are warranted for the remainder of the original warranty period.**

#### 1 Year

**Subject to the conditions stated below, EPP warrants all other cleaning equipment components to be free from defects in materials and workmanship for a 1-year period. Parts replaced or repaired are warranted for the remainder of the original warranty period. Batteries are prorated for one year.**

**EPP will furnish and charge for replacement parts, including transportation, to the original owner through an EPP authorized service center. If the part is returned within 30 days and is found defective, the owner will be credited for the cost of the replacement part including shipping and handling.**

Labor charges are covered for one year from the date of purchase if provided by an authorized EPP service center. Travel is covered for 90 days for battery operated equipment only.

Wear items exempt from warranty include belts, carbon brushes, power cords, wheels, pad drivers, clutch plates, brushes, pads, handle grips, filters, screens, throttle cables, and squeegees.

This warranty shall not apply to failures caused by misuse or abuse, improper maintenance as stated in the operation manuals, use of unauthorized repair parts, repairs by other than an EPP authorized service center, and damage in transit.

EPP disclaims and denies any liability for any direct, indirect, special incidental or consequential damage which may be suffered as a result of sale, delivery, servicing, use, loss of any product, downtime, labor, freight, or other charges not expressly included herein.

Date Purchased: \_\_\_\_\_

Serial Number: \_\_\_\_\_

Serial Number: \_\_\_\_\_

Please be sure to record this information. This information will be necessary for future warranty claims.



1174 Northland Drive Mendota Heights, MN 55120  
651.686.5399 Fax 651.686.5695  
www.eaglepower.com

*Eagle Power Products Sales and Service Provided by:*