

AquaPro™ C

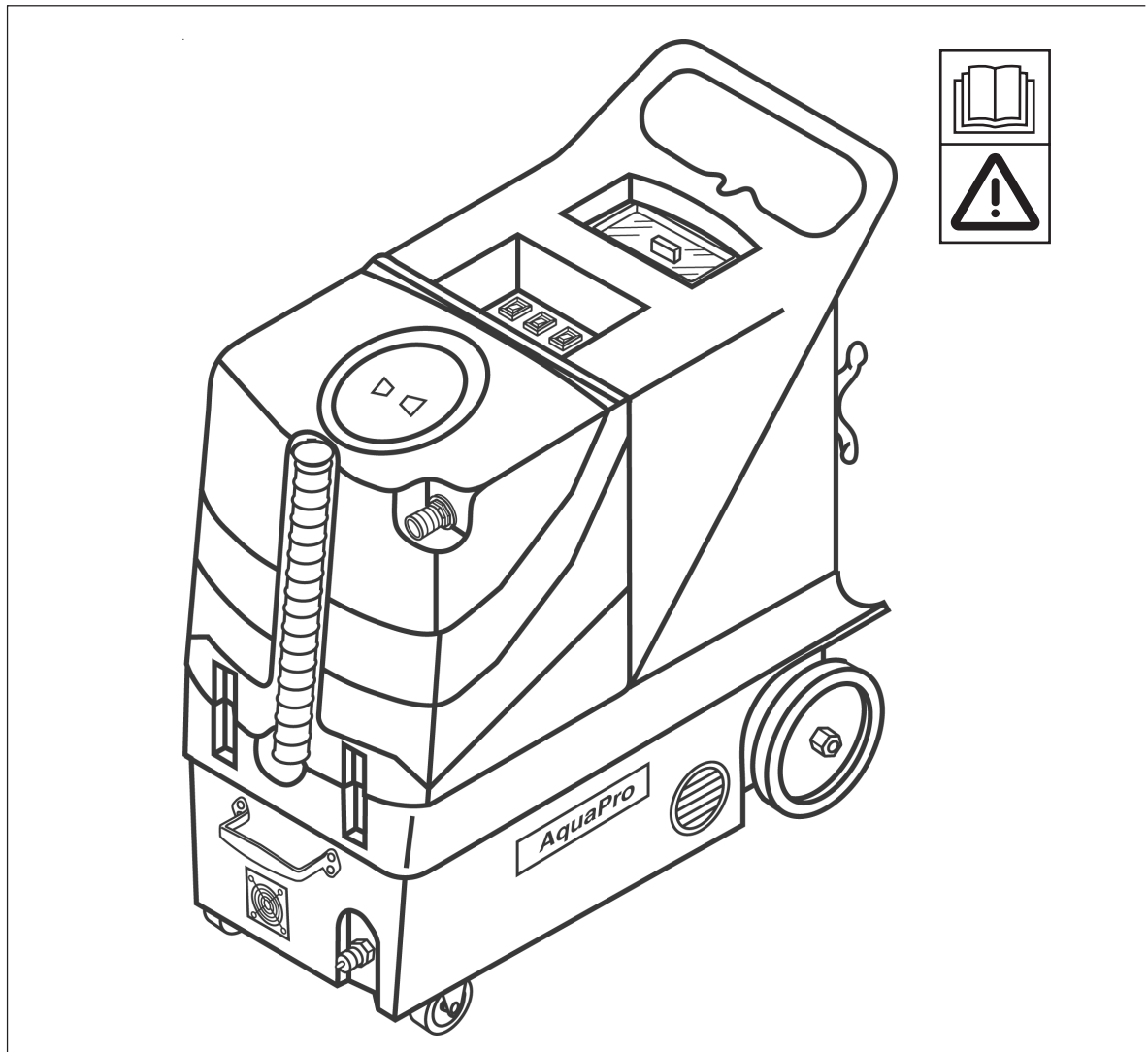

Instructions for use and parts list

Advance MODEL 56102800



Advance
by Nilfisk-Advance

06/03 revised 11/03 Form Number 56041561

INTRODUCTION

This manual will help you get the most from your **Advance AquaPro™ C**. Read thoroughly before operating the machine.

NOTE: Bold numbers in parenthesis indicate an item illustrated on page 7.

This product is intended for commercial use only.

PARTS AND SERVICE

Repairs, when required, should be performed by your authorized Advance Service Center, who employs factory-trained service personnel, and maintains an inventory of Advance original replacement parts and accessories.

Call the Advance DEALER named below for parts or service. Please specify the Model and Serial Number when discussing your machine.

(Dealer, affix service sticker here)

NAME PLATE

The Model and Serial Number of your machine are shown on the nameplate in the machine. This information is needed when ordering repair parts for the machine. Use the space below to note the Model and Serial Number of your machine for future reference.

MODEL : _____

SERIAL NUMBER : _____

UNCRATING

When the machine is delivered, carefully inspect the shipping carton and the machine for damage. If damage is evident, save the shipping carton so that it can be inspected. Contact Advance Customer Service Department immediately to file a freight damage claim.

DO NOT OPERATE THE MACHINE UNTIL YOU HAVE READ THIS SECTION. IMPROPER USE WILL VOID THE WARRANTY.

- Always use a defoamer when foaming occurs to prevent vacuum motor damage.
- Never use water above 140° F (60°C).
- Do not store outdoors. Avoid extremes in temperature.
- Do not let the pump run dry. Turn the pump off and refill that tank when cleaning solution gets low.
- Use approved chemicals only. All chemicals should be mixed thoroughly. Liquid chemicals are recommended to prevent powder buildups. A pH between 6 and 9 is recommended. The use of high alkaline detergents or strong acids will accelerate the wear of the pump and seals, and will void the warranty.
- All extension cords must have a rating of at least 12/3 (#12 cord). Extension cords should be no longer than 50 feet. Replace the plug immediately if the ground prong becomes damaged or is broken off.

IMPORTANT SAFETY INSTRUCTIONS

This machine is only suitable for commercial use, for example in hotels, schools, hospitals, factories, shops and offices other than normal residential housekeeping purposes.

When using an electrical appliance, basic precautions should always be followed, including the following:

Read all instructions before using this appliance.

WARNING!

To reduce the risk of fire, electric shock, or injury:

- Do not leave the appliance when it is plugged in. Unplug the unit from the outlet when not in use and before servicing.
- To avoid electric shock, do not expose to rain. Store indoors.
- Do not allow to be used as a toy. Close attention is necessary when used near children.
- Use only as described in this manual. Use only the manufacturer's recommended attachments.
- Do not use with damaged cord or plug. If the appliance is not working as it should be, has been dropped, damaged, left outdoors or dropped into water, return it to a service center.
- Do not pull or carry by the cord, use the cord as a handle, close a door on the cord, or pull the cord around sharp edges or corners. Do not run the appliance over the cord. Keep the cord away from heated surfaces.
- Do not unplug by pulling on the cord. To unplug, grasp the plug, not the cord.
- Do not handle the plug, cord or appliance with wet hands.
- Do not put any object into openings. Do not use with any opening blocked; keep free of dust, lint, hair, and anything that may reduce air flow.
- Keep loose clothing, hair, fingers, and all parts of body away from openings and moving parts.
- Do not pick up anything that is burning or smoking, such as cigarettes, matches, or hot ashes, or any health endangering dusts.
- Turn off all controls before unplugging.
- Use extra care when cleaning on stairs.
- Do not use to pick up flammable or combustible liquids such as gasoline or use in areas where they may be present.
- Connect to a properly grounded outlet only. See Grounding Instructions.
- Liquid ejected at the spray nozzle could be dangerous as a result of its temperature, pressure or chemical content.

SAVE THESE INSTRUCTIONS

CONSIGNES DE SECURITE IMPORTANTES

Cette machine ne convient qu'à un usage industriel, par exemple dans des hôtels, écoles, hôpitaux, usines, boutiques et bureaux et autres à l'exclusion de tout usage de maintenance résidentielle normale.

L'utilisation d'un appareil électrique demande certaines précautions:

LIRE TOUTES LES INSTRUCTIONS AVANT DE FAIRE FONCTIONNER (CET APPAREIL)

AVERTISSEMENT!

Pour réduire les risques d'incendie, de choc électrique ou de blessure:

- Ne pas laisser l'appareil sans surveillance lorsqu'il est branché. Débrancher lorsque l'appareil n'est pas utilisé et avant l'entretien.
- Pour réduire les risques de choc électrique, utiliser à l'intérieur seulement.
- Ne pas permettre aux enfants de jouer avec l'appareil. Une attention particulière est nécessaire lorsque l'appareil est utilisé par des enfants ou à proximité de ces derniers.
- N'utiliser que conformément à cette notice avec les accessoires recommandés par le fabricant.
- Ne pas utiliser si le cordon ou la fiche est endommagé. Retourner l'appareil à un atelier de réparation s'il ne fonctionne pas bien, s'il est tombé ou s'il a été endommagé, oublié à l'extérieur ou immergé.
- Ne pas tirer soulever ou traîner l'appareil par le cordon. Ne pas utiliser le cordon comme une poignée, le coincer dans l'embrasure d'une porte ou l'appuyer contre des arêtes vives ou des coins. Ne pas faire rouler l'appareil sur le cordon. Garder le cordon à l'écart des surfaces chaudes.
- Ne pas débrancher en tirant sur le cordon. Tirer plutôt la fiche.
- Ne pas toucher la fiche ou l'appareil lorsque vos mains sont humides.
- N'insérer aucun objet dans les ouvertures. Ne pas utiliser l'appareil lorsqu'une ouverture est bloquée. S'assurer que de la poussière, de la peluche, des cheveux ou d'autres matières ne réduisent pas le débit d'air.
- Maintenir les cheveux, les vêtements amples, les doigts et toutes les parties du corps à l'écart des ouvertures et des pièces mobiles.
- Ne pas aspirer de matières en combustion ou qui dégagent de la fumée, comme des cigarettes, des allumettes ou des cendres chaudes.
- Mettre toutes les commandes à la position ARRÊT avant de débrancher l'appareil.
- User de prudence lors du nettoyage des escaliers.
- Ne pas aspirer des liquides inflammables or combustibles, comme de l'essence, et ne pas faire fonctionner dans des endroits où peuvent se trouver de tels liquides.
- Ne brancher qu'à une prise de courant avec mise à la terre. Voir les instructions visant la mise à la terre.
- Le liquide qui sort de l'embout de vaporisation peut s'avérer dangereux en raison de sa température, de sa pression ou du produit chimique qu'il contient.

CONSERVER CES INSTRUCTIONS

120VAC GROUNDING INSTRUCTIONS

This appliance must be grounded. If it should electrically malfunction, grounding provides a path of least resistance for electric current to reduce the risk of electric shock. This appliance is equipped with a cord having an equipment-grounding conductor and grounding plug. The plug must be plugged into an appropriate outlet that is properly installed and grounded in accordance with all local codes and ordinances.

DANGER!

Improper connection of the equipment-grounding conductor can result in a risk of electric shock. Check with a qualified electrician or service person if you are in doubt as to whether the outlet is properly grounded. Do not modify the plug provided with the appliance. If it will not fit the outlet, have a proper outlet installed by a qualified electrician.

This appliance is for use on a nominal 120-volt circuit, and has a grounding plug that looks like the plug illustrated in Figure 1 below. A temporary adapter illustrated in Figures 2 and 3 may be used to connect this plug to a 2-pole receptacle as shown in Figure 2 if a properly grounded outlet is not available. The temporary adapter should be used only until a properly grounded outlet (Figure 1) can be installed by a qualified electrician. The green-colored rigid ear, tab, or the like extending from the adapter must be connected to a permanent ground such as a properly grounded outlet box cover. Whenever the adapter is used, it must be held in place by a metal screw. Grounding adapters are not approved for use in Canada.

Replace the plug if the grounding pin is damaged or broken.

The Green (or Green/Yellow) wire in the cord is the grounding wire. When replacing a plug, this wire must be attached to the grounding pin only.

Extension cords connected to this machine should be 12 gauge, three-wire cords with three-prong plugs and outlets. DO NOT use extension cords more than 50 feet (15 m) long.

PLEASE NOTE: FOR NORTH AMERICA ONLY

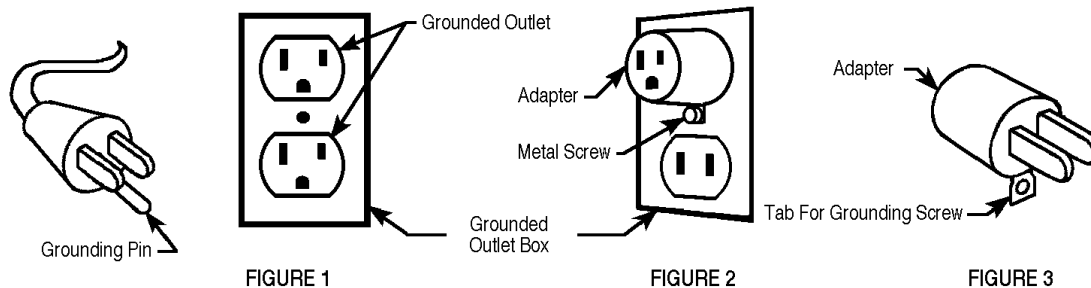

INSTRUCTIONS VISANT LA MISE À LA TERRE (120VAC)

Cet appareil doit être mis à la terre. En cas de défaillance ou de panne éventuelles, la mise à la terre fournit au courant un chemin de moindre résistance qui réduit le risque de choc électrique. Cet appareil est pourvu d'un cordon muni d'un conducteur de terre et d'une fiche avec broche de terre. La fiche doit être branchée dans une prise appropriée correctement installée et mise à la terre conformément aux règlements et ordonnances municipaux.

⚠ AVERTISSEMENT !

Un conducteur de terre mal raccordé peut entraîner un risque de choc électrique. Consulter un électricien ou un technicien d'entretien qualifié si vous n'êtes pas certain que la prise est correctement mise à la terre. Ne pas modifier la fiche fournie avec l'appareil - si elle ne peut être insérée dans la prise, faire installer une prise adéquate par un électricien qualifié.

Cet appareil est destiné à un circuit de 120 V et est muni d'une fiche de terre semblable à celle illustrée par le croquis 1. Un adaptateur temporaire semblable à celui illustré par le croquis 2 et C peut être utilisé pour brancher cette fiche à une prise bipolaire comme l'illustre le croquis 2 si une prise avec mise à la terre n'est pas disponible. L'adaptateur temporaire devrait être utilisé seulement jusqu'à ce qu'une prise avec mise à la terre soit installée par un électricien qualifié. L'oreille rigide ou le crochet ou autre dispositif semblable, de couleur verte, prolongeant l'adaptateur doit être raccordé à un élément correctement mis à la terre comme le couvercle d'une boîte de sortie mise à la terre. L'adaptateur doit être fixé par une vis métallique. Note: Au Canada, l'utilisation d'un adaptateur temporaire n'est pas autorisée par le Code canadien de l'électricité.

Remplacez la prise si la prise de terre est abîmée ou cassée.

Le fil Vert (ou Vert/Jaune) dans la gaine est le fil de terre. Lors du remplacement d'une prise, ce fil doit être raccordé à la prise de terre uniquement.

Les ralonges connectées à cette machine doivent avoir 12 mesures, trois ganses de fil ayant trois fiches masculines féminines tree-prong plugs and outlets. N'UTILISEZ PAS de ralonge de plus de 15 m (50 pieds) de long.

VEUILLEZ NOTER: CES INSTRUCTIONS CONCERNENT UNIQUEMENT L'AMÉRIQUE DU NORD

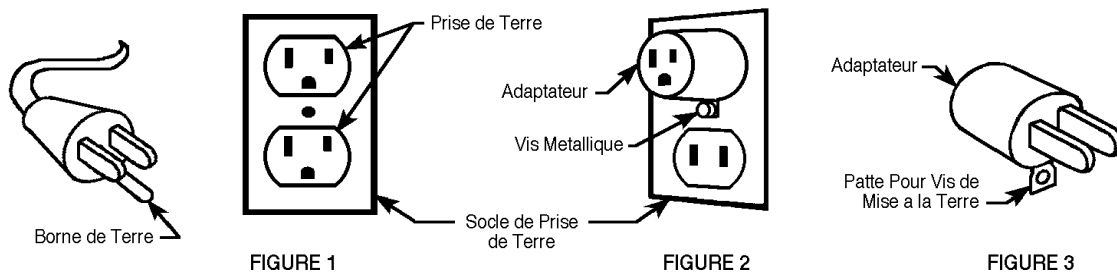

KNOW YOUR MACHINE

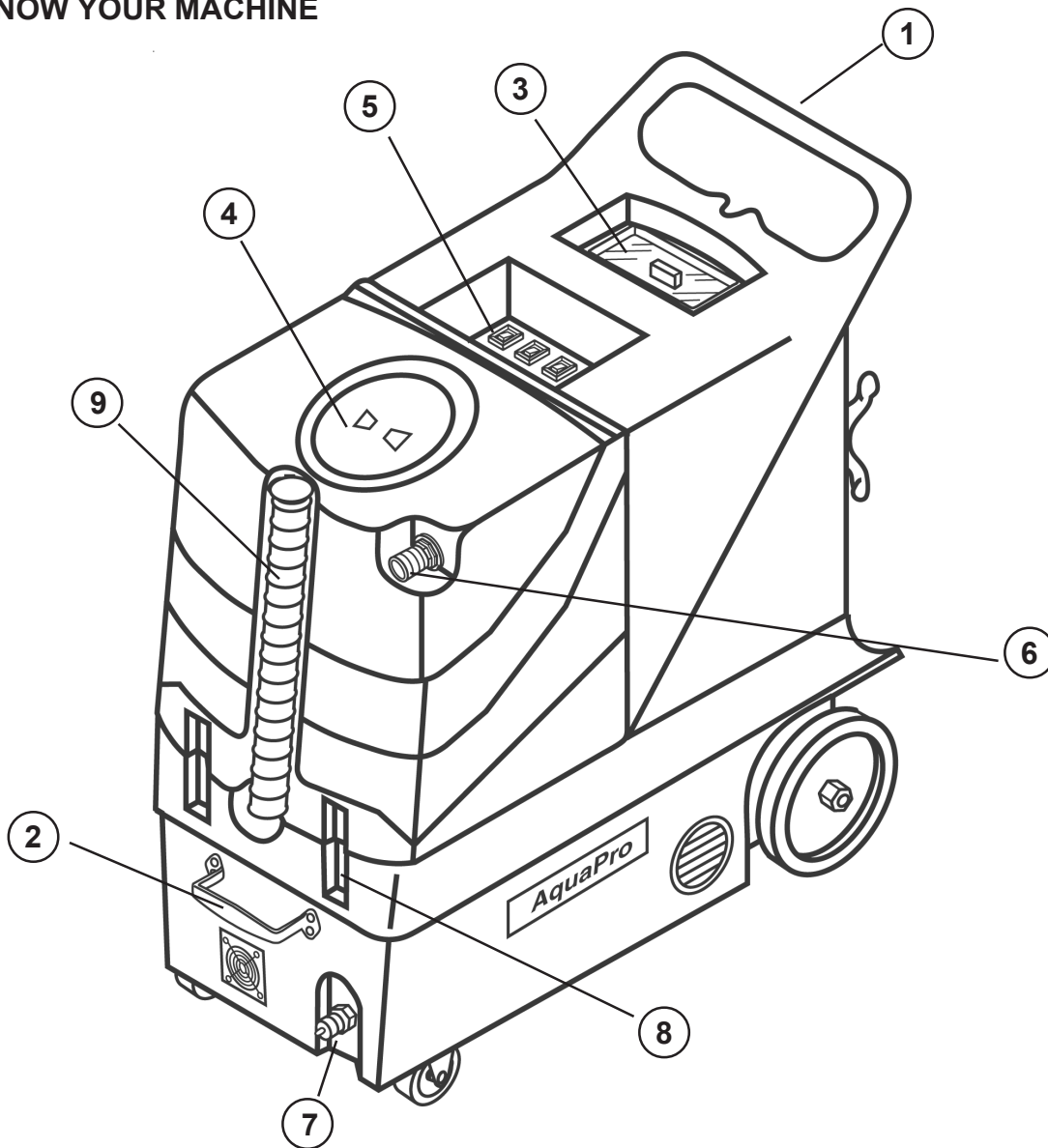

KNOW YOUR MACHINE DESCRIPTIONS

Operator Handle (1) - Operator holds this to move the machine from one location to another.

Lift Handle (2) - Operator grasps this handle when lifting the machine.

Solution Tank Lid (3) - Fill Solution Tank here with warm water and chemicals.

Recovery Tank Lid (4) - The Recovery Tank can be flushed out by running clean water into this opening with the Recovery Tank Drain Hose open. The vacuum float Shut-OFF can also be accessed through this opening for maintenance.

Switch Plate (5) - The switches that operate the motors are located here

Vacuum Hose Connector (6) - This is where the vacuum hose attaches to the machine.

Solution Hose Connector (7) - This is where the solution hose attaches to the machine.

Latches (8) - These latches can be opened if the base compartment needs to be accessed. The latches are normally closed to keep the machine sections held together tightly.

Drain Hose (9) - This hose is used to empty the recovery tank of dirty water.

SWITCH PLATE DESCRIPTIONS

Vacuum Switches (1 and 2) - These switches each turn one vacuum on and off. The switches will light when ON. When using just one vacuum, as when cleaning delicate fabric, use vacuum 1.

Pump Switch (3) - This switch turns the pump on and off. The switch will light when ON.

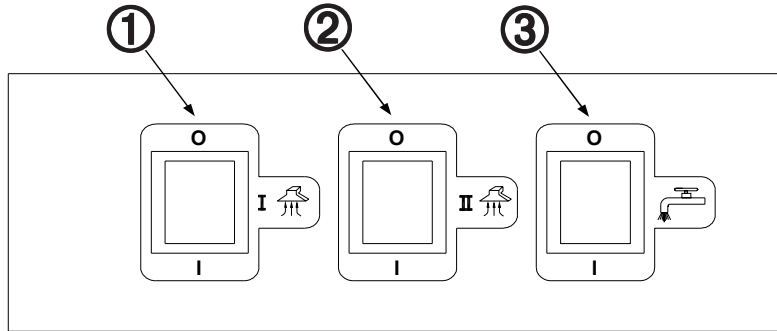

WIRING DIAGRAM

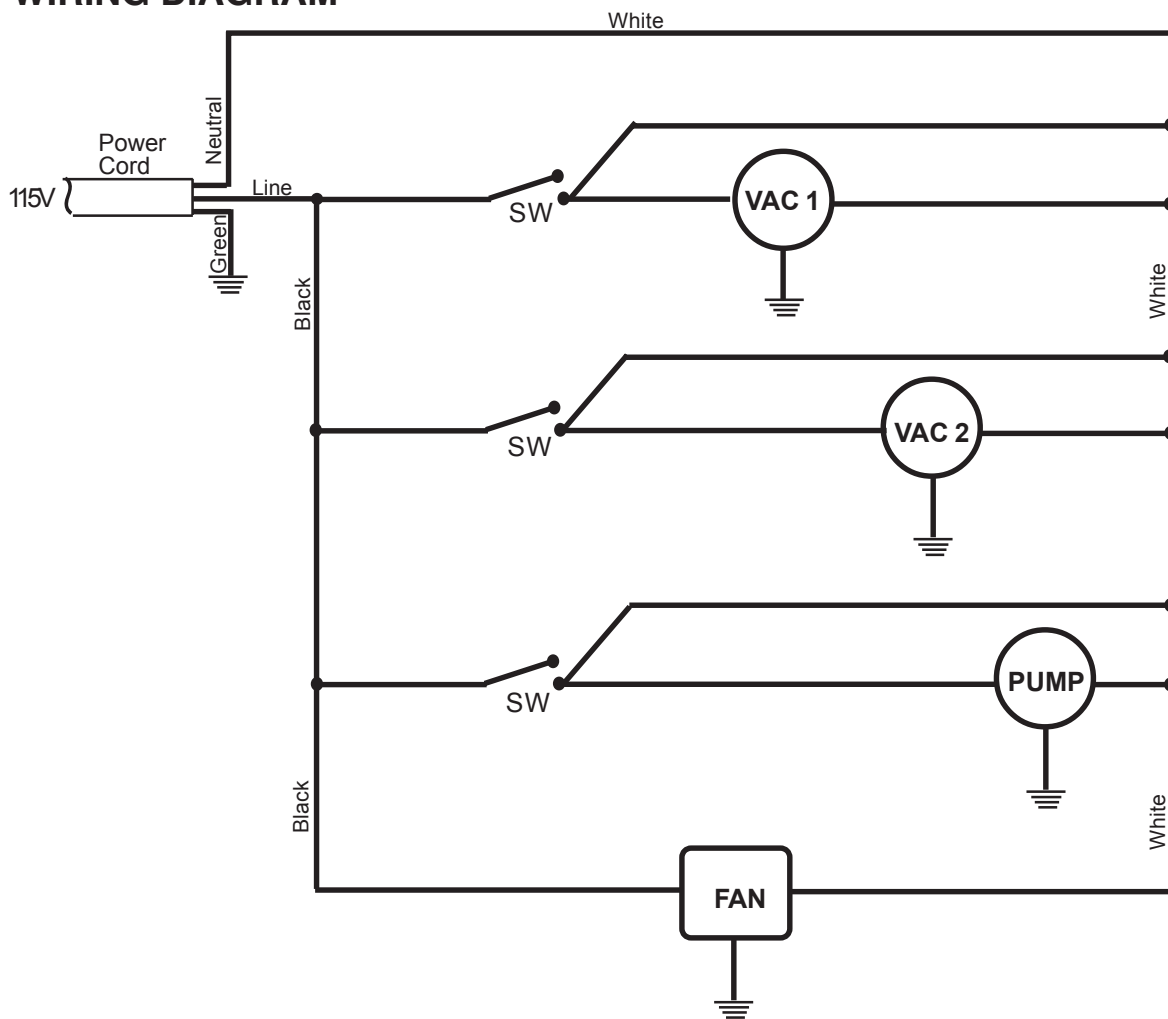

OPERATION

- 1 Inspect the machine, hoses, and cleaning tool(s) for cleanliness and completeness.
- 2 Fill the Solution Tank with warm water. Using warm water may be a benefit in cleaning effectiveness, but do not use hot water (above 140°F / 60°C) in the tank. Add liquid cleaning solution with a pH of between 6 and 9.
- 3 Plug in the power cord.
- 4 Attach the spray hose to the solution quick disconnect and the vacuum hose to the hose barb on the recovery tank. Attach the other ends of the hoses to the cleaning tool.
- 5 Turn the pump on. Turn the vacuum(s) on. NOTE: the pump has a built in pressure switch; the pump only runs when you are spraying.
- 6 Begin cleaning using the correct hoses and tool.
- 7 Use defoamer in the recovery tank if foaming occurs.
- 8 Monitor the water level in the solution tank. Do not let the pump run dry.
- 9 When the solution tank gets low on fluid, turn the pump off, fill the Solution Tank, empty and clean the Recovery Tank.
- 10 When finished with the job, remove any unused solution from the solution tank, and run a few gallons of clean water through the system.

BALL FLOAT VACUUM SHUT-OFF

Prior to using the machine, always check that the float filter is clean and the ball can travel freely. When the recovery tank is full, the ball float will rise and will shut off the vacuum flow to prevent any more water from entering the tank. Turn off the vacuum, and empty the recovery tank. NOTE: if foam is present or if the ball float is prevented from rising, the float will not be able to stop the air flow, and the tank might over fill.

CAUTION!

To avoid vacuum motor damage, always make sure the float filter is clean and the ball can travel freely prior to using the machine. And always use a defoamer when foaming occurs.

USE AND MAINTENANCE

- 1 Use only liquid chemicals with a pH between 6 and 9 at the recommended mix ratios. Improper chemicals, or improperly mixed chemicals, can cause possible damage to the pump, seals, and other components.
- 2 Turn the pump "off" when the solution tank is low on fluid. Do not let the pump run dry.
- 3 Regularly clean any mineral or chemical deposits in the heat exchanger, lines and pump with a mild acid descaler. Rinse the descaler out of the machine with a few gallons of clear water.
- 4 Prior to each job, inspect, and clean if needed, the solution filter, the recovery tank float filter, and the drain hose.
- 5 Make sure the airways are not blocked before each use.
- 6 Inspect the carbon brushes on the vacuum motors once a year. Replace if worn down.
- 7 Clean the recovery tank daily. Clean the body and wheels as needed.
- 8 Keep the machine from extremes in temperatures.

MAINTENANCE SCHEDULE	Daily	Monthly	Yearly
FLUSH LINES & PUMP	X		
CLEAN VACUUM FLOAT FILTER	X		
CLEAN SOLUTION FILTER	X		
CHECK INLET AIRWAYS	X		
DESCALE MACHINE		X	
CHECK VACUUM MOTOR BRUSHES			X

NOTES:

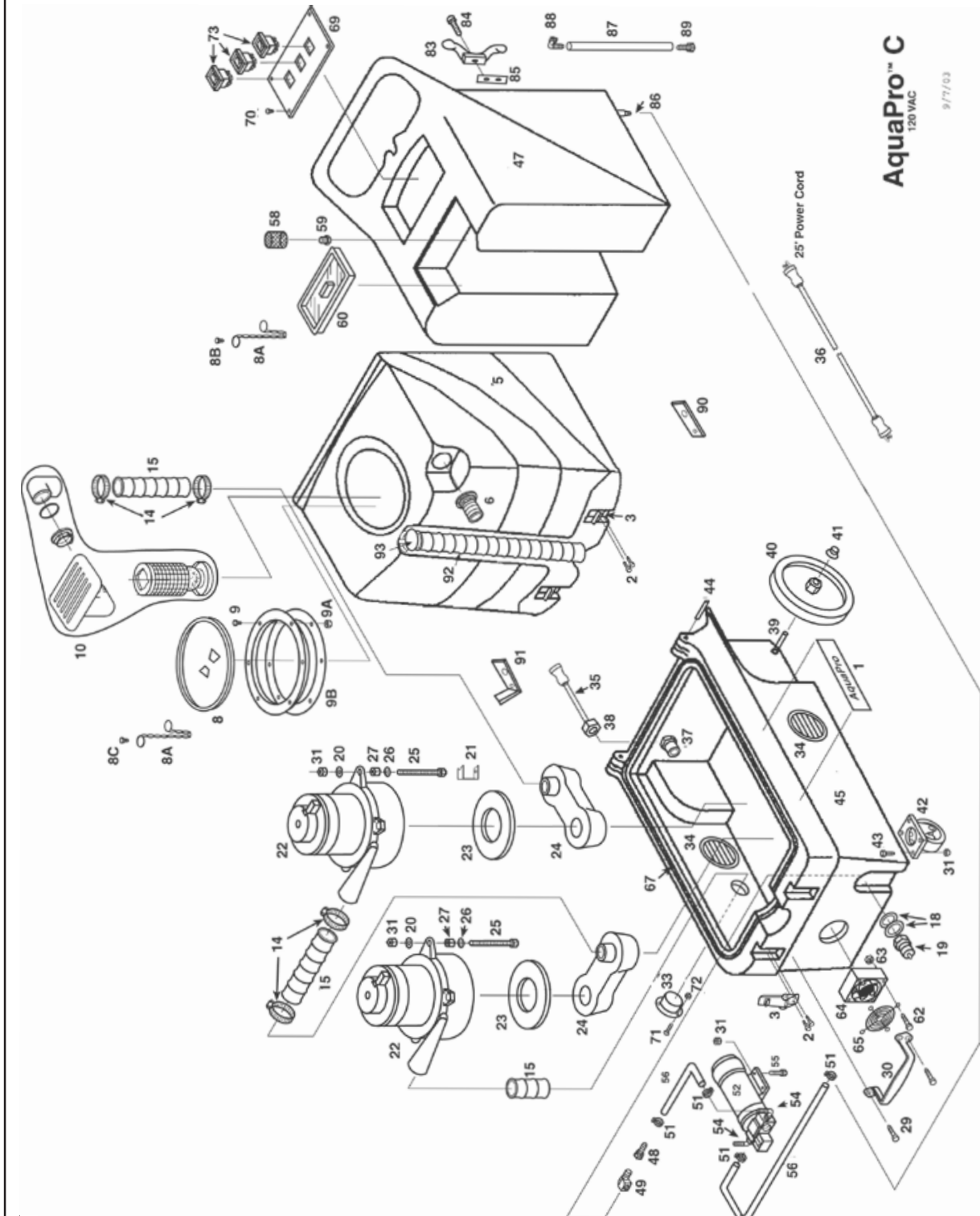

AquaPro™ C
120 VAC

9/7/03

PART LIST AquaPro™ C

Item	Ref. No.	Qty	Description	Item	Ref. No.	Qty	Description
1	56102840	2	Label, Advance AquaPro	47	56102809	1	Solution Tank, Light Gray
2	56102816	8	Screw, 8-32 x .50 (Hardware Kit)	48	56102829	1	Hose Barb, Brass (Hose Barb Kit)
3	56108074	2	Latch, Rubber W/Strike	49	56102829	1	Elbow, Brass (Hose Barb Kit)
5	56102808	1	Recovery Tank, Light Gray	51	56102817	4	Hose Clamp (Hose Clamp Kit)
6	56108061	1	Vac Inlet Hose Barb	52	56102851	1	Pump, 150 PSI, 120V
8	56108055	1	Lid, 6", Clear Center, Includes Ring	54	56102829	2	Hose Barb, Elbow (Hose Barb Kit)
8A	56108054	2	Chain, 8" (also included in Solution Lid Kit 56102812)	55	56102816	4	Bolt, 1/4-20 x 1.25 (Hardware Kit)
8B	56102812	1	Screw, 10-32 x .38 (Solution Lid Kit)	56	56102839	1	Hose, 3/8" x 76"
8C	56102816	1	Screw, 10-32 x .62 (Hardware Kit)	58	56102853	1	Filter, Pump Inlet
9	56102816	6	Screw, 8-32 x .88 (Hardware Kit)	59	56102854	1	Nipple, PVC
9A	56102816	6	Lock Nut, 8-32 (Hardware Kit)	60	56102812	1	Lid, Solution (Solution Lid Kit)
9B	56102816	1	Gasket (Hardware Kit)	62	56102816	4	Screw, 6-32 x 2.00 (Hardware Kit)
10	56108052	1	Float, Ball & Cage on Manifold	63	56102816	4	Lock Nut, 6-32 (Hardware Kit)
14	56102817	4	Hose Clamp (Hose Clamp Kit)	64	56108096	1	Fan, 120V (Fan Kit)
15	56102841	1	Hose, Vacuum, 2" x 41"	65	56108096	1	Fan Guard (Fan Kit)
18	56102836	4	Washer, Brass (Quick Disconnect Kit)	67	56102860	1	Gasket, 7ft
19	56102836	1	Quick Disconnect, Male, 1/4 NPT (Quick Disconnect Kit)	69	56102855	1	Switch Plate
20	56102816	18	Washer, Flt, 3/16 (Hardware Kit)	70	56102816	5	Screw, #4 x .38 (Hardware Kit)
21	56102815	1	Bracket, Vacuum Motor (Bracket Kit)	71	56102816	3	Bolt, 10-32 x .62 (Hardware Kit)
22	56102818	2	Vacuum Motor, 120V (Vac Motor Kit)	72	56102816	3	Lock Nut, 10-32 (Hardware Kit)
23	56102818	2	Gasket, Vacuum Motor (Vac Motor Kit)	73	56102827	3	Switch, SPST, W/Cover
24	56102842	2	Manifold	83	56102856	2	Cord Wrap, Black
25	56102816	6	Bolt, 1/4-20 x 5.00, Fully Threaded (Hardware Kit)	84	56102816	4	Bolt, 1/4-20 x 1.00 (Hardware Kit)
26	56102816	6	Washer, 1/4, Split Lock (Hardware Kit)	85	56102815	2	Bracket, Caddy Bag (Bracket Kit)
27	56102816	6	Nut, Finish, 1/4 (Hardware Kit)	86	56102829	1	Hose Barb, Straight (Hose Barb Kit)
29	56102816	4	Bolt, 1/4-20 x .75, Flat Head (Hardware Kit)	87	56108084	1	Hose, Site, 1/2" (Solution Hose Kit)
30	56102843	1	Handle, Chrome	88	56108084	1	Hose, Barb / Elbow, 1/2" (Solution Hose Kit)
31	56102816	18	Lock Nut, 1/4 (Hardware Kit)	89	56108084	1	Hose Barb, Nylon 1/2" (Solution Hose Kit)
33	56102844	1	Flange, Exhaust	90	56102815	1	Bracket, Mating (Bracket Kit)
34	56102845	2	Louver, W/Screws	91	56102815	1	Bracket, Mating, W/Hole (Bracket Kit)
35	56102820	1	Cord, 12/3, 24", Stub (Cord Outlet Kit)	92	56108071	1	Hose, Drain, 1.50" x 24" (Dump Hose Kit)
36	56102846	1	Cord, 12/3, 25ft	93	56108071	1	Plug, Hose, Drain (Dump Hose Kit)
37	56102820	1	PVC Reducer (Cord Outlet Kit)	*	56108093	1	Label, Warning
38	56102820	1	Cord Retainer (Cord Outlet Kit)				
39	56102847	1	Axle Rod, Plated, 18.25"				
40	56102811	2	Wheel, 10" (Wheel Kit)				
41	56102811	2	Axle Cap (Wheel Kit)				
42	56102848	2	Castor, 4", No Brake				
43	56102816	8	Bolt, 1/4-20 x .75 (Hardware Kit)				
44	56102850	2	Hinge pin				
45	56102810	1	Base Compartment, Gray				
			KITS				
56108096	1		Fan Kit (#64, 65)				
56102811	1		Wheel Kit (1 each of #40, 41)				
56102812	1		Solution Lid Kit (#8B, 60 / also includes #8A)				
56102816	1		Hardware Kit (#2, 8C-9B, 20, 25-29, 31, 43, 55, 62, 63, 70-72, 84)				
56102817	1		Hose Clamp Kit (#14, 51)				
56102818	1		Vacuum Motor Kit (1 each of #22, 23)				
56102836	1		Quick Disconnect Kit (#18, 19)				
56102815	1		Bracket Kit (#21, 85, 90, 91)				
56108071	1		Dump Hose Kit (#92, 93)				
56108084	1		Solution Hose Kit (#87-89)				
56102820	1		Cord Outlet Kit (1 of each #35, 37, 38)				
56102829	1		Hose Barb Kit (#48, 49, 54, 86)				
			ACCESSORIES				
56102804	1		Single Bend Wand Assembly				
56102805	1		Double Bend Wand Assembly				
56102807	1		Extractor Hand Tool				
56102861	1		Vac Hose / Pressure Line 25ft.				
56102871	1		Vac Hose / Pressure Line 15ft.				

* = Not Shown

TECHNICAL SPECIFICATIONS

Vacuum Motor:	Two, 2-Stage
Water lift:	150"
Air Flow:	100 cfm
Amp Draw:	15 amps
Tank Construction:	Rotationally molded polyethylene
Solution Tank Capacity:	14 Gal. (53.2 L)
Recovery Tank Capacity:	13 Gal.(49.4 L)
Application Flow:	150 psi
Solution Hose Length:	15 ft. (4.5 m)
Recovery Hose Length:	15 ft. (4.5 m)
Power Cord:	One 25 ft. (7.6 m), High visibility yellow, removable
Rear Wheels:	10 in. (25 cm)
Front Castors:	4 in. (10.2 cm)
Height:	38 in. (96.5 cm)
Length:	36 in (91.4 cm)
Width:	17.6 in (44.7 cm)
Machine weight:	72 lb (33 kg)

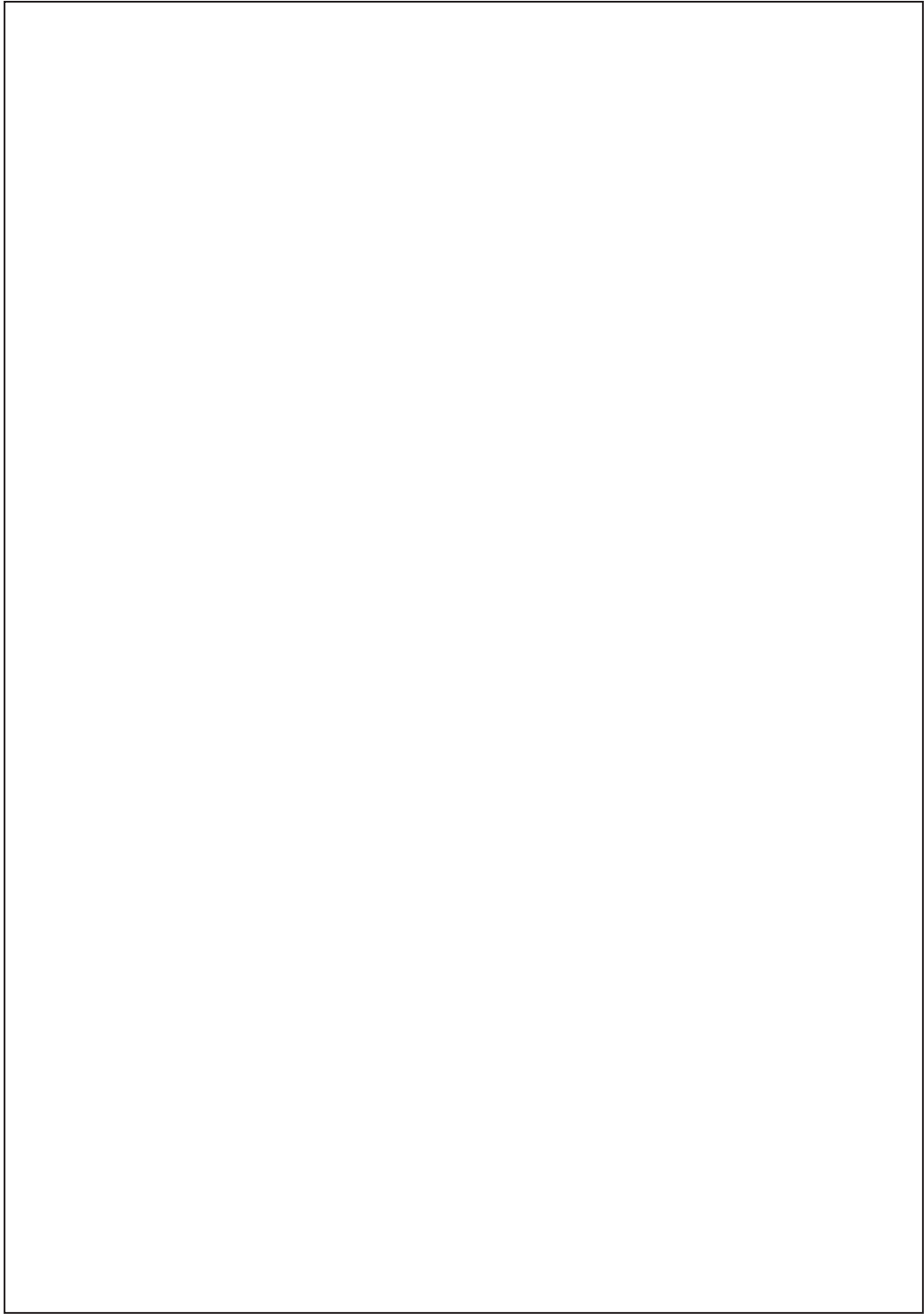



Advance

14600 21st Avenue North
Plymouth, MN 55447-3408

www.advance-us.com

Phone: 800-989-2235

Fax: 800-989-6566

©2010 Nilfisk-Advance, Inc.

A Nilfisk-Advance Brand