

PARTS LIST  
**CHARGER 2716 AB**

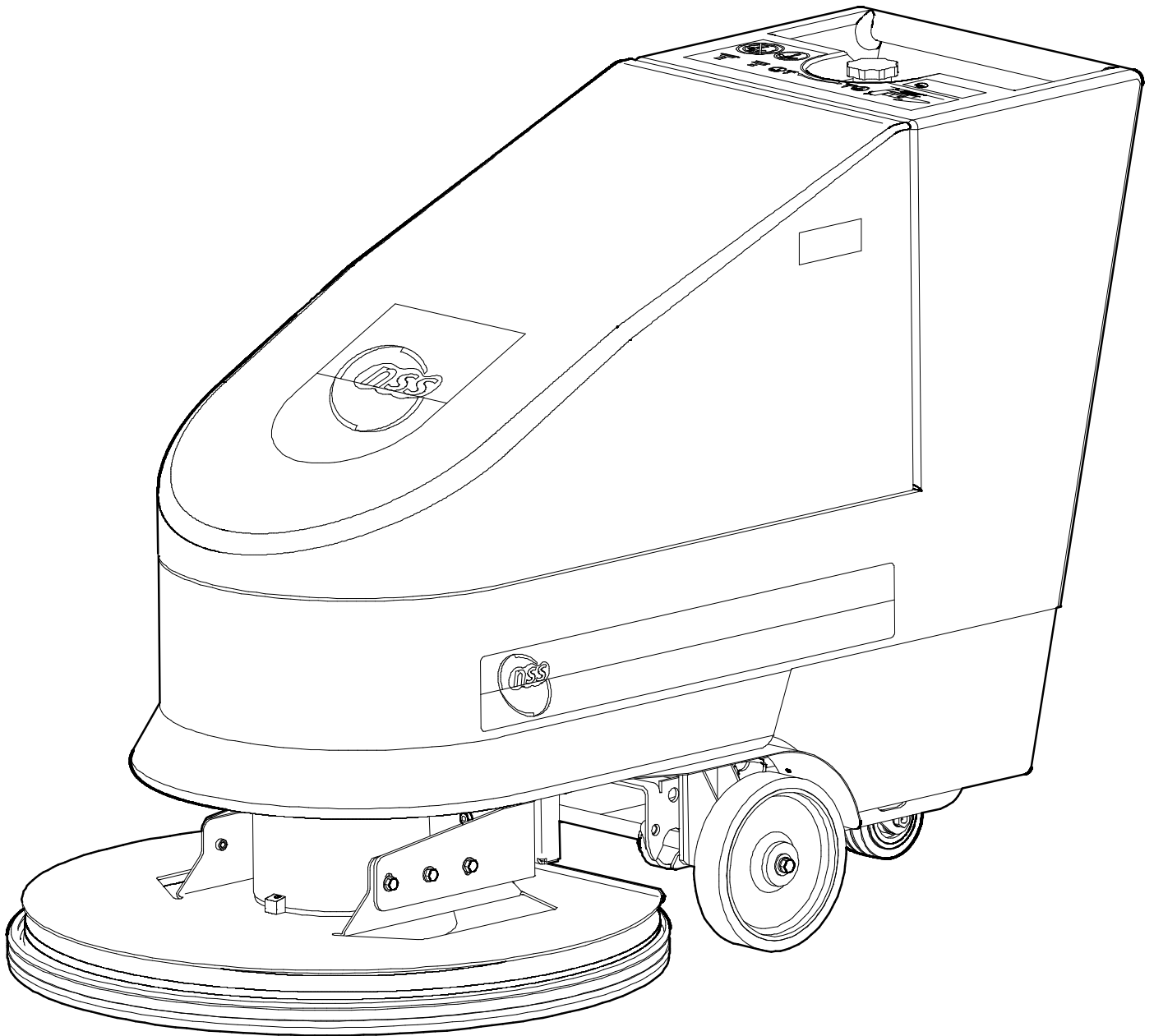

<u>ITEM</u>	<u>PART NO.</u>	<u>DESCRIPTION</u>	<u>QTY.</u>
101	6495511	CONTROL FRAME WELDMENT	1
102	9121390	11/32 I.D. X 11/16 O.D. X .051/.080 THICK SAE FLAT WASHER (5/16)	2
103	9121450	5/16-18 HEX NUT WITH NY-LOK INSERT	2
104	6495071	BASE PLATE	1
105	6495831	HINGE PLATE	2
106	9120930	9/32 I.D. X 5/8 O.D. X .051/.080 THICK SAE FLAT WASHER (1/4)	4
107	9120880	1/4 SPLIT LOCK WASHER	4
108	9121210	1/4-20 X 5/8 HEX BOLT	4
109	9121390	11/32 I.D. X 11/16 O.D. X .051/.080 THICK SAE FLAT WASHER (5/16)	2
110	9121520	5/16 SPLIT LOCK WASHER	2
111	9121640	5/16-18 X 3/4 HEX BOLT	2
112	7690311	3/8 DIAMETER X 2.5 CLEVIS PIN	1
113	6495881	SPRING GUIDE	1
114	3190191	STRING GUARD	2
115	6495871	COMPRESION SPRING	1
116	5390811	1/2 X 1 X .07 THICK FLAT WASHER - NYLATRON	2
117	6495891	PIVOT	1
118	5091701	RETAINING RING	1
119	6491871	END COUPLING ROUND BEAD CHAIN	1
120	9120380	10-24 X 3/8 ROUND HEAD PHILLIPS MACHINE SCREW	1
121	9120330	10 EXTERNAL STAR LOCK WASHER	1
122	6491860	ROUND BEAD CHAIN (CUT LENGTH 6")	.5
123	9121270	1/4-20 X 1 HEX BOLT	2
124	4894461	RUBBER STOP	2
125	6490701	CATCH ASSEMBLY	1
126	9122100	3/8 SPLIT LOCK WASHER	4
127	9122220	3/8-16 X 3/4 HEX BOLT	4
128	6492061	RED 4 INCH CASTER - INCLUDES:	1
	4490391	CASTER WHEEL WITH BEARING	1
129	9122260	3/8-16 X 1 HEX BOLT	4
130	9122100	3/8 SPLIT LOCK WASHER	4
131	6495141	CASTER MOUNT	1
132	9120900	1/4-20 HEX NUT WITH NY-LOK INSERT	2
133	9120930	9/32 I.D. X 5/8 O.D. X .051/.080 THICK SAE FLAT WASHER (1/4)	2
134	6495151	FRAME	1
135	9122180	13/32 I.D. X 13/16 O.D. X .051/.080 THICK WROUGHT WASHER (3/8)	4
136	9122260	3/8-16 X 1 HEX BOLT	4
137	9122100	3/8 SPLIT LOCK WASHER	4
138	2691181	PIVOT SPACER, STABILIZER BAR	2
139	6490201	SUPPORT-LEG, SHAFT COLLAR	2
140	6495241	BASE LEG CHARGER - LEFT	1
141	6492221	AXLE, BASE PLATED	1
142	9122260	3/8-16 X 1 HEX BOLT	4
143	9122100	3/8 SPLIT LOCK WASHER	4
144	6495271	AXLE BLOCK	2
145	6495231	BASE LEG CHARGER - RIGHT	1
146	9120637	1/4-20 X 1/4 SET SCREW - CUP POINT	2
147	4492791	BUSHING, PIVOT	2
148	9122450	17/32 I.D. X 1 1/16 O.D. X .074/.121 THICK SAE FLAT WASHER (1/2)	2
149	9122420	1/2 SPLIT LOCK WASHER	2
150	9122540	1/2-13 X 1 1/4 HEX BOLT	2
151	9122260	3/8-16 X 1 HEX BOLT	2
152	9122100	3/8 SPLIT LOCK WASHER	2
153	9122180	13/32 I.D. X 13/16 O.D. X .051/.080 THICK WROUGHT WASHER (3/8)	2
154	4490511	WHEEL - 8"	2
155	9122495	1/2-13 HEX NUT WITH NY-LOK INSERT - THIN	2
156	6492211	BASE ASSEMBLY LEG EXTENDER	2
157	9122540	1/2-13 X 1 1/4 HEX BOLT	2
158	9122420	1/2 SPLIT LOCK WASHER	2
159	9122450	17/32 I.D. X 1 1/16 O.D. X .074/.121 THICK SAE FLAT WASHER (1/2)	2
160	6490691	LIFT ARM	2
161	4495141	LIFT ARM SPACER	2
162	6495501	PIVOT WELDMENT	1
163	7690491	#6 HAIR COTTER PIN	1
164	4492791	BUSHING, PIVOT	2
165	9122450	17/32 I.D. X 1 1/16 O.D. X .074/.121 THICK SAE FLAT WASHER (1/2)	2
166	9122540	1/2-13 X 1 1/4 HEX BOLT	2
167	9122220	3/8-16 X 3/4 HEX BOLT	6
168	9122100	3/8 SPLIT LOCK WASHER	6
169	9121470	5/16-18 X 1 FLAT HEAD PHILLIPS MACHINE SCREW	2

# BASE

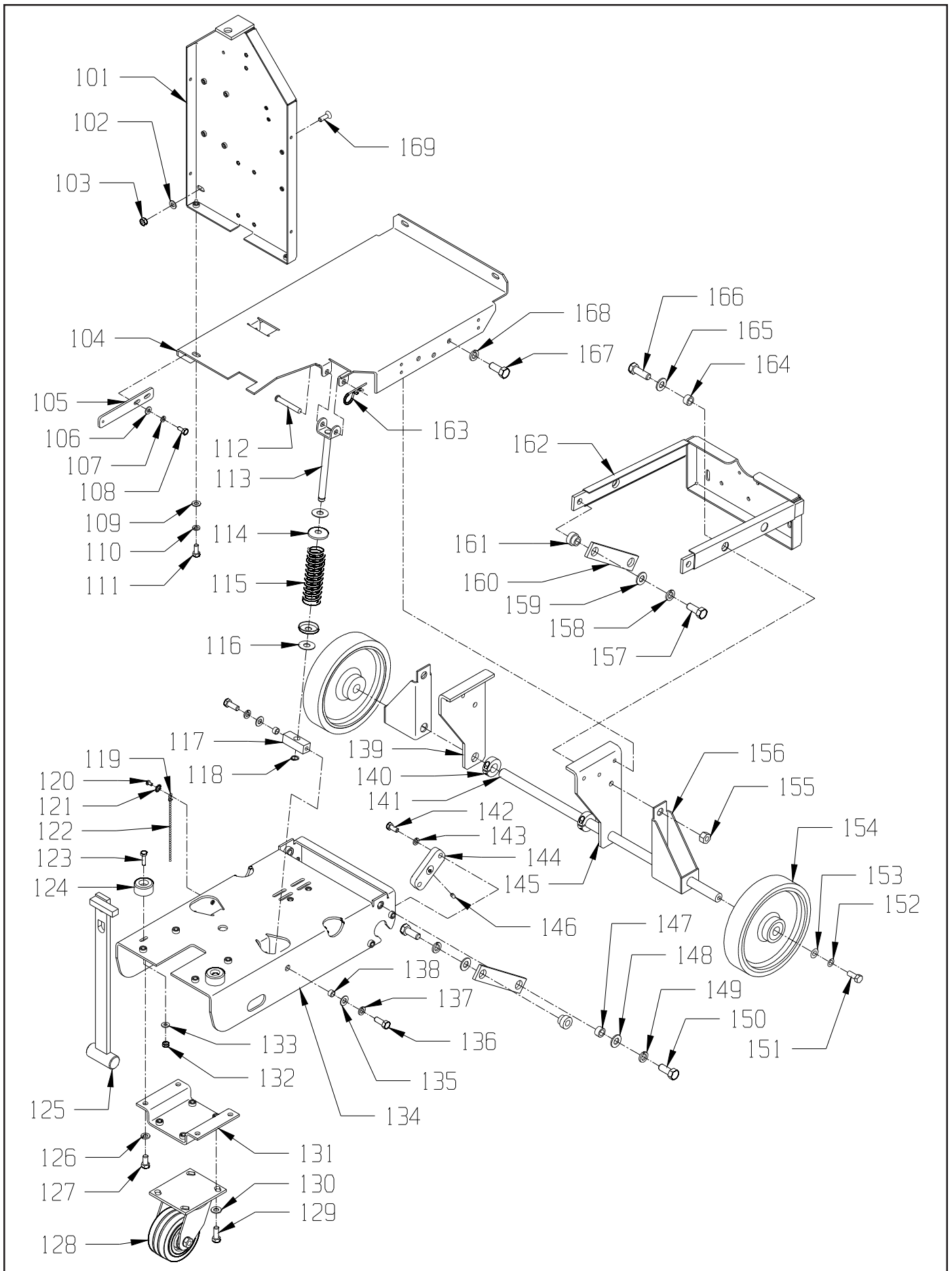

<b>ITEM</b>	<b>PART NO.</b>	<b>DESCRIPTION</b>	<b>QTY.</b>
201	6492051	STUD TERMINAL BOOT - RUBBER	2
202	6495641	MOTOR 36 VOLT	1
203	6495093	STEEL SKIRT / MOTOR MOUNT	1
204	6492163	PIVOT FORK	1
205	9121390	11/32 I.D. X 11/16 O.D. X .051/.080 THICK SAE FLAT WASHER (5/16)	4
206	9121520	5/16 SPLIT LOCK WASHER	4
207	9121640	5/16-18 X 3/4 HEX BOLT	4
208	9121390	11/32 I.D. X 11/16 O.D. X .051/.080 THICK SAE FLAT WASHER (5/16)	3
209	9121520	5/16 SPLIT LOCK WASHER	3
210	9121640	5/16-18 X 3/4 HEX BOLT	3
211	6495501	PIVOT WELDMENT	1
212	4495531	END CUFF - 2"	1
213	3392561	VAC EXHAUST HOSE	1
214	4495441	HOSE CLAMP, 1 9/16" - 2 1/2" DIAMETER	1
215	6495459	CW-FLEXIWALL SHIELD ASSEMBLY - INCLUDES:	1
215A	6592552	BUMPER STRAP	1
215B	9120350	10-24 HEX NUT WITH NY-LOK INSERT	1
215C	9120450	10-24 X 1 ROUND HEAD PHILLIPS MACHINE SCREW	1
215D	6592531	BUMPER / BRUSH	1
216	6492558	DRIVER, PAD - 27" ASSEMBLED & BALANCED	1
217	9121985	13/32 I.D. X 1 O.D. X .12 THICK FLAT WASHER (11 GAGE)	1
218	9121520	5/16 SPLIT LOCK WASHER	1
219	9121490	5/16-24 X 7/8 HEX BOLT	1
220	5990731	SPRING CLIP PAD HOLDER SET - INCLUDES:	1
220A	9120810	10 X 1/2 PAN HEAD PHILLIPS SHEET METAL SCREW	3
221	9120815	3/16 SQUARE X 1/2 LONG KEY - STEEL	1
222	9120980	1/4-20 X 1 SOCKET HEAD CAP SCREW	3
223	9120880	1/4 SPLIT LOCK WASHER	3
224	9120950	1/4 X 1 1/4 FENDER WASHER	3
225	5796101	PAPER BAG - 5 PACK	1
	6592801	VAC TRAC COLLECTION BAG - OPTIONAL	1
226	9122020	3/8 DIAMETER X 3/8 LONG SOCKET HEAD SHOULDER BOLT (5/16-18)	2
227	9121400	3/8 I.D. X 7/8 O.D. X .064/.104 THICK WROUGHT WASHER	2
228	2691181	PIVOT SPACER	2
229	9997590	METAL CORE QUICKEDGE TRIM (CUT TO 66")	5.5'

# SHIELD AND PAD DRIVER

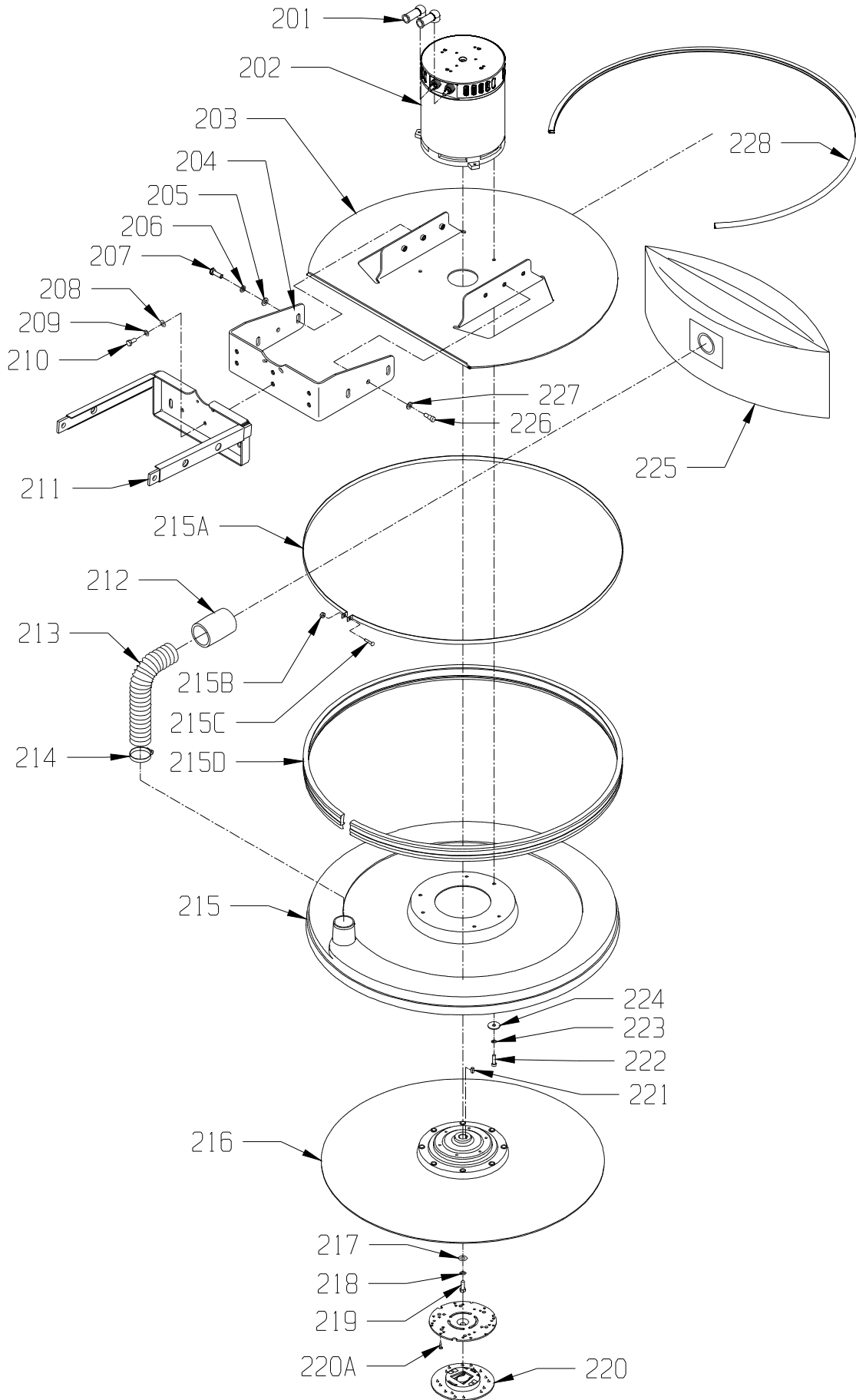

<b>ITEM</b>	<b>PART NO.</b>	<b>DESCRIPTION</b>	<b>QTY.</b>
301	4490521	LOAD ADJUST KNOB (INCLUDES SET SCREW)	1
302	9122450	17/32 I.D. X 1 1/16 O.D. X .074/.121 THICK SAE FLAT WASHER (1/2)	2
303	9122705	1/2 I.D. X 3/4 O.D. X .01 THICK 1 WAVE SPRING WASHER (1/2)	1
304	6490611	ADJUSTMENT ROD	1
305	6490621	ADJUSTMENT ROD COLLAR	2
306	9122180	13/32 I.D. X 13/16 O.D. X .051/.080 THICK SAE FLAT WASHER (3/8)	1
307	4490561	INSULATED STANDOFF	1
308	9120970	1/4 EXTERNAL STAR LOCK WASHER	1
309	9121210	1/4-20 X 5/8 HEX BOLT	1
310	4491011	SOLENOID, 36 VOLT	1
311	9120930	9/32 I.D. X 5/8 O.D. X .051/.080 THICK SAE FLAT WASHER (1/4)	2
312	9120880	1/4 SPLIT LOCK WASHER	2
313	9121170	1/4-20 X 1/2 HEX BOLT	2
314	2791281	BUSHING SPACER	2
315	9121287	1/4-20 X 2 1/2 HEX BOLT - STEEL	1
316	2791281	BUSHING SPACER	2
317	9120930	9/32 I.D. X 5/8 O.D. X .051/.080 THICK SAE FLAT WASHER (1/4)	2
318	9120900	1/4-20 HEX NUT WITH NY-LOK INSERT	2
319	6490601	ADJUSTMENT BRACKET	1
320	4495326	SWITCH BRACKET	1
321	9120370	7/32 I.D. X 1/2 O.D. X .032/.065 THICK SAE FLAT WASHER (10)	2
322	9120320	10 SPLIT LOCK WASHER	2
323	9120460	10-24 X 1 1/4 ROUND HEAD PHILLIPS MACHINE SCREW	2
324	4491071	SNAP SWITCH	1
325	9120130	6 EXTERNAL STAR LOCK WASHER	2
326	9120090	6-32 X 7/8 PAN HEAD PHILLIPS MACHINE SCREW	2
327	9120900	1/4-20 HEX NUT WITH NY-LOK INSERT	2
328	4490601	KNOB, RAISE / LOWER ROD	1
329	6490101	LATCH HANDLE	1
330	6490091	LATCH ASSEMBLY	1
331	4490631	COMPRESSION SPRING	1
332	9122450	17/32 I.D. X 1 1/16 O.D. X .074/.121 THICK SAE FLAT WASHER (1/2)	2
333	4495351	SPACER GUIDE	4
334	9120880	1/4 SPLIT LOCK WASHER	4
335	9121270	1/4-20 X 1 HEX BOLT	4
336	6490701	CATCH ASSEMBLY	1
337	9120920	1/4-20 HEX NUT	2
338	9120970	1/4 EXTERNAL STAR LOCK WASHER	2
339	9120410	10-24 X 1/2 ROUND HEAD PHILLIPS MACHINE SCREW	2
340	9120320	10 SPLIT LOCK WASHER	2
341	4491031	SHUNT	1
342	9123005	1/8 X 5 1/2 WIRE TIE	4
343	6495511	CONTROL FRAME WELDMENT	1
344	9120970	1/4 EXTERNAL STAR LOCK WASHER	2
345	9121270	1/4-20 X 1 HEX BOLT	2
346	4492801	TOP SUPPORT BRACKET	1
347	9121640	5/16-18 X 3/4 HEX BOLT	2
348	9121520	5/16 SPLIT LOCK WASHER	2
349	9121390	11/32 I.D. X 11/16 O.D. X .051/.080 THICK SAE FLAT WASHER (5/16)	2
350	9121400	3/8 I.D. X 7/8 O.D. X .064/.104 THICK WROUGHT WASHER (5/16)	2
351	9121480	5/16-18 X 1 ROUND HEAD PHILLIPS MACHINE SCREW	2
352	9121160	1/4-20 X 3/8 HEX BOLT	1
353	9120880	1/4 SPLIT LOCK WASHER	4
354	9120310	1/8 X 3/4 COTTER PIN	3

# CONTROL FRAME

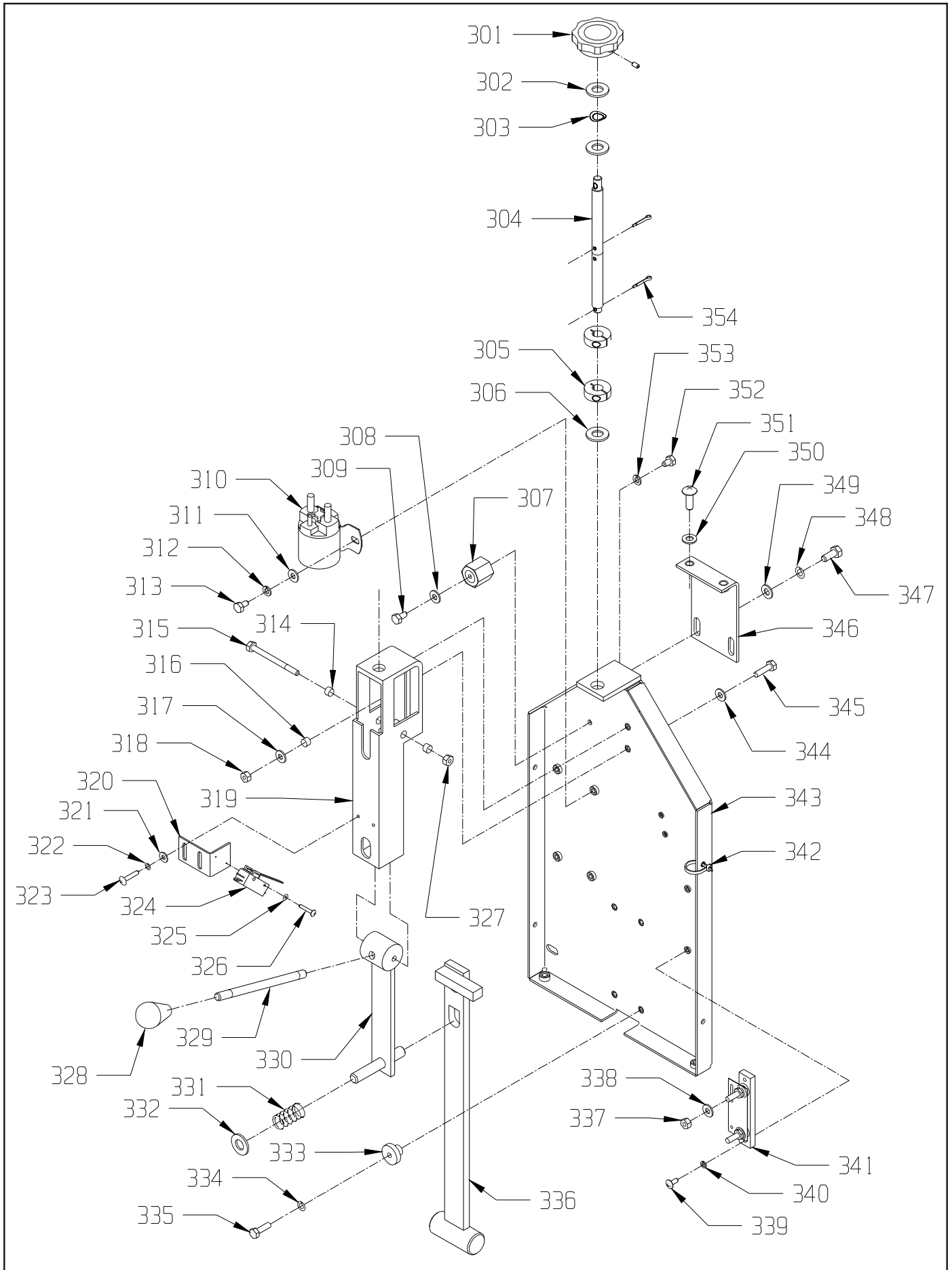

<b>ITEM</b>	<b>PART NO.</b>	<b>DESCRIPTION</b>	<b>QTY.</b>
401	9120317	5/32 X 5/8 DOME HEAD POP RIVET - STEEL	4
402	9120185	5/32 I.D. X 1/2 O.D. WASHER - STEEL - ZINC PLATE	4
403	6492261	RUBBER MOTOR COVER	1
404	6491171	SOFT DRAW LATCH WITH CONCEALED KEEPER	1
405	3392561	VAC EXHAUST HOSE	1
406	6495851	BATTERY WARNING DECAL - OBC	1
407	6491171	SOFT DRAW LATCH WITH CONCEALED KEEPER	1
408	9121400	3/8 I.D. X 7/8 O.D. X .064/.104 THICK WROUGHT WASHER (5/16)	2
409	9121480	5/16-18 X 1 ROUND HEAD PHILLIPS MACHINE SCREW	2
410	4490521	LOAD ADJUST KNOB - INCLUDES:	1
410A	9120650	10-32 X 3/4 SET SCREW	1
411	6495791	ENGLISH/SPANISH OPERATION DECAL	1
412	6493101	NAME IDENTIFIER DECAL CHARGER 2716 AB	1
413	6492801	DASH PANEL DECAL	1
414	6490951	1/4 MIPT PLUG	2
415	6490011	HOUSING WITH SLIDE RAILS	1
415A	6495441	SLIDE RAIL, LEFT	1
415B	9120920	1/4-20 HEX NUT	4
415C	9121039	1/4-20 X 1 1/2 ELEVATOR BOLT - ZINC PLATED	4
415D	9120900	1/4-20 HEX NUT WITH NY-LOK INSERT	6
415E	9120930	9/32 I.D. X 5/8 O.D. X .051/.080 THICK SAE FLAT WASHER (1/4)	6
415F	6495431	SLIDE RAIL, RIGHT	1
415G	9121037	1/4-20 X 5/8 FLAT HEAD PHILLIPS HEAD PHILLIPS MACHINE SCREW	6
416	9120790	#10 X 5/8 PAN HEAD PHILLIPS SHEET METAL SCREW	10
417	6492243	RIGHT FENDER	1
	6492233	LEFT FENDER	1
418	6493061	SIDE DECAL - 3.5 X 26	2
419	6491211	TAPPING PLATE	2
420	6491191	HOOD STOP / SUPPORT BRACKET	2
421	9120930	9/32 I.D. X 5/8 O.D. X .051/.080 THICK SAE FLAT WASHER (1/4)	4
422	9120880	1/4 SPLIT LOCK WASHER	4
423	9121270	1/4-20 X 1 HEX BOLT	4
424	4495531	END CUFF - 2"	1
425	5796101	PAPER BAG - 5 PACK	1
	6592801	CLOTH FILTER BAG (OPTIONAL)	1
426	9120185	5/32 I.D. X 1/2 O.D. WASHER - STEEL - ZINC PLATE	4
427	9120317	5/32 X 5/8 DOME HEAD POP RIVET - STEEL	4
428	6492871	HOOD DECAL	1
429	3393991	OBC WARNING DECAL	1



# HOUSING

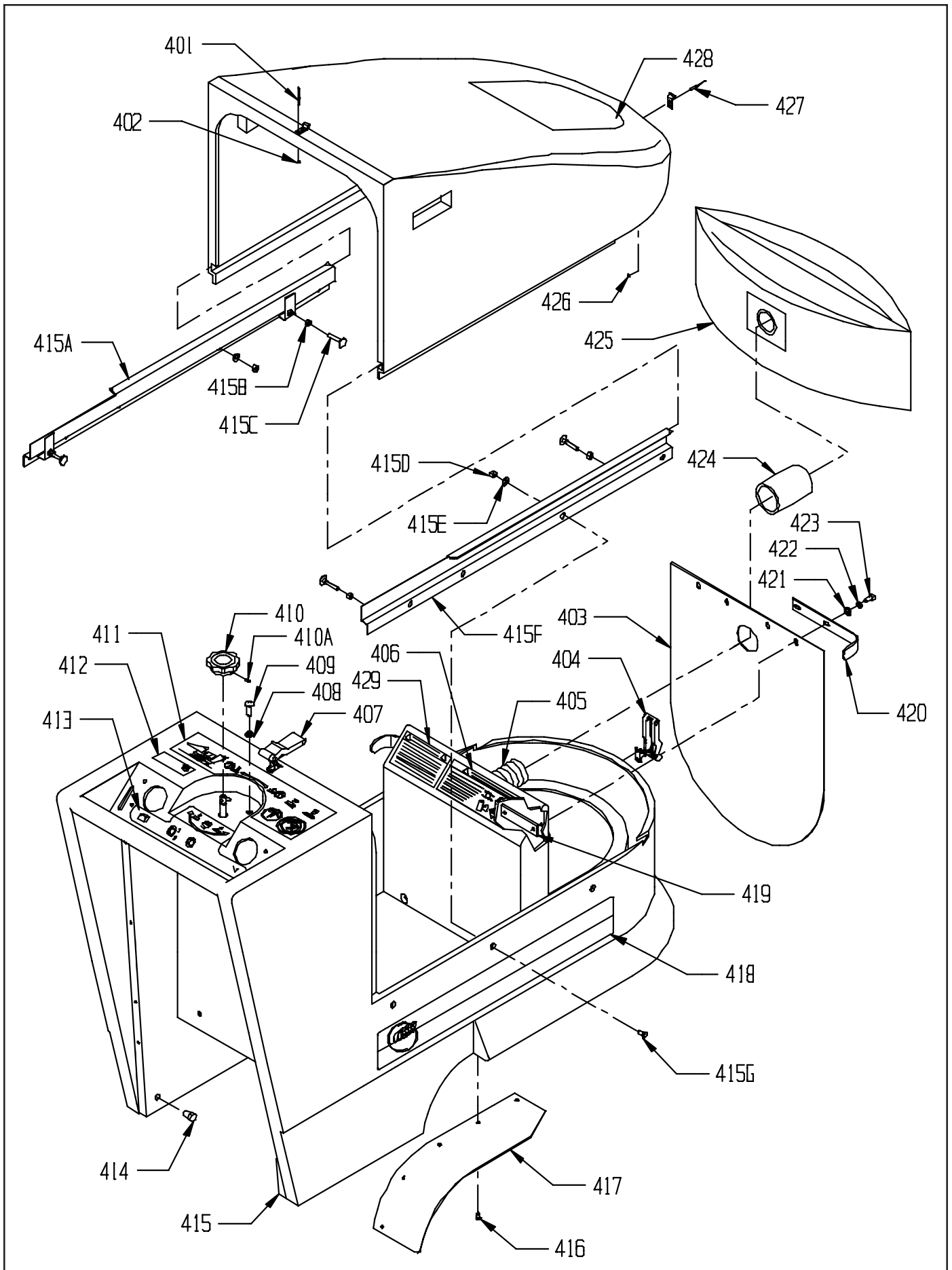

<b>ITEM</b>	<b>PART NO.</b>	<b>DESCRIPTION</b>	<b>QTY.</b>
501	4491041	RPM METER WITH HARDWARE	1
502	2691981	LIGHT - INDICATOR, GREEN, 35 VOLT, WITH CLIP	1
503	4491101	TOGGLE SWITCH, MOTOR	1
504	9122465	.516 I.D. X .813 O.D. X .027/.030 THICK FLAT WASHER	1
505	0691851	1/2 INTERNAL STAR LOCK WASHER	1
506	0798821	5/8 HEX NUT	1
507	9120900	1/4-20 HEX NUT WITH NY-LOK INSERT	2
508	9120930	9/32 I.D. X 5/8 O.D. X .051/.080 THICK SAE FLAT WASHER (1/4)	2
509	9122120	3/8 I.D. X 5/8 O.D. X .031 THICK 1 WAVE SPRING WASHER (3/8)	4
510	2791281	BUSHING SPACER	2
511	9120090	6-32 X 7/8 PAN HEAD PHILLIPS MACHINE SCREW	2
512	9120040	6 INTERNAL STAR LOCK WASHER	2
513	4491071	SNAP SWITCH	1
514	4491051	BATTERY METER 36 VOLT	1
515	9122180	13/32 I.D. X 13/16 O.D. X .051/.080 THICK SAE FLAT WASHER (3/8)	2
516	4492881	SWITCH PLATE - LEFT	1
517	9121270	1/4-20 X 1 HEX BOLT	2
518	4492901	SWITCH PLATE - RIGHT	1
519	9120510	10-24 X 1/2 TRUSS HEAD PHILLIPS MACHINE SCREW	4
520	4493046	HANDLE	1
521	9120350	10-24 HEX NUT WITH NY-LOK INSERT	1
522	6491261	CIRCUIT BREAKER - 90 AMP/ETA	1
523	4490641	EXTENSION SPRING	1
524	9120360	10-24 HEX NUT WITH STAR LOCK WASHER	1
525	9120370	7/32 I.D. X 1/2 O.D. X .032/.065 THICK SAE FLAT WASHER (10)	1
526	9120480	10-24 X 1 3/4 ROUND HEAD PHILLIPS MACHINE SCREW	1
527	2397361	HOUR METER (OPTIONAL)	1
528	9120790	10 X 5/8 PAN HEAD PHILLIPS SHEET METAL SCREW	8
529	6495813	UPPER REAR PANEL	1
530	4990321	FUSE HOLDER W/NUT & WASHER	1
531	6495741	3AG FAST-ACTING FUSE 4AMP	1
532	6492891	DECAL PAD POSITION	1
533	6495823	LOWER REAR PANEL	1
534	4890451	BUSHING, SNAP, #SB87511 HEYCO	1
535	6495691	36 VOLT ONBOARD CHARGER 120/240 VOLT 21 AMP	1
536	9121020	1/4-20 X 1 TRUSS HEAD PHILLIPS MACHINE SCREW	1
537	9120085	M3.5 X 19 PAN HEAD PHILLIPS MACHINE SCREW	2
538	2491283	CORD WRAP	1
539	9121000	1/4-20 X 5/8 TRUSS HEAD PHILLIPS MACHINE SCREW	3
540	9120880	1/4 SPLIT LOCK WASHER	4
541	9120930	9/32 I.D. X 5/8 O.D. X .051/.080 THICK SAE FLAT WASHER (1/4)	4
542	3291111	CABLE CLAMP	1
543	9121550	5/16 DIA. X 3/8 LONG SOCKET HEAD SHOULDER BOLT 1/4-20	2
544	9120890	1/4-20 HEX NUT WITH NY-LOK INSERT - THIN	2
545	6495831	HINGE PLATE	2
546	4890851	CABLE CLAMP, #COV-090 KMC	1
547	9120900	1/4-20 HEX NUT WITH NY-LOK INSERT	1
548	6495861	WIRING DECAL AB WITH ONBOARD CHARGER	1
549	6495701	120 VOLT ONBOARD CHARGER CORD	1
	6495711	240 VOLT ONBOARD CHARGER CORD - SHUKO	1

# CONTROL PANEL

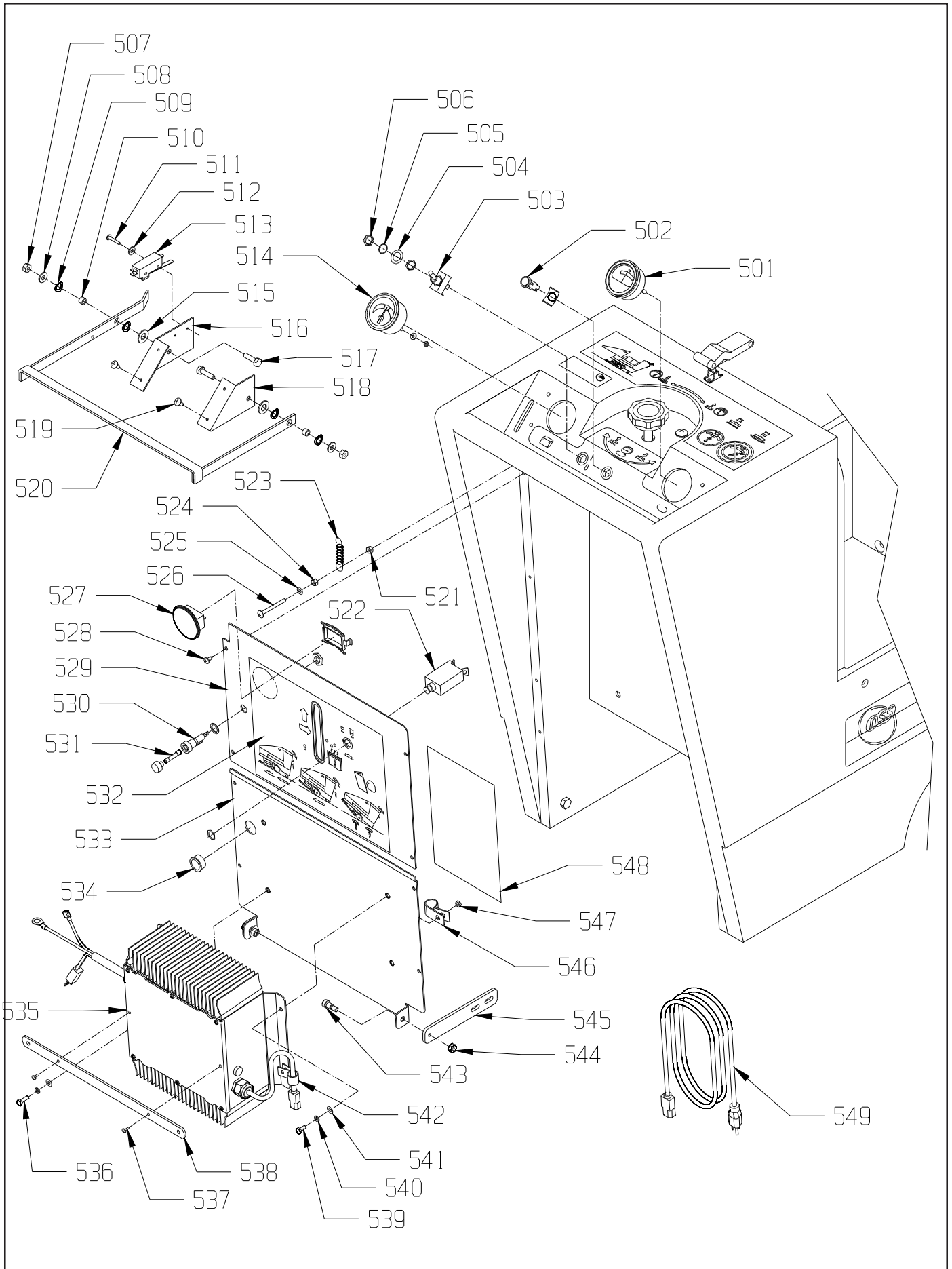

<u>ITEM</u>	<u>PART NO.</u>	<u>DESCRIPTION</u>	<u>QTY.</u>
1	6490801	WIRE ASSEMBLY, BREAKER TO SHUNT	1
2	6490811	WIRE ASSEMBLY, SOLENOID TO BREAKER	1
4	6495121	WIRE ASSEMBLY, SHUNT TO MOTOR	1
5	6495131	WIRE ASSEMBLY, MOTOR TO STANDOFF	1
6	6495721	WIRE ASSEMBLY, FUSE TO SWITCH	1
7	6490861	WIRE ASSEMBLY, SOLENOID / LIGHT / VOLT METER TO STANDOFF	1
8	6490871	WIRE ASSEMBLY. SAFETY SWITCH TO VOLT METER / SWITCH TO LIGHT	1
9	6490881	WIRE ASSEMBLY, HANDLE SWITCH TO SAFETY SWITCH	1
10	6490891	WIRE ASSEMBLY, SOLENOID TO HANDLE SWITCH	1
11	7691661	WIRE ASSEMBLY, ANDERSON - POS./NEG. BATTERY 36 VOLT	1
12	6495621	HOUR METER LEADS - OPTIONAL	1
17	6491831	WIRE ASSEMBLY, ANDERSON TO SOLENOID / STANDOFF	1
97	2391981	BATTERY JUMPER 3/8" RING #97	2
-	2397361	HOUR METER - OPTIONAL	1
-	2691981	INDICATOR LIGHT - GREEN LENS / 35 VOLT WITH CLIP	1
-	4490561	INSULATED STANDOFF	1
-	4491011	SOLENOID - 36 VOLT	1
-	4491031	SHUNT	1
-	4491041	RPM METER WITH HARDWARE	1
-	4491051	BATTERY METER 36 VOLT WITH HARDWARE	1
-	4491061	BATTERY - 210 AMP/HR, 12 VOLT	3
-	4491071	SNAP SWITCH	2
-	4491101	TOGGLE SWITCH - MOTOR	1
-	4990321	FUSE HOLDER WITH NUT & WASHER	1
-	6491261	CIRCUIT BREAKER - 90 AMP/ETA	1
-	6491841	175 AMP ANDERSON WITH CONTACTS GRAY 36 VOLT	2
-	6492251	MOTOR, 36 VOLT - 1500 RPM - 3 HP	1
-	6495691	36V ONBOARD CHARGER 120/240V 21AMP	1
-	6495701	120V ONBOARD CHARGER CORD	1
-	6495711	240V ONBOARD CHARGER CORD - SHUKO	1
-	6495741	3AG FAST-ACTING FUSE 4AMP	1
-	9123005	1/8 X 5 1/2 WIRE TIE	6



# MOTOR

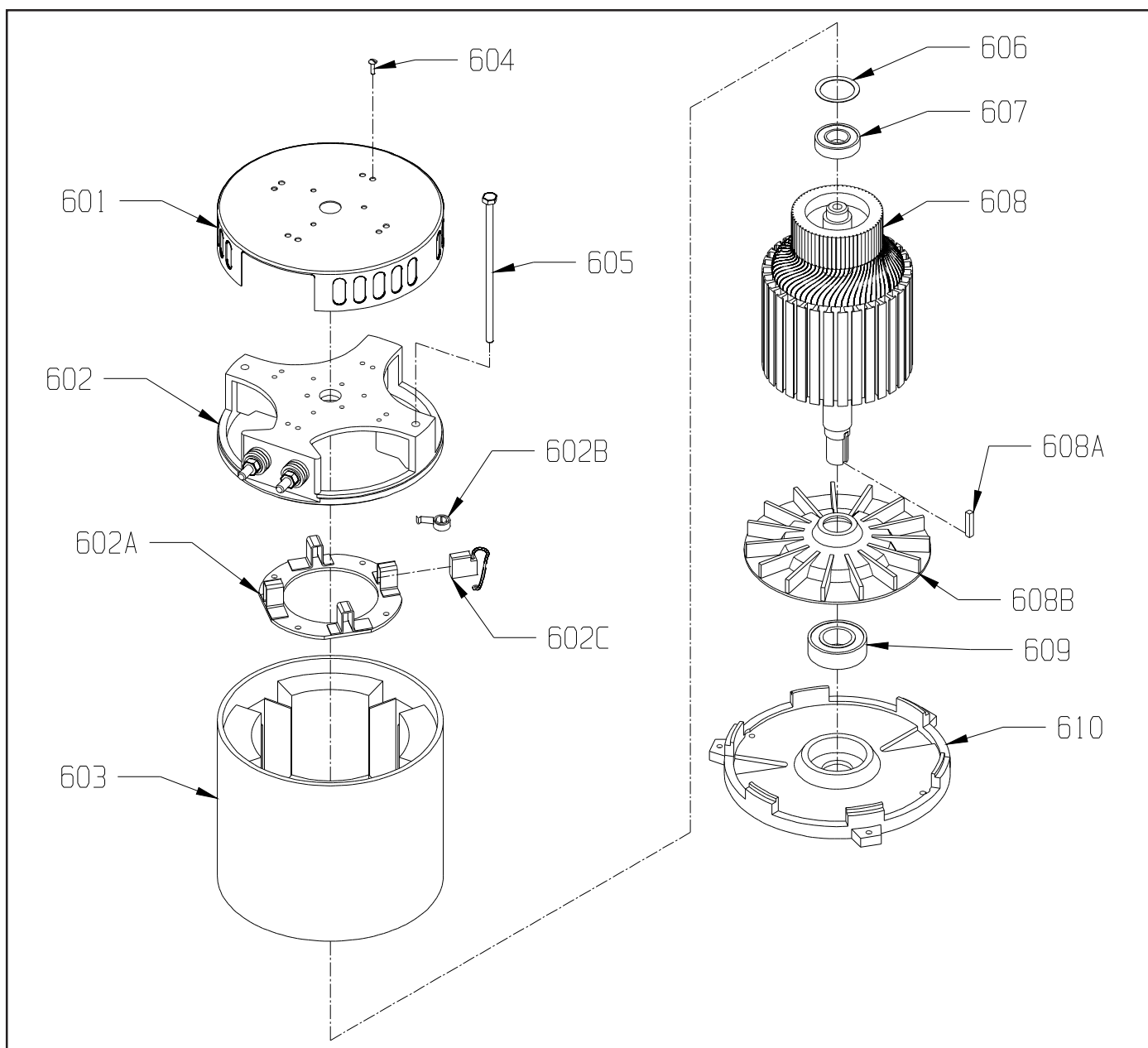

<u>ITEM</u>	<u>PART NO.</u>	<u>DESCRIPTION</u>	<u>QTY.</u>
	6495641	MOTOR 36 VOLT, 1500 RPM, 3 HP - INCLUDES:	1
601	5991731	COMMUTATOR BRACKET COVER	1
	6493531	COMMUTATOR BRACKET ASSEMBLY - INCLUDES:	1
602	6493541	COMMUTATOR BRACKET	1
602A	6493601	BRUSH BOARD ASSEMBLY - INCLUDES:	1
602B	6493591	SPRING	2
602C	7692041	CARBON BRUSH	2
603	6493631	STATOR FRAME ASSEMBLY - WITH CLIPS AND MAGNETS - 3 HP	1
604	9120600	10-24 X 1/2 PAN HEAD PHILLIPS THREAD CUTTING SCREW	4
605	6493621	1/4-20 X 9 HEX HEAD THRU BOLT - 3 HP	2
606	5991741	HELICAL WASHER - LARGE	1
607	5991551	BEARING - TOP END	1
608	6493641	ARMATURE - 1500 RPM - 3 HP - INCLUDES:	1
608A	9120827	3/16 SQUARE X 1 LONG KEY - STEEL	1
608B	6493571	ALUMINUM FAN	1
609	5991541	BEARING - BOTTOM END	1
610	6493551	BEARING END BRACKET	1

**BLANK**



**NSS ® Enterprises, Inc.**

3115 Frenchmens Road, Toledo, Ohio 43607

PHONE (419) 531-2121 FAX (419) 531-3761

**NSS ® Enterprises, Inc. European Distribution Centre**  
Unit II, Pinfold Trading Estate \* 55 Nottingham Road  
STAPLEFORD, NOTTINGHAM NG9 8AD ENGLAND U.K.

PHONE: (44) 0115 939 1568 \* FAX: (44) 0115 949 0615