

PARTS LIST
OUTLAW BV – DRY VACUUM

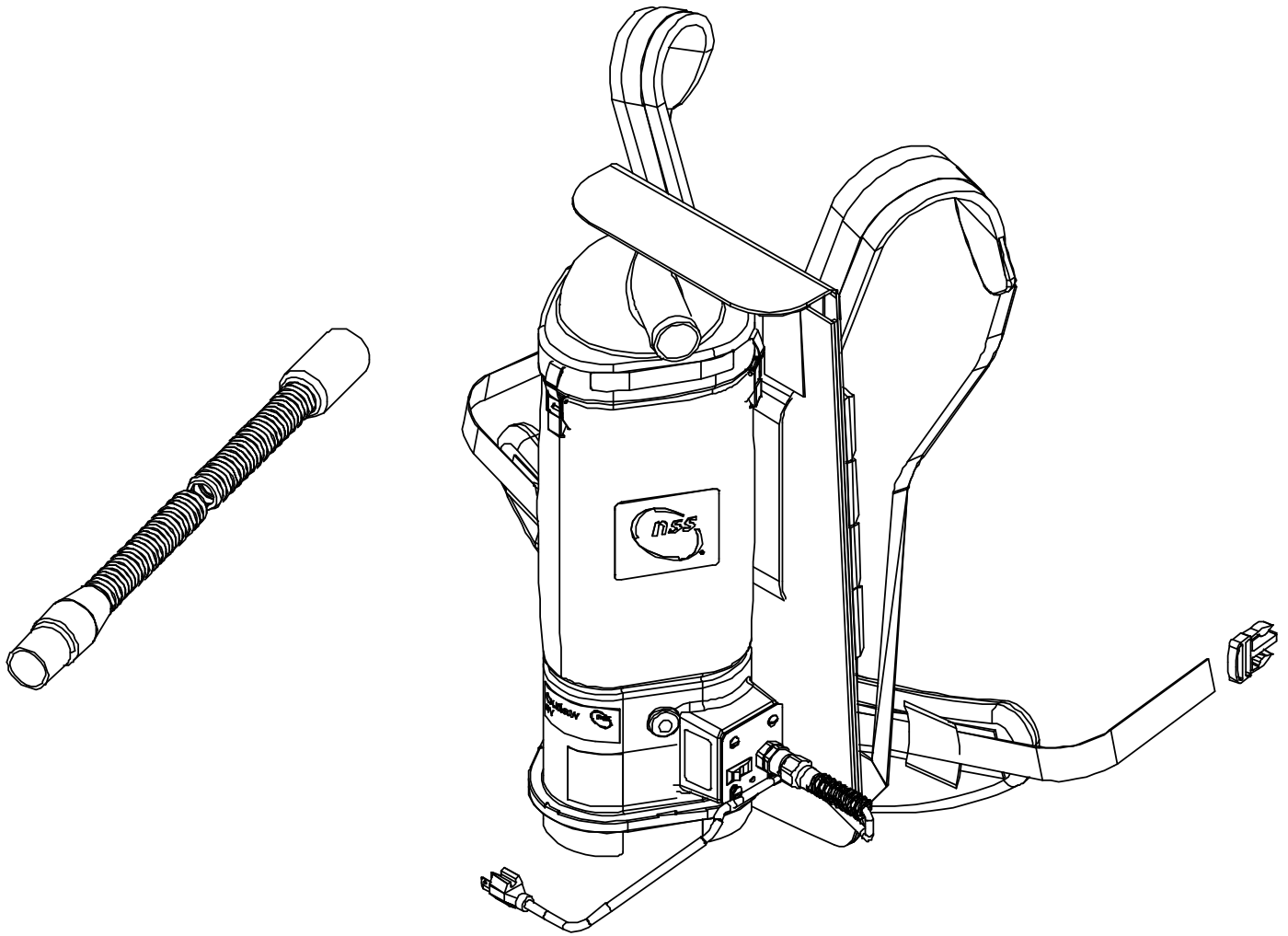

HOUSING ASSEMBLY

<u>ITEM</u>	<u>PART NO.</u>	<u>DESCRIPTION</u>	<u>QTY</u>
101	6793339	TOP COVER – INCLUDES:	1
101A	6793171	CLAMP BUTTON - BUTTON ONLY	3
101B	9120319	5/32 X 3/8 DOME HEAD POP RIVET - PACK OF 5	3
102	6793251	VACUUM HOSE - 1 5/8" I.D. X 54" LONG - INCLUDES:	1
102A	2590371	HOSE CUFF	1
102B	2595111	SWIVEL HOSE CUFF - 1 1/2" I.D.	1
102	6790241	VACUUM HOSE - 1 5/8" I.D. X 66" LONG - INCLUDES:	1
102A	2590371	HOSE CUFF	1
102B	2595111	SWIVEL HOSE CUFF - 1 1/2" I.D.	1
103	6793781	OUTLAW B/V LABEL KIT	1
104	6793011	MOLDED TANK	1
104A	9120319	5/32 X 3/8 DOME HEAD POP RIVET - PACK OF 5	3
104B	6793181	CLAMP AND BUTTON	3
105	6792791	NAME IDENTIFIER DECAL	1
106	6793081	WELLNUT (1/4-20)	3
107	6792951	1/2 O.D. X 1/4 I.D. X 1/2 SPACER	3
108	6793271	WASHER / FINISH CAP	3
109	9121010	1/4-20 X 3/4 TRUSS HEAD MACHINE SCREW - PACK OF 5	3
110	6793261	PLASTIC SCREW CAP	3
111	6793751	BACKPACK HARNESS – INCLUDES	1
111A	6990911	BUCKLE - 1 1/2"	1
112	6990581	BACKPACK ATTACHMENT PLATE	1
113	6790351	DOME FILTER	1
114	6790121	BAG – CLOTH	1
115	6790091	PAPER BAG - 10 PER PACK	1
116	0393531	NSS LOGO LABEL	2
117	9120970	1/4" EXTERNAL STAR LOCK WASHER - PACK OF 10	4
118	9121000	1/4-20 X 5/8 TRUSS HEAD PHILLIPS MACHINE SCREW - PACK OF 5	4
119	3190571	STRAIN RELIEF	1

HOUSING ASSEMBLY

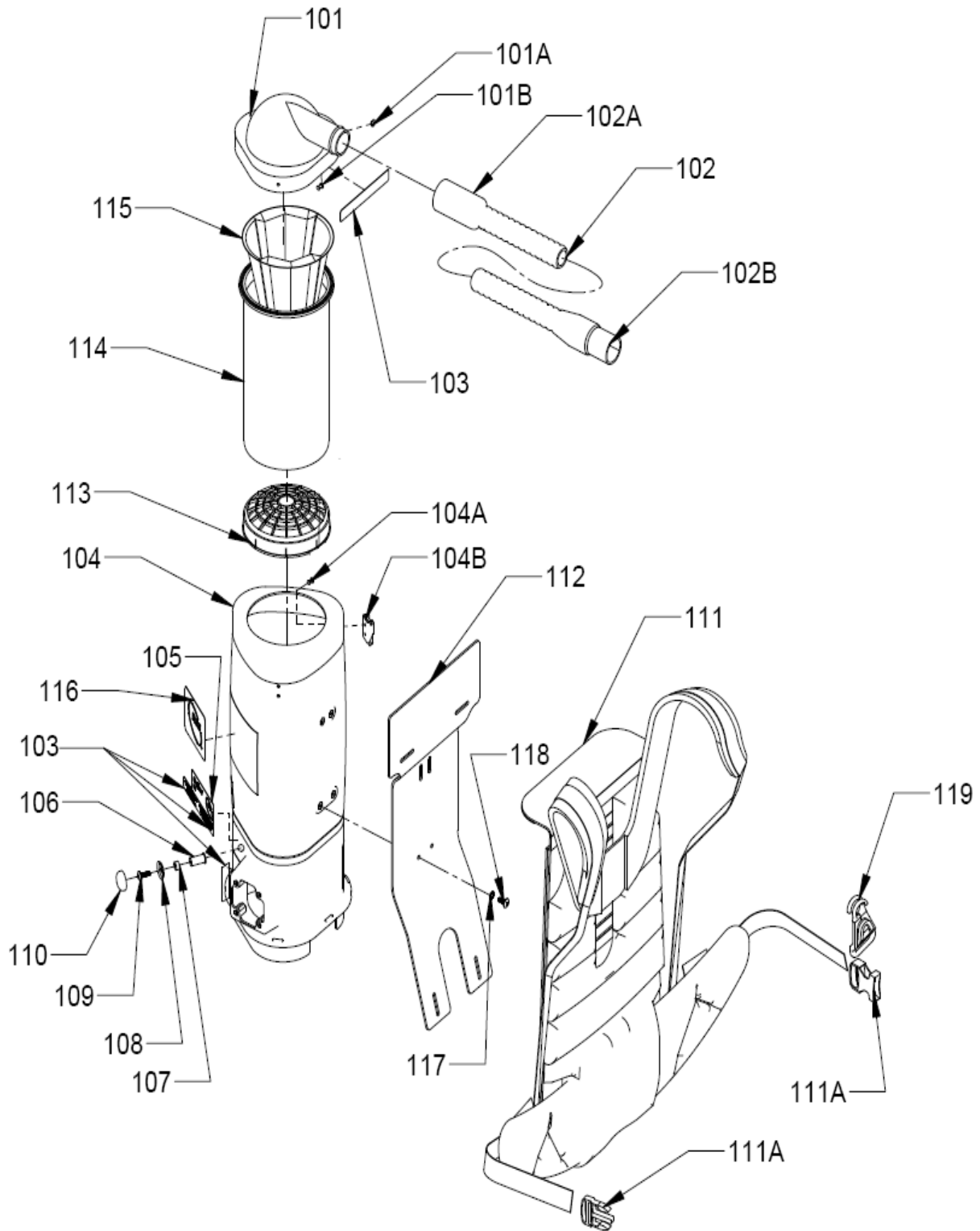

MOTOR ASSEMBLY

<u>ITEM</u>	<u>PART NO.</u>	<u>DESCRIPTION</u>	<u>QTY</u>
201	6793011	MOLDED TANK	1
201A	9120319	5/32 X 3/8 DOME HEAD POP RIVET - PACK OF 5	6
201B	6793181	CLAMP AND BUTTON	3
202	6793301	GASKET - COVER PLATE	1
203	-----	SEE WIRING DIAGRAM PAGES FOR DETAILS	1
206	9120785	#10 X 3/8 PAN HEAD PHILLIPS SHEETMETAL SCREW - PACK OF 10	1
207	6793071	VACUUM MOTOR GASKET	1
208	6793761	VACUUM MOTOR - 120 VOLT - INCLUDES:	1
208A	6793821	CARBON BRUSH - 120 VOLT	2
208	6793851	VACUUM MOTOR - 240 VOLT - INCLUDES:	1
208A	6793831	CARBON BRUSH - 240 VOLT	2
208	6790319	VACUUM MOTOR - 120V/400HZ - INCLUDES:	1
208A	6793411	CARBON BRUSH 400HZ OUTLAW	2
209	-----	TERMINALS SEE WIRING DIAGRAMS FOR DETAILS	
210	-----	GROUND WIRE SEE WIRING DIAGRAM PAGES FOR DETAILS	
211	9120320	#10 SPLIT LOCK WASHER - PACK OF 10	1
212	9120590	10-24 X 3/8 PAN HEAD PHILLIPS THREAD CUTTING SCREW - PACK OF 10	1
213	6793061	VACUUM MOTOR GASKET HOLDER	2
214	9120625	10-24 X 3/4 HEX WASHER HEAD SLOT THREAD CUTTING SCREW - PACK OF 2	4
215	6793041	PERFORATED EXHAUST COVER	1
217	6793031	FOAM EXHAUST FILTER	1
219	6790421	50 FOOT CORD - 120 VOLT	1
	6793021	50 FOOT SHUKO CORD - 240 VOLT	1
	6791141	75 FOOT AIRLINE GALLEY CORD	1
	6790231	75 FOOT AIRLINE CABIN CORD	1
220	6793771	VACUUM MOTOR CAP (120V/60Hz)	1
	3193111	VACUUM MOTOR CAP (240V & 120V/400Hz)	1

MOTOR ASSEMBLY

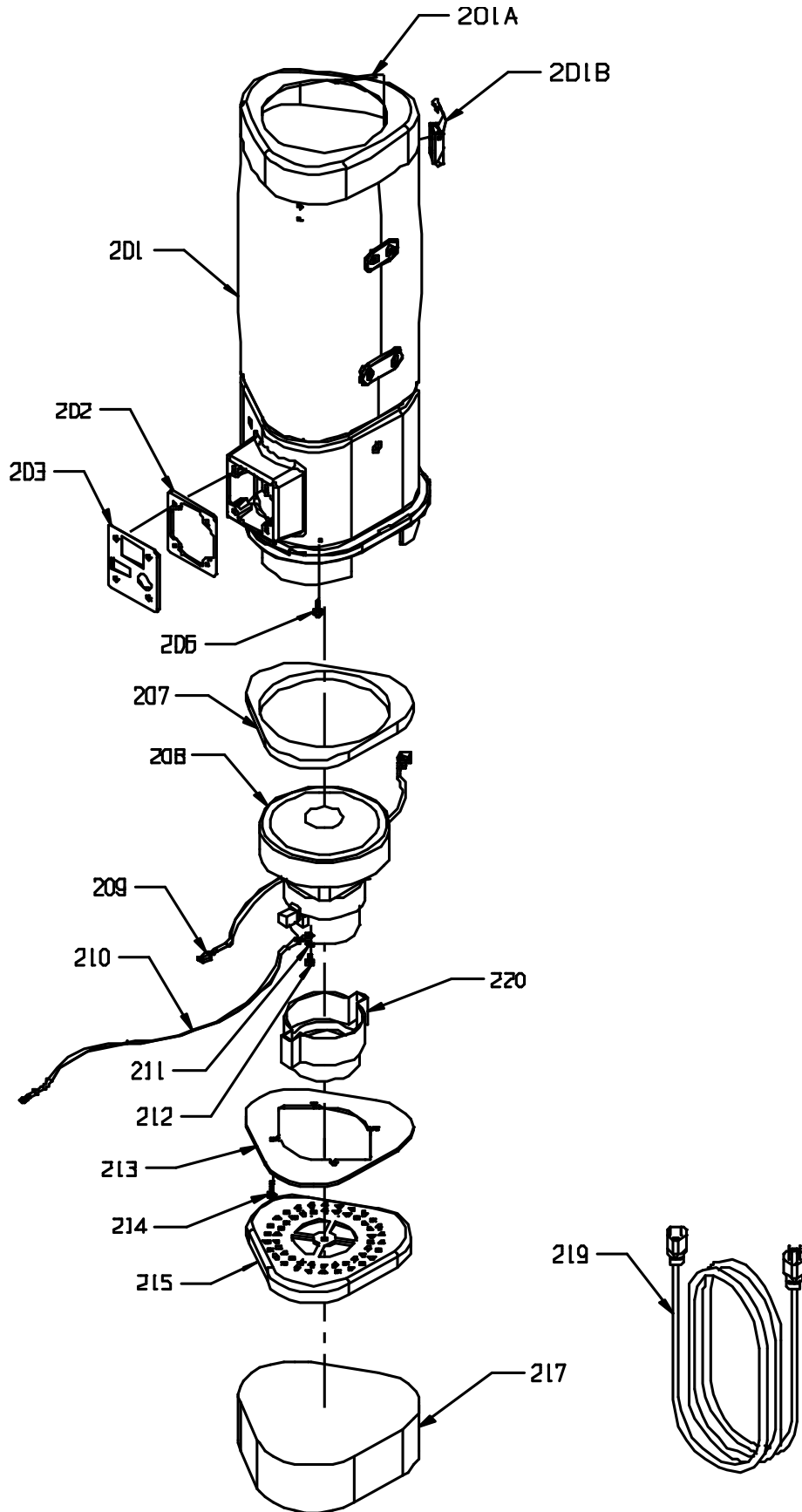

WIRE DIAGRAM – SWITCH ON BODY
120 VOLT: 6706704 – 240 VOLT: 6706709

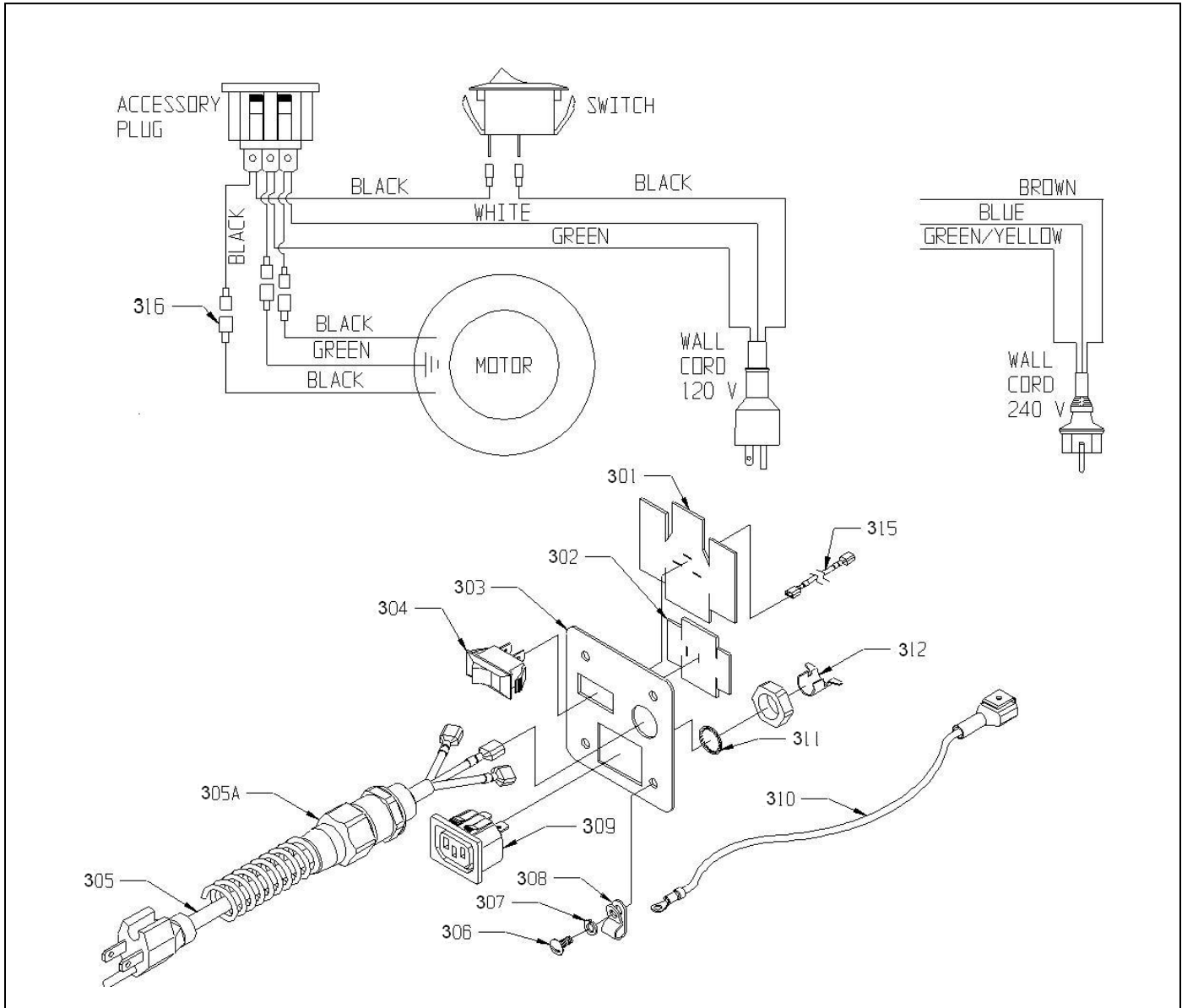

ITEM	PART NO.	DESCRIPTION	QTY.
301	6793361	GASKET - COVER – ACCESSORY PLUG	1
302	6793671	GASKET – COVER – ROCKER SWITCH	1
303	6793053	COVER PLATE	1
304	4890751	ROCKER SWITCH	1
305	6793231	PIG-TAIL CORD 120/240 VOLT - INCLUDES:	1
305A	6793221	STRAIN RELIEF - INCLUDES NUT	1
306	9120410	10-24 X 1/2 ROUND HEAD PHILLIPS MACHINE SCREW - PACK OF 10	4
307	9120320	#10 SPLIT LOCK WASHER - PACK OF 10	4
308	6793651	NYLON CABLE CLAMP	1
309	6793421	ACCESSORY OUTLET – FOR POWER WAND	1
310	6793791	GREEN WIRE, MOTOR TO ACC PLUG	1
311	9122900	3/4 INTERNAL STAR LOCK WASHER - PACK OF 5	1
312	0299661	STRAIN RELIEF CORD CLAMP	1
315	2792371	WIRE #14 X 6" #62	1
316	6793801	FULLY INSULATED FEMALE TERMINAL 18 - 22 GAGE	2

WIRE DIAGRAM – SWITCH ON BODY 120 VOLT: 6706712 (AIRCRAFT)

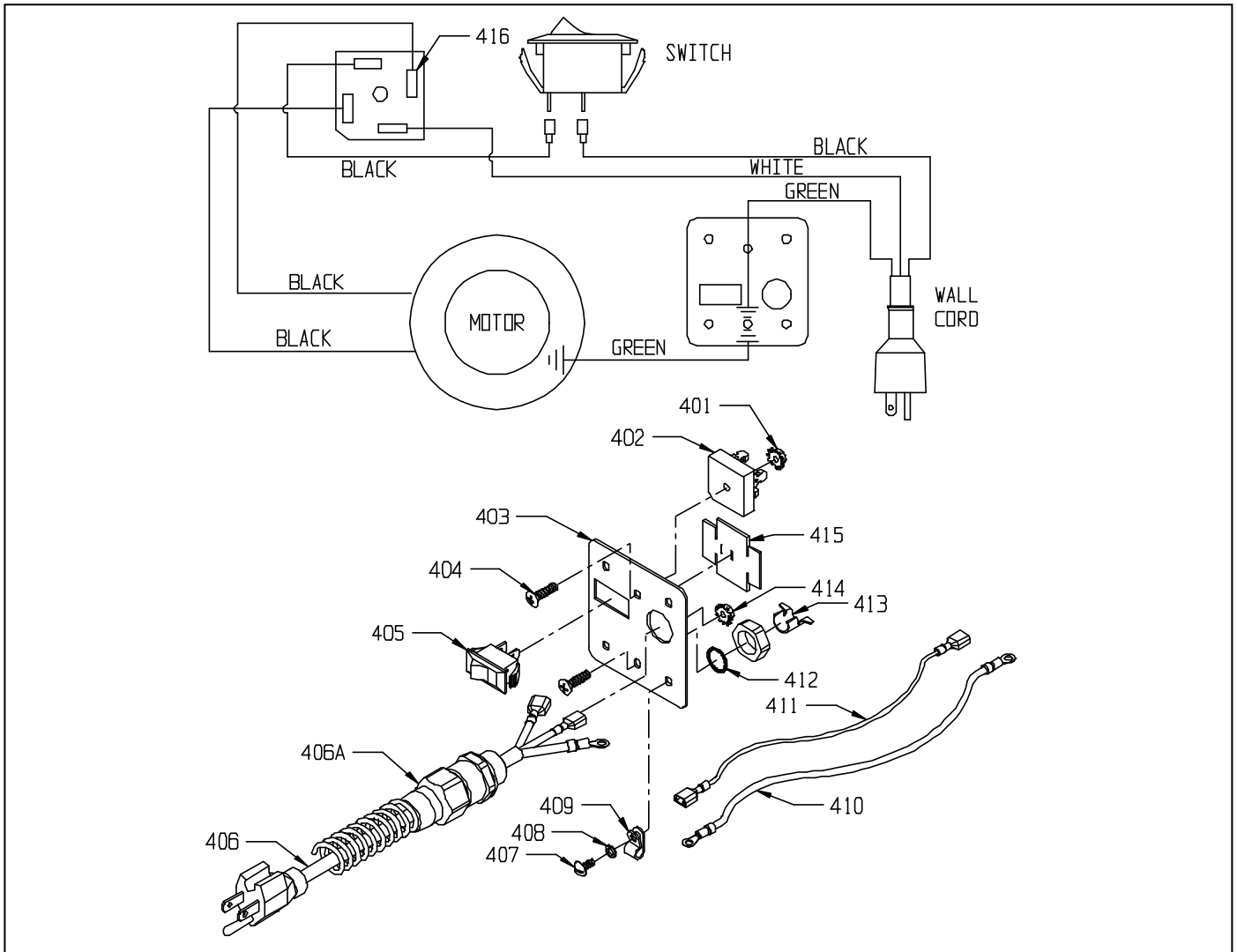

ITEM	PART NO.	DESCRIPTION	QTY.
401	9120360	10-24 HEX NUT WITH STAR LOCK WASHER - PACK OF 10	1
402	4894771	RECTIFIER	1
403	6793313	COVER PLATE	1
404	9120430	10-24 X 3/4 ROUND HEAD PHILLIPS MACHINE SCREW - PACK OF 10	2
405	4890751	ROCKER SWITCH	1
406	6793391	PIG-TAIL CORD 120 VOLT - INCLUDES:	1
406A	6793221	STRAIN RELIEF - INCLUDES NUT	1
407	9120410	10-24 X 1/2 ROUND HEAD PHILLIPS MACHINE SCREW - PACK OF 10	4
408	9120320	#10 SPLIT LOCK WASHER - PACK OF 10	4
409	6793651	NYLON CABLE CLAMP	1
410	3290691	GREEN WIRE GROUND TO MOTOR	1
411	2792371	WIRE #14 X 6" #62	1
412	9122900	3/4 INTERNAL STAR LOCK WASHER - PACK OF 5	1
413	0299661	STRAIN RELIEF CORD CLAMP	1
414	9120360	10-24 HEX NUT WITH STAR LOCK WASHER - PACK OF 10	3
415	6793671	GASKET, COVER, ROCKER SWITCH	1
416	4991361	FULLY INSULATED FEMALE TERMINAL 18 - 22 GAGE	2

HEPA FILTER ASSEMBLY - 6793459

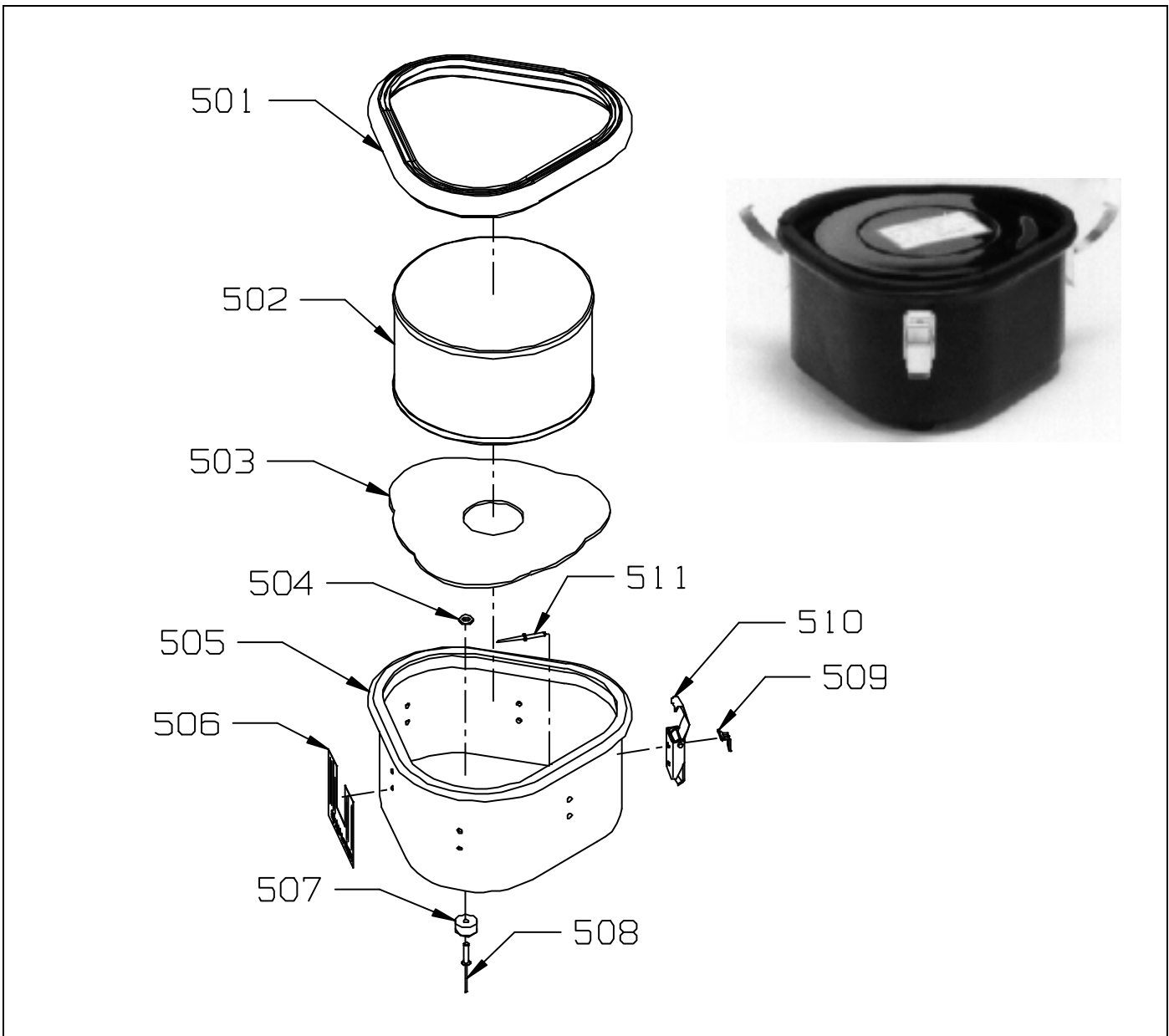

<u>ITEM</u>	<u>PART NO.</u>	<u>DESCRIPTION</u>	<u>QTY.</u>
501	6793121	GASKET - HEPA FILTER	1
502	6793111	HEPA FILTER ONLY	1
503	6793191	HEPA SEALING GASKET	1
504	9120370	7/32 I.D. X 1/2 O.D. X .032/.065 THICK FLAT WASHER - #10 - PACK OF 10	3
505	6793351	HEPA HOLDER	1
506	6793441	LABEL - HEPA	1
507	6793371	RUBBER FOOT	3
508	6793541	5/32 DIAMETER POP RIVET WITH 1/2 GRIP	3
509	6793001	SECONDARY LATCH	6
510	6793181	CLAMP AND BUTTON	6
511	9120319	5/32 X 3/8 DOME HEAD POP RIVET - PACK OF 5	12

BLOWER COVER ASSEMBLY - 6797169

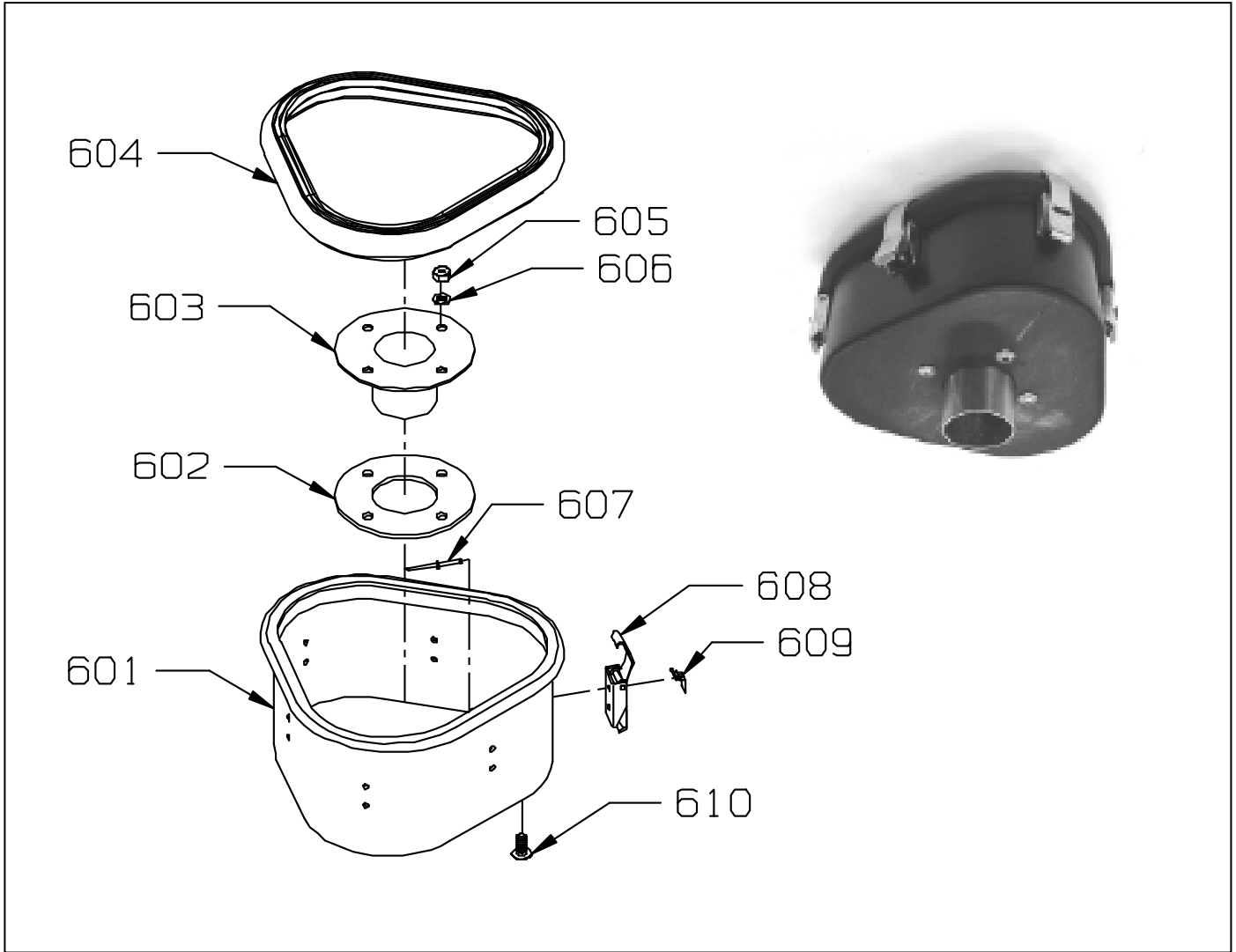

<u>ITEM</u>	<u>PART NO.</u>	<u>DESCRIPTION</u>	<u>QTY.</u>
601	6797161	BLOWER COVER	1
602	6797151	HOSE CONNECTOR GASKET	1
603	6797141	HOSE CONNECTOR	1
604	6793121	GASKET - HEPA FILTER	1
605	9120920	1/4-20 HEX NUT - PACK OF 10	4
606	9120880	1/4 SPLIT LOCK WASHER - PACK OF 10	4
607	9120319	5/32 X 3/8 DOME HEAD POP RIVET - PACK OF 5	12
608	6793181	CLAMP AND BUTTON	6
609	6793001	SECONDARY LATCH	6
610	9121000	1/4-20 X 5/8 TRUSS HEAD PHILLIPS MACHINE SCREW - PACK OF 6	4

ACCESSORIES

AIRCRAFT TOOLS

- 2290309 1 1/2" ALUMINUM TUBE HANDLE – SHORT
 3091039 1/2" CARPET TOOL - ALUMINUM SHOE
 3092323 28" ALUMINUM CREVICE TOOL



FILTERS / FILTER BAGS

- 6790091 10 PACK PAPER FILTER BAGS
 6790121 CLOTH FILTER BAG
 6793031 EXHAUST FILTER
 6790351 DOME FILTER (MOTOR)



HOSES

- 6793251 VAC HOSE - 1 5/8" I.D. X 54" LONG
 6790241 VAC HOSE - 1 5/8" I.D. X 66" LONG

POWER WAND

- 1601604 16" POWERWAND – 115 VOLT FOR USE WITH MODELS:
 6706704 OUTLAW B/V – 120 VOLT ON BOARD SWITCH WITH WAND
 6706710 OUTLAW B/V – 120 VOLT ON BELT SWITCH WITH WAND

TOOL KITS

- 6797059 DETAIL TOOL KIT
 3191469 HI-UP TUBE WITH CUFF ASSEMBLY
 5790111 TOOL - 2 1/2" ROUND BRUSH - 1 3/8" CONNECTOR END
 5790291 TOOL – CREVICE
 5790131 COMB - CARPET / BARE FLOOR TOOL 10"
 5790171 TOOL - 5 3/4" UPHOLSTERY - 5 3/4" LONG - NO BRISTLES
 5790311 NOZZLE - ADAPTOR, HOSE / ACCESSORIES
 5797299 WAND KIT

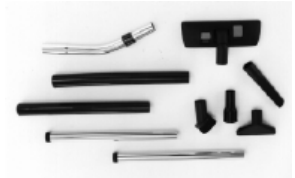

- 6790141 LITE CARPET AND DUSTING KIT
 6790151 14" CARPET AND BARE FLOOR TOOL
 6790161 2-PIECE WAND
 6790171 16" CREVICE TOOL
 6790181 3" ROUND BRUSH



- 6790069 OPEN AREA TOOL KIT - INCLUDES:
 2290309 1.5 INCH ALUM TUBE HANDLE-SHORT
 2291211 5 IN ALUM CONNECTOR
 3091859 3 INCH RD BRUSH W/NYLON INSERT
 3092311 TOOL - 1.5x28" PLASTIC CREVICE
 3097099 TOOL - 16" PLAIN SHOE



- 6790229 12" PADDLE TOOL AND WAND - INCLUDES:
 6790161 WAND - 2 PIECE
 6790211 12" PADDLE TOOL



- 6793381 TOOL TOTE

NOTES



NSS® Enterprises, Inc.

3115 Frenchmens Road, Toledo, Ohio 43607
PHONE (419) 531-2121 FAX (419) 531-3761

NSS® Enterprises, Inc. European Distribution Centre

Unit II, Pinfold Trading Estate * 55 Nottingham Road
STAPLEFORD, NOTTINGHAM NG9 8AD ENGLAND U.K.
PHONE: (44) 0115 939 1568 * FAX: (44) 0115 949 0615