



REPAIR PARTS LIST

SC6045A

FLOOR MACHINE - 20" 1.5 HP HI-SPEED BURNISHER

Date: August 5, 2003

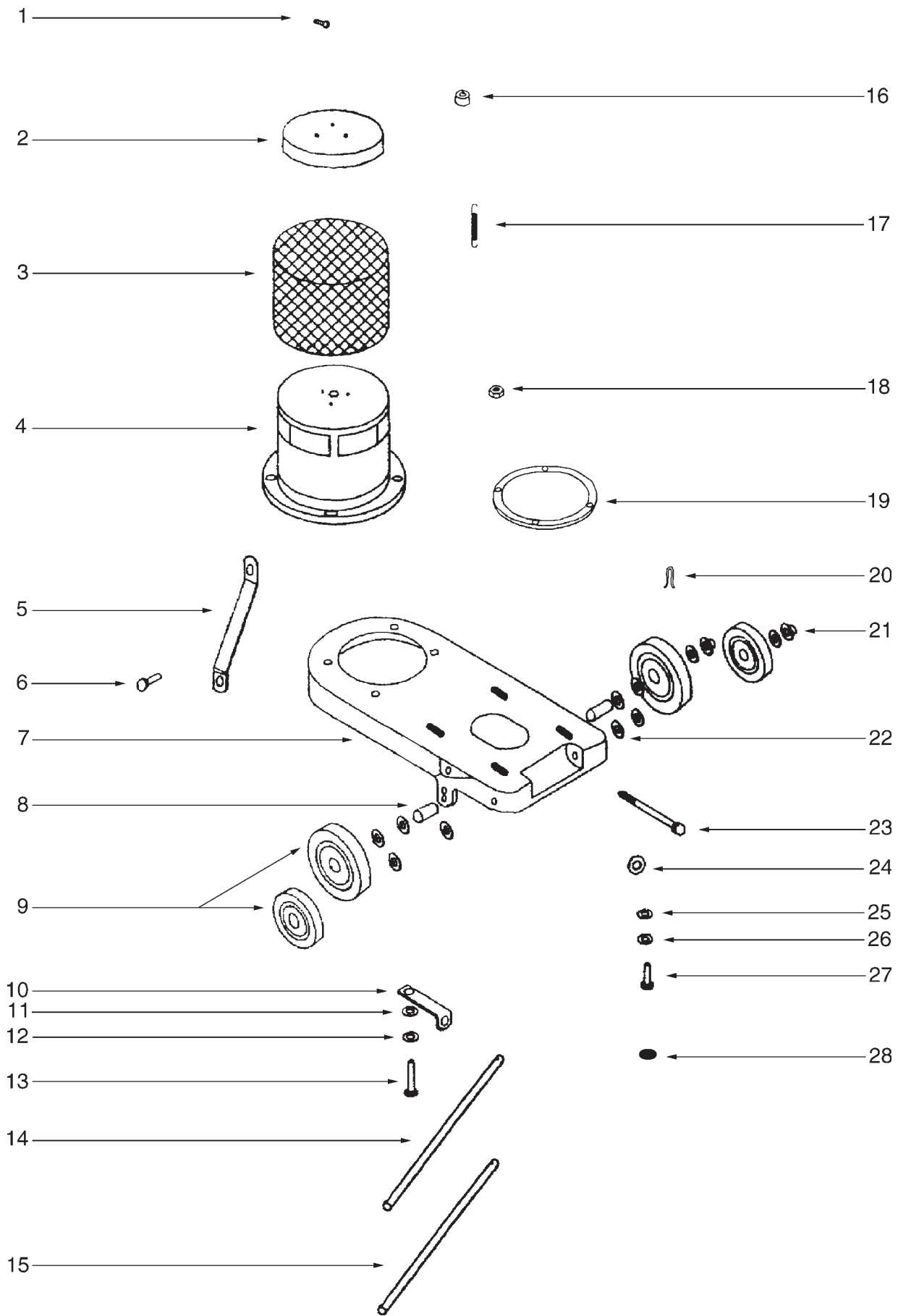

SC6045A

1.	H0002	SCREW 10 - 24 X 1"
2.	S0001CP	DRIP COVER
3.	S0016	ROLLED ALUMINUM SCREEN
4.	E00027	MOTOR
5.	S0018P-1	CONNECTING LEG
6.	H0043	BOLT .375" - 16 X 1.5"
7.	W0004P-1	FRAME
8.	M0003P	HANDLE SPACER
9.	C0004	WHEEL
10.	S0019P	BELT ADJUSTMENT BRACKET
11.	H0004	LOCK WASHER .375"
12.	H0060	FLAT WASHER .375"
13.	H0042	BOLT .375" - 16 X .875"
14.	M0017P	AXLE
15.	M0018P	HANDLE SHAFT
16.	H0003	SPACER
17.	H0049	SPRING
18.	H0057	NUT 3/8" X 16
19.	C0011P-1	BEARING HOUSING
20.	H0006	COTTER PIN
21.	H0009	PUSH NUT .5"
22.	H0008	WASHER 33/64" X 7/8"
23.	H0056-3	BOLT 1/4" - 20 X 3"
24.	H0054	LOCK WASHER .25"
25.	H0004	LOCK WASHER .375"
26.	H0060	FLAT WASHER .375"
27.	H0041	BOLT .375" - 16 X .75"
28.	H0055	PLUG BUTTON

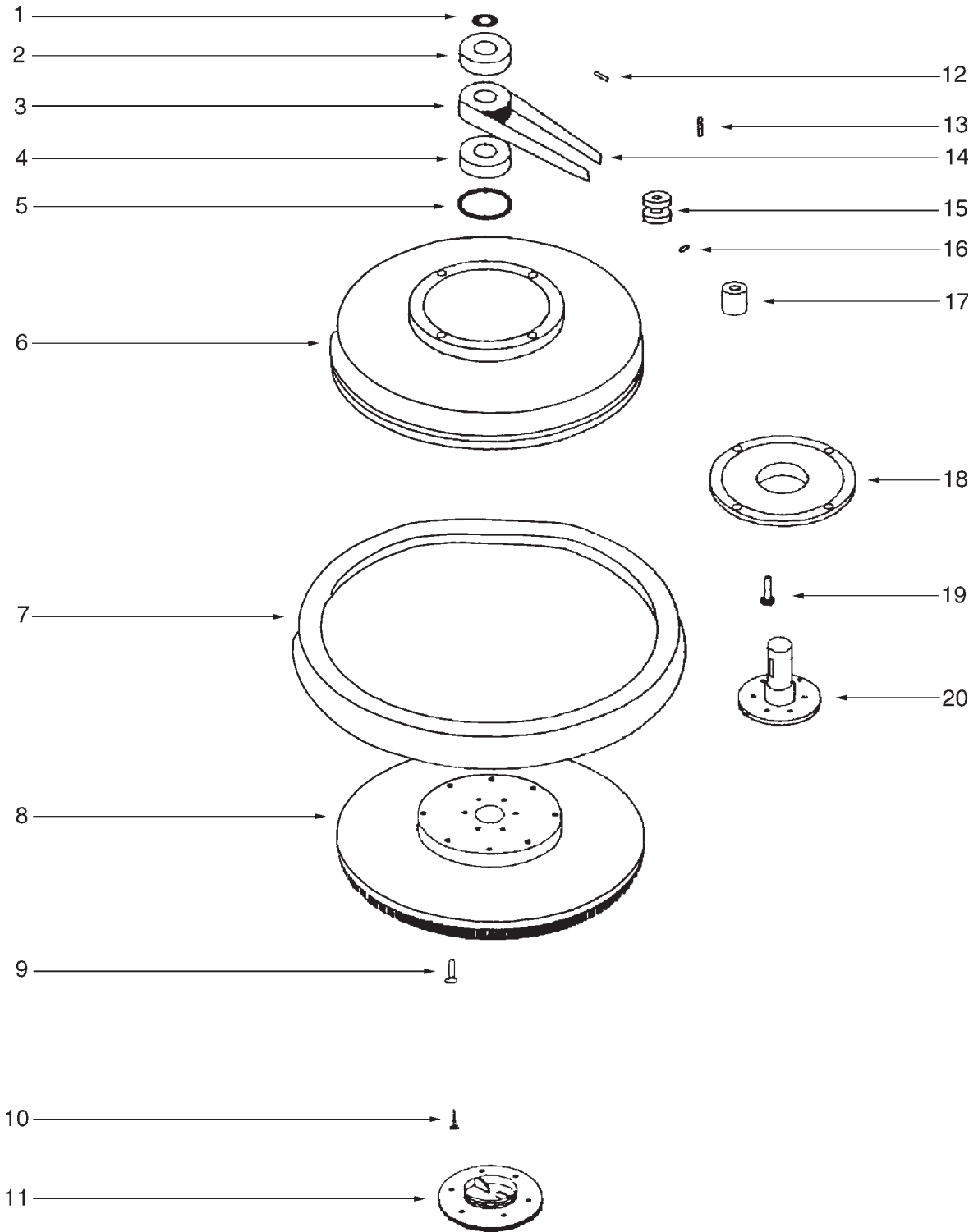

SC6045A

1.	H0045	EXTERNAL RETAINING RING
2.	M0019	BALL BEARING
3.	M0014	PULLEY
4.	M0019	BALL BEARING
5.	H0048	TENSION WASHER
6.	S0004CP	BRUSH COVER
7.	C0002-1	BUMPER
8.	C0012	PAD DRIVER
9.	H0032	SCREW 1/4" - 28 X 1" FLAT HD.
10.	H0059	SHEET METAL SCREW #8 PAN HD. 3/4"
11.	C0013-1	CENTERING PAD & RETAINING CLAMP
12.	H0051	SET SCREW 1/4" - 20 X .5"
13.	H0053	SQUARE KEY
14.	C0014-1	BELT
15.	M0015	PULLEY
16.	H0052	SET SCREW .312 - 18 X .375"
17.	M0004	SPACER
18.	C0011M	BEARING HOUSING
19.	H0044	BOLT .375" - 16 X 2.5"
20.	W0005P	DRIVE SHAFT

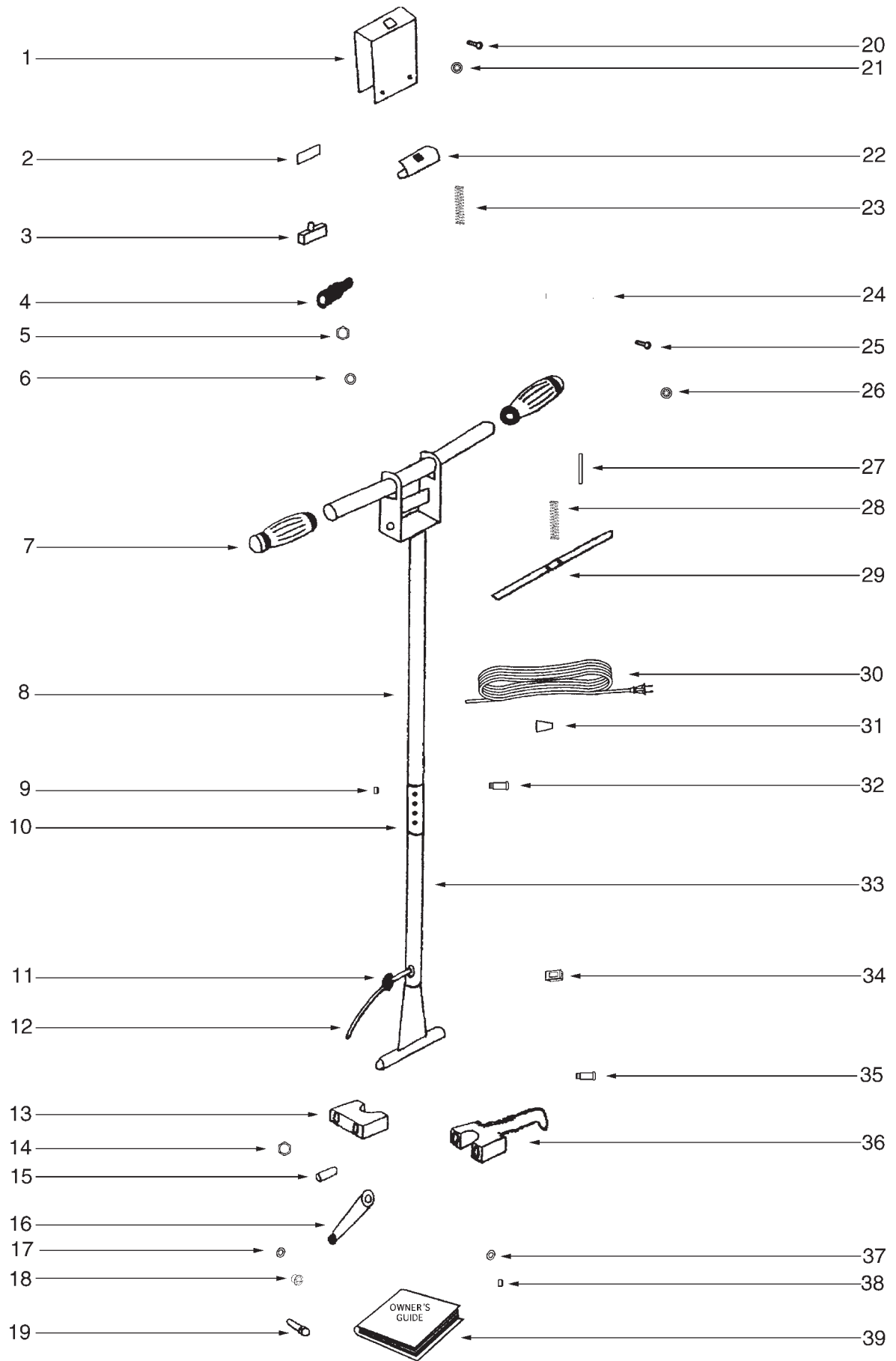

SC6045A

1.	W0003-2P	SWITCHBOX COVER
2.	H0013	SWITCH INSULATION
3.	E0007	SWITCH - ON/OFF
4.	H0021	STRAIN RELIEF
5.	H0022	STRAIN RELIEF NUT
6.	H0022-1	STRAIN RELIEF WASHER
7.	C0007-2	HANDLE GRIP
8.	W0002UP	UPPER HANDLE
9.	H0099	NUT 5/16" - 18
10.	M0027P	HANDLE COUPLING
11.	H0028	GROMMET
12.	E0028	HANDLE CORD
13.	C0006P-1	HANDLE LOCK CLAMP
14.	H0015	NUT 3/8" - 16
15.	H0017	SPADE BOLT
16.	M0001P2	HANDLE LOCK CAM
17.	H0001P	WASHER
18.	H0019	PUSH NUT 5/16"
19.	H0018	RIVET 5/16" X 1.25"
20.	H0040	SCREW 10-24 X .5 PAN HD.
21.	H0020	LOCK WASHER
22.	C0003	SAFETY SWITCH
23.	H0014	SPRING
24.	H0062	POWER CORD CLAMP
25.	H0040	SCREW 10-24 X .5 PAN HD.
26.	H0020	LOCK WASHER
27.	H0012	ROLL PIN
28.	H0023	TRIGGER SPRING
29.	S0008P-1	TRIGGER
30.	E0003G	POWER CORD
31.	H0027	WIRE NUT
32.	H0098	BOLT 5/16" - 18 X 2
33.	W0002LP	LOWER HANDLE
34.	E0006	SWITCH - HI/LO
35.	H0044	BOLT 3/8" - 16 X 2.5
36.	C0008P-1	CORD HOOK
37.	H0016	WASHER 3/8"
38.	H0057	NUT 3/8" - 16
39.	73416	OWNER'S GUIDE