



Model 9004201 – 120V

SPEED EX™

PORTABLE CARPET EXTRACTOR

(S/N 30000000–40000000)

PARTS MANUAL

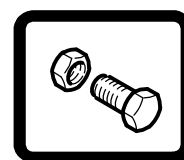
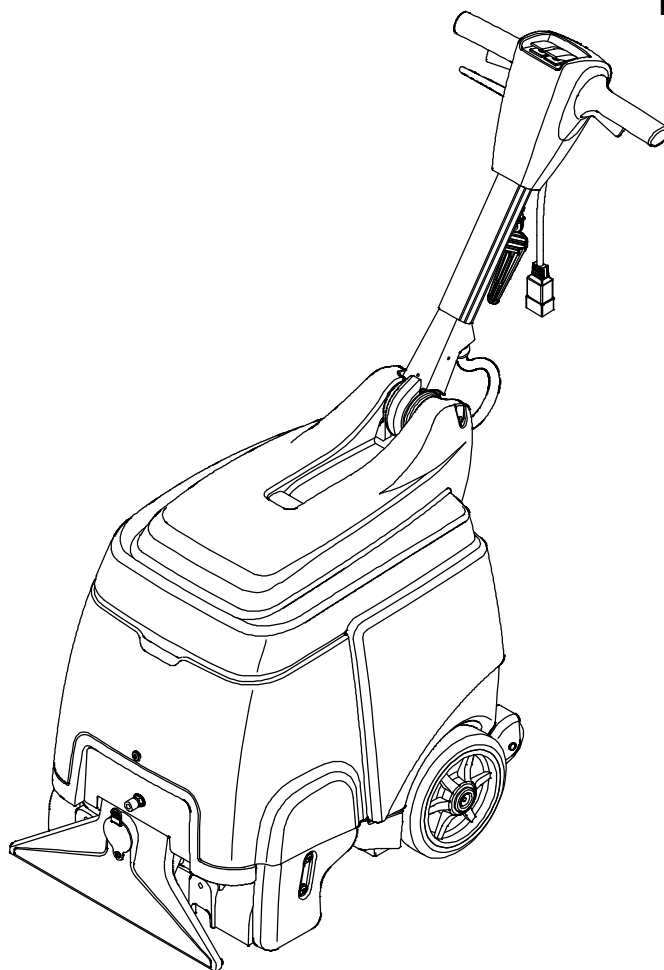

For the latest Parts manuals and other language Operator manuals, visit:

www.nobles.com/manuals

9012806
Rev. 03 (09-2018)



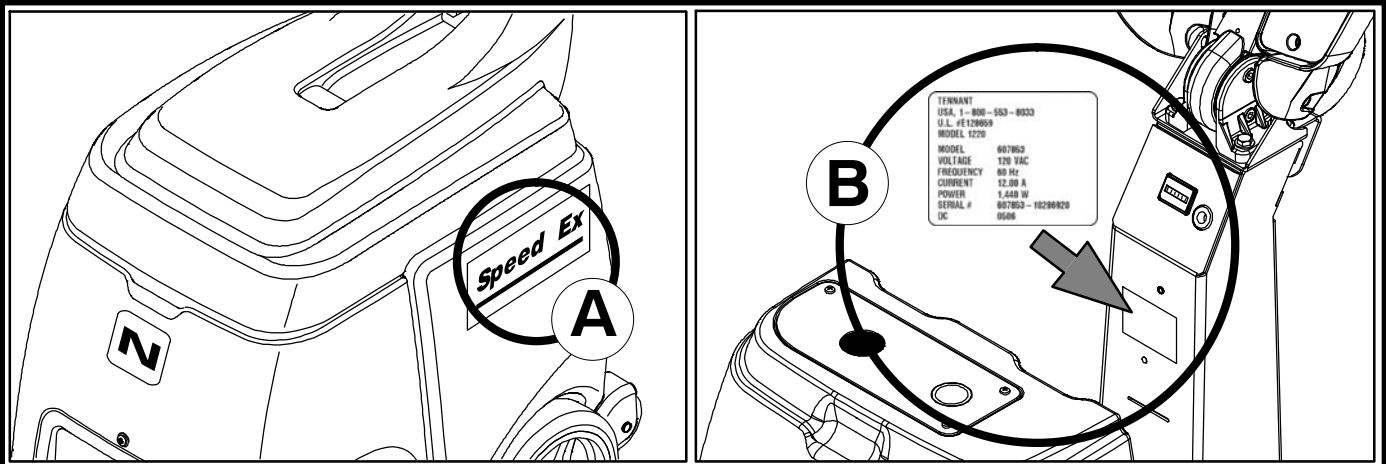

Ref	Part No.	Serial Number	Description	Qty.
1	82681	(000000-)	Bracket Wldt, Lpg Mount	1
▽ 2	63810	(000000-)	Latch Assy, Lpg Tank Mtg, W/Nut	4
▲ 3	51839	(000000-)	Nut Adjustable, Lpg Tank Mtg	2
4	49263	(000000-)	Tie, Cable	3
(D)	82556	(000000-001039)	Bracket, Vaporizer	1
	54930	(000000-)	Vaporizer, LPG	1

HOW TO ORDER PARTS – See diagram above

Only use TENNANT Company supplied or equivalent parts. Parts and supplies may be ordered online, by phone, by fax or by mail.

Follow the steps below to ensure prompt delivery.

1. (A) Identify the machine model.
2. (B) Identify the machine serial number from the data label.
3. (C) Ensure the proper serial number is used from the parts list.
4. Identify the part number and quantity.
Do not order by page or reference numbers.
5. Provide your name, company name, customer ID number, billing and shipping address, phone number and purchase order number.
6. Provide detail shipping instructions.

- (D) ▽ – identifies an assembly
▲ – identifies parts included in assembly

Please fill out at time of installation for future reference.

Model No. – _____

Serial No. – _____

Machine Options – _____

Sales Rep. – _____

Sales Rep. phone no. – _____

Customer ID Number – _____

Installation Date – _____

Tennant Company
PO Box 1452
Minneapolis, MN 55440 USA
Phone: (800) 553-8033
www.nobles.com

TENNANT Cleaning Systems & Equipment (Shanghai) Co., Ltd
Building 1, No. 37777, Caoying Road Qingpu, China 201712
Phone: 86 21 6922 5333
Fax: 86 21 6922 5151
www.tennantco.com.cn

Specifications and parts are subject to change without notice.

Copyright © 2014-2018 TENNANT Company, Printed in China.

RECOMMENDED MAINTENANCE ITEMS

GENERAL RECOMMENDED MAINTENANCE
ITEMS 5

STANDARD PARTS

HANDLE GROUP 6
FRAME GROUP 8
TANKS AND SHROUD GROUP 10
TANK COVER GROUP 12
VACUUM FAN GROUP 14
SOLUTION GROUP 16
SCRUB HEAD GROUP 18
ELECTRICAL DIAGRAM 20

OPTIONS

FLOOR TOOL GROUP, 8 in / 203 mm 22
HAND TOOL GROUP, 4 in / 101 mm 24
PUMP-UP CARPET SPRAYER 25
DOCUMENTATION GROUP 26

RECOMMENDED MAINTENANCE ITEMS

RECOMMENDED MAINTENANCE ITEMS

GENERAL RECOMMENDED MAINTENANCE ITEMS

Part No.	Serial Number	Description	Qty.
1230230	(30000000–40000000)	Wheel, 03.0d 0.88w 0.31b,[Ch]	2
1039073	(30000000–40000000)	Wheel Assy, 8.0d 2.0w 0.5b W/Brg	2
1074694	(30000000–40000000)	Filter, Tube, Soltn, 200mesh	1
1044370	(30000000–40000000)	Ball, Float, W/O Cage	1
1036090	(30000000–40000000)	Seal, Vacuum [Trex]	2
1034801	(30000000–40000000)	Gasket, Tank	2
1028954	(30000000–40000000)	Brush, Scrub, 89mm Od X 386mm Long	1

HANDLE GROUP

355082

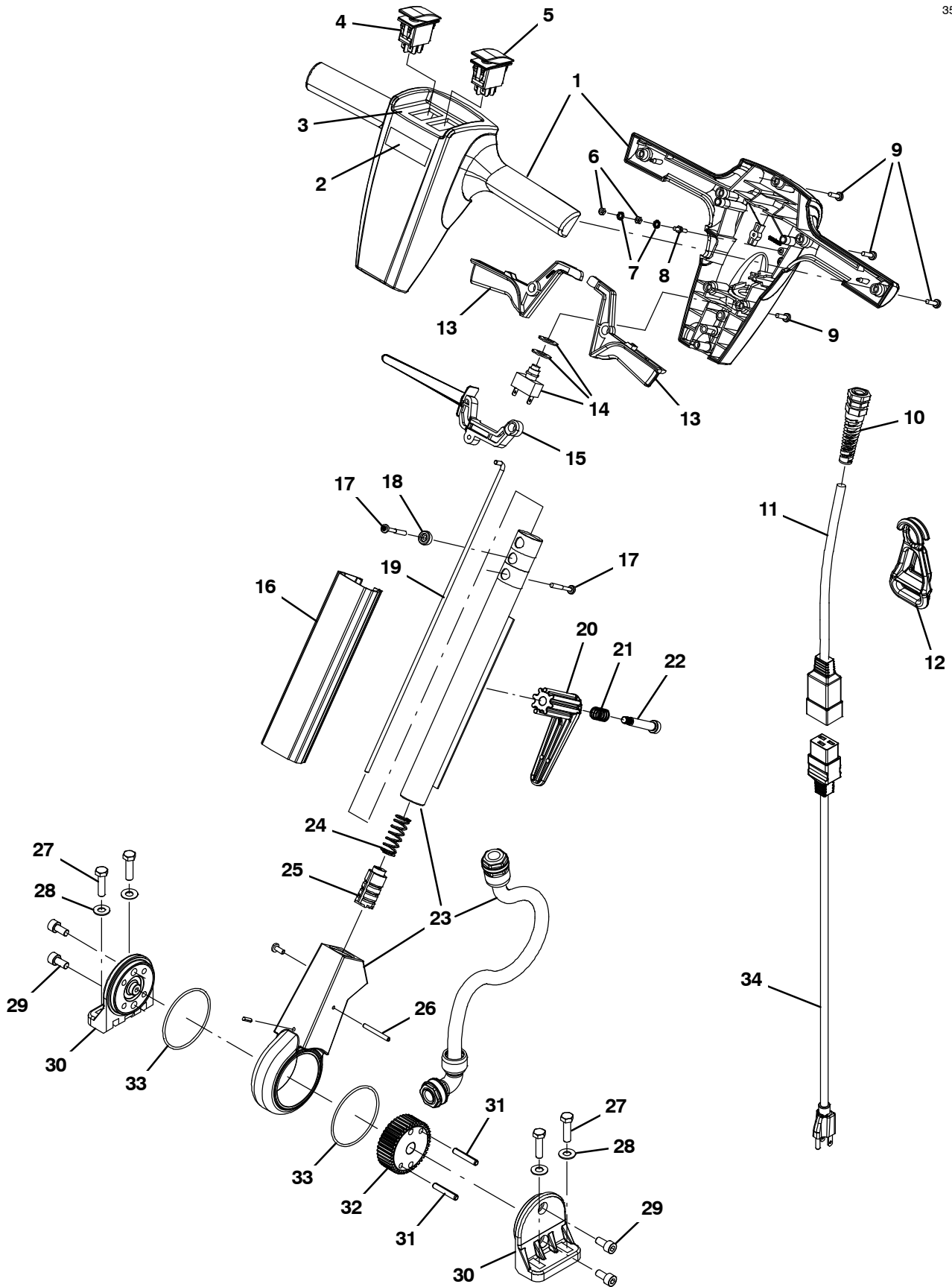

HANDLE GROUP

Ref.	Part No.	Serial Number	Description	Qty.
▽	9005512	(30000000-40000000)	Handle, Nobles Speed Ex 15"	1
▲▽	1 9004322	(30000000-40000000)	Cover, Handle Front/Rear Nobles Se Kit	1
▲▲	2 1039088	(30000000-40000000)	Label, Logo, Handle [Nobles]	1
▲▲	3 1034593	(30000000-40000000)	Label, Opertnl, Instrmt Panl, Extrcr	1
▲	4 609657	(30000000-40000000)	Switch, Rocker, On / Off / On	1
▲	5 602919	(30000000-40000000)	Switch, Rocker, Dpdt, On / On	1
▲	6 42368	(30000000-40000000)	Nut, Hex, Std, M4 X 0.70, 8	2
▲	7 140061	(30000000-40000000)	Washer, Lock, Ext, 08, Pl	2
▲	8 1034952	(30000000-40000000)	Screw, Hex, M4 X 0.7 X 12, Dbl Thrd	1
▲	9 1043573	(30000000-40000000)	Screw, #10-14 X 0.675, Spl[Shcs,Selftap]	7
▲	10 130166	(30000000-40000000)	Grip, Cord, Strainrelief Pg-11 W/Nut Bk	1
▲	11 1042410	(30000000-40000000)	Cord, 14ga /3, 16.0l, W/ Receptacle, Yel	1
▲	12 130176	(30072485-40000000)	Clip, Cord, Strainrelief [Belt] (Yellow)	1
▲	12 1037147	(30000000-30072484)	Clip, Cord, Strainrelief, Black	1
▲	13 1033893	(30000000-40000000)	Lever, Cntrl, Switch [Trex]	2
▲	14 9008568	(30000000-40000000)	Switch Kit, W/ Washers, Fr/ F/1063165	1
▲	15 1034945	(30000000-40000000)	Lever, Adjmt, Handle	1
▲	16 1034181	(30072159-20000000)	Cover, Handle, Gray	1
▲	16 1036599	(30000000-30072158)	Cover, Handle, Nobles [Trex]	1
▲	17 1043572	(30000000-40000000)	Screw, #10-14 X 0.15, Spl[Shcs Selftap]	2
▲	18 1034176	(30000000-40000000)	Bushing, Flng, 5mmb 12mmd 8mml, Pa6	1
▲	19 1034180	(30000000-40000000)	Rod, Release [Trex]	1
▲	20 603104	(30000000-40000000)	Hook, Cord, Blk [Quick-Release]	1
▲	21 603108	(30000000-40000000)	Spring, Cmpr, Switch	1
▲	22 140239	(30000000-40000000)	Bolt, Shld, .38d X 1.75, .31-18	1
▲	23 1045239	(30000000-40000000)	Tube, Assy, Handle [W/Harnesses]	1
▲	24 1013295	(30000000-40000000)	Spring, Cmpr [2100 Series]	1
▲	25 9006059	(30000000-40000000)	Plunger Kit, Handle	1
▲	26 1034924	(30000000-40000000)	Pin, Roll, 04mmd X 40mml	1
▲	27 1016399	(30000000-40000000)	Screw, Hex, M8 X 1.25 X 30, NI, Ss	4
▲	28 140027	(30000000-40000000)	Washer, Flat, 0.35b 0.75d .04, Ss	4
▲	29 49609	(30000000-40000000)	Screw, Soc, M8 X 1.25 X 16, 12.9	4
▲	30 1000307	(30000000-40000000)	Handle, Pivot, Half	2
▲	31 1034155	(30000000-40000000)	Pin, Roll, 06mmd X 36mml	2
▲	32 1034872	(30000000-40000000)	Gear, Lock, Handle	1
▲	33 612422	(30000000-40000000)	Seal, Org, Gear Seat	2
▲	34 1042403	(30000000-40000000)	Cord, Power, 1.5mm /3 Yel[2x15m 50ft Us]	1

▽ ASSEMBLY

▲ INCLUDED IN ASSEMBLY

FRAME GROUP

355266

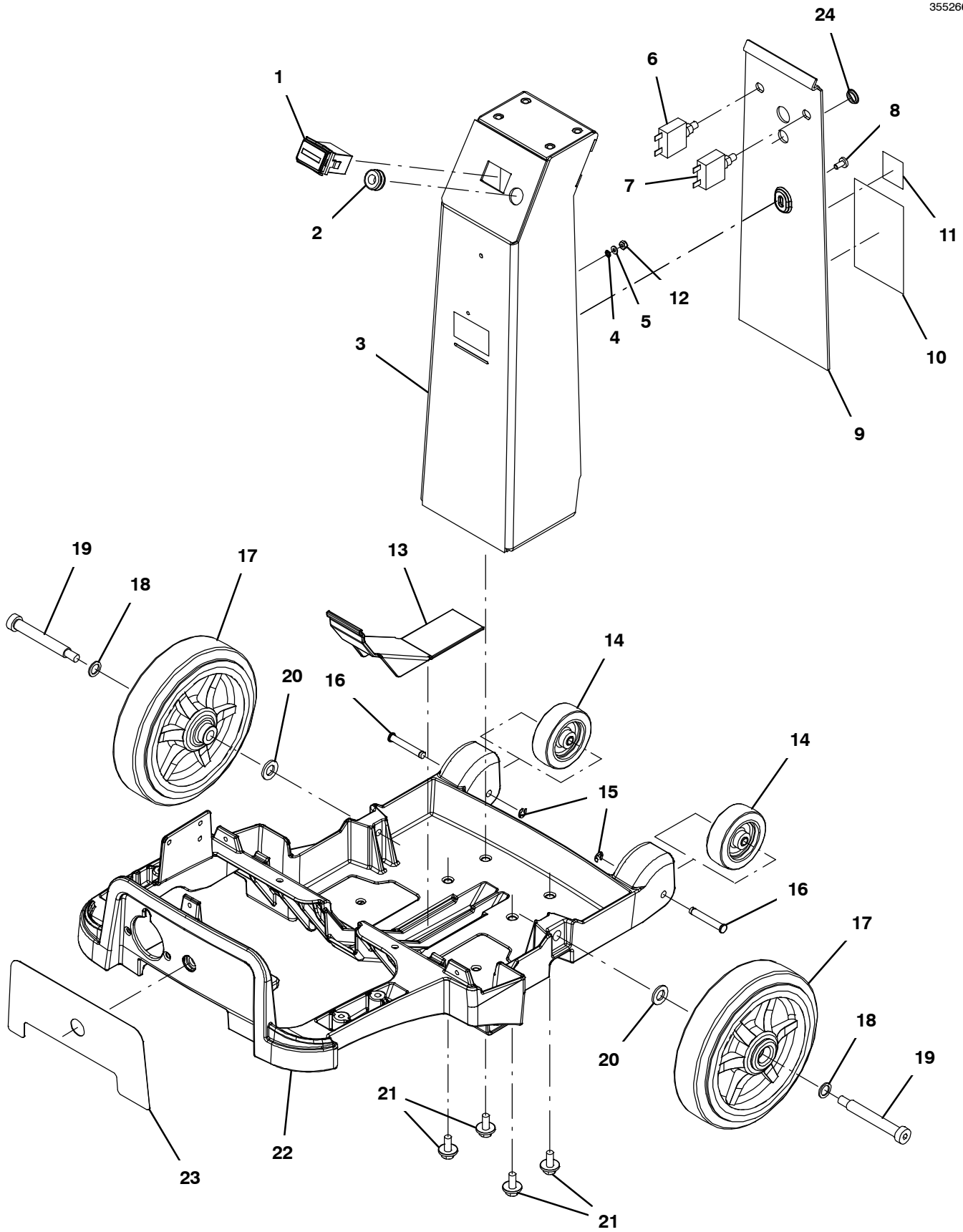

FRAME GROUP

Ref.	Part No.	Serial Number	Description	Qty.	
1	1064038	(30000000-40000000)	Gauge, Hourmeter, 05-277 Volt, Ac / Dc	1	
2	86726	(30000000-40000000)	Grommet, Rbr, 0.44id, F/0.5h, .19 Matl	1	
3	9004274	(30000000-40000000)	Column Kit, W/ Label [5 Gal]	1	
4	02938	(30000000-40000000)	Washer, Lock, Int, 08, Ss	1	
5	41578	(30000000-40000000)	Washer, Flat, 06, Ss	1	
6	383720	(30000000-40000000)	Circuitbreaker, 05.0a, Resetable	1	
7	383722	(30000000-40000000)	Circuitbreaker, 15.0a, Resetable	1	
8	1043600	(30000000-40000000)	Filter, Pump, 250 Vac, 3a, 50/60hz	1	
▽	9	9004275	(30000000-40000000)	Cover Kit, Column , W/ Label [5gal 120v]	1
▲	10	1039105	(30000000-40000000)	Label,Warning,Ac Scrbr/Extr [En/Fr/Es/Jp]	1
▲	11	NA	(30000000-40000000)	Label, Safety, 120vac [Etl]	1
	12	1044427	(30000000-40000000)	Nut, Hex, Lock, #8-32, NI, Ss	1
	13	1031418	(30000000-40000000)	Cover, Frame, Rear [Trex]	1
	14	1230230	(30000000-40000000)	Wheel, 03.0d 0.88w 0.31b,[Ch]	2
	15	1035139	(30000000-40000000)	Ring, Retaining, Ext, 0.31d, E-Type	2
	16	1035137	(30000000-40000000)	Pin, Clevis, Grvd 0.31d X 2.00l, Ss	2
	17	1039073	(30000000-40000000)	Wheel Assy, 8.0d 2.0w 0.5b W/Brg	2
	18	1038770	(30000000-40000000)	Washer, Flat, 0.50b 0.75d 0.06, Ss	2
	19	1033757	(30000000-40000000)	Bolt, Shld, .50 X 3.25, .38-16, Ss	2
	20	33925	(30000000-40000000)	Washer, Flat, M12, Ss	2
	21	1020341	(30000000-40000000)	Screw, Hex, M8 X 1.25 X 20, Ss, Sems	4
▽	22	9004297	(30000000-40000000)	Frame, W/ Front Decal Kit Nobles	1
▲	23	1038092	(30000000-40000000)	Label, Extractor, Nobles	1
	24	57167	(30000000-40000000)	Plug, Hole, Rnd, 0.62h .03-.12, Blk Nyl (Non-Telemetry Models)	1
	N/S	1033925	(30000000-40000000)	Harness, Chassis, Ele [T-Rex Extractor]	1

▽ ASSEMBLY

▲ INCLUDED IN ASSEMBLY

N/S = NOT SHOWN

TANKS AND SHROUD GROUP

355075

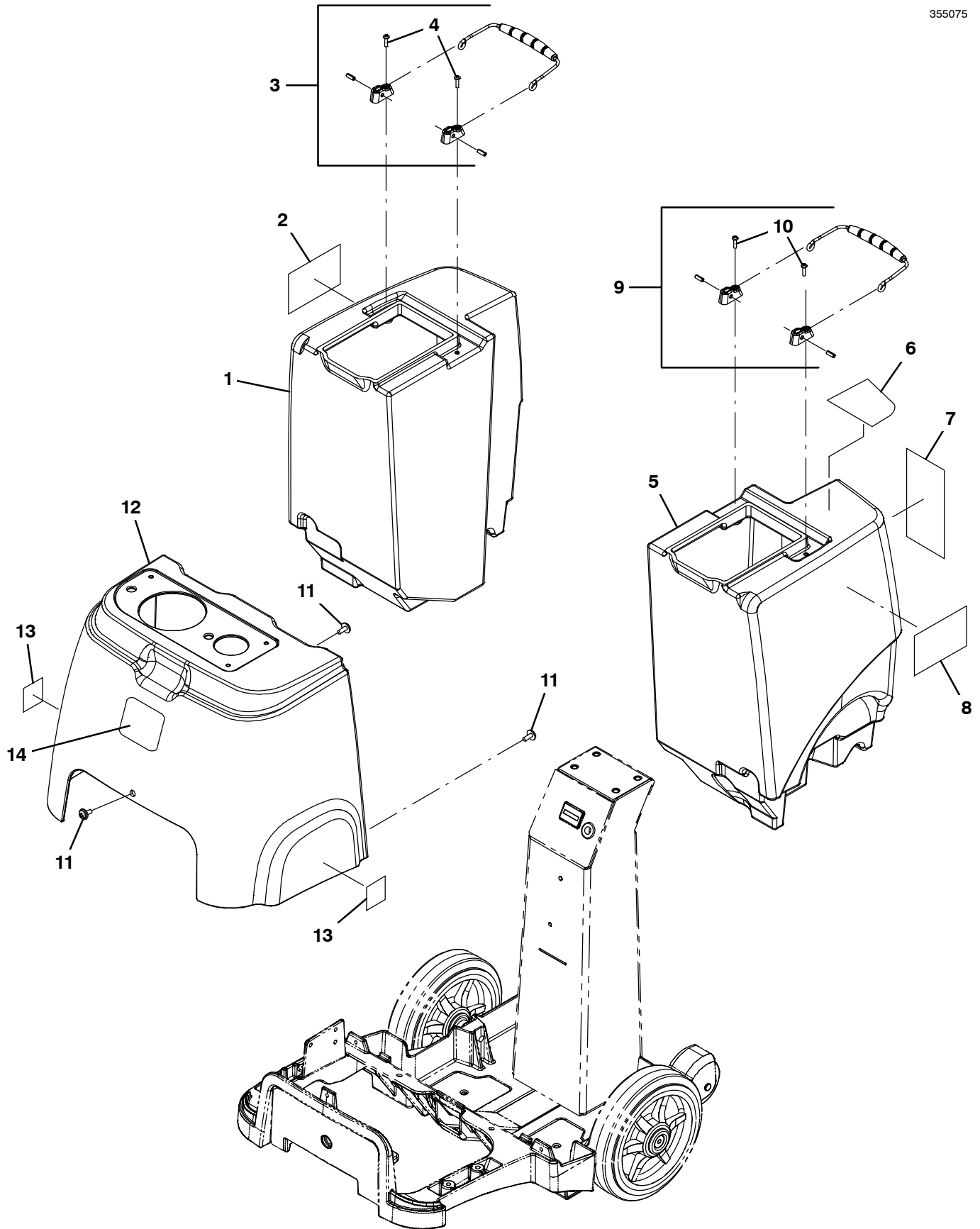

TANKS AND SHROUD GROUP

Ref.	Part No.	Serial Number	Description	Qty.
▽	1	9016192	(30072199-40000000) Tank Kit, Recvy W/Labels [Nob Gray 5gal]	1
▽	1	9004309	(30000000-30072198) Tank, Rec W/ Labels Nobles 5 Gal Kit	1
▲	2	1039500	(30000000-40000000) Label, Side, Extractor	1
▲▽	3	9004285	(30000000-40000000) Handle, Tank Kit	1
▲▲	4	24265	(30000000-40000000) Screw, Pan, Phl, M4 X 0.70 X 16, Ss	2
▽	5	9016193	(30072199-40000000) Tank Kit, Soltn W/Labels [Nob Gray 5gal]	1
▽	5	9004311	(30000000-30072198) Tank, Soltn W/ Labels Nobles 5 Gal Kit	1
▲	6	1038968	(30000000-40000000) Label, Soltn, Tank [5.0 Gal]	1
▲	7	1040114	(30000000-40000000) Label, Oper, Instr [Extractor]	1
▲	8	1039500	(30000000-40000000) Label, Side, Extractor	1
▲▽	9	9004285	(30000000-40000000) Handle, Tank Kit	1
▲▲	10	24265	(30000000-40000000) Screw, Pan, Phl, M4 X 0.70 X 16, Ss	2
	11	1019349	(30000000-40000000) Screw, Trs, M6 X 1.00 X 16, Ss, Sems	3
▽	12	9004300	(30000000-40000000) Shroud, W/ Labels Nobles 5 Gal Kit	1
▲	13	578769	(30000000-40000000) Decal, Moving Parts Textless	2
▲	14	1034636	(30000000-40000000) Label, Front, 3.00 [Nobles Icon]	1

▽ ASSEMBLY

▲ INCLUDED IN ASSEMBLY

TANK COVER GROUP

355047

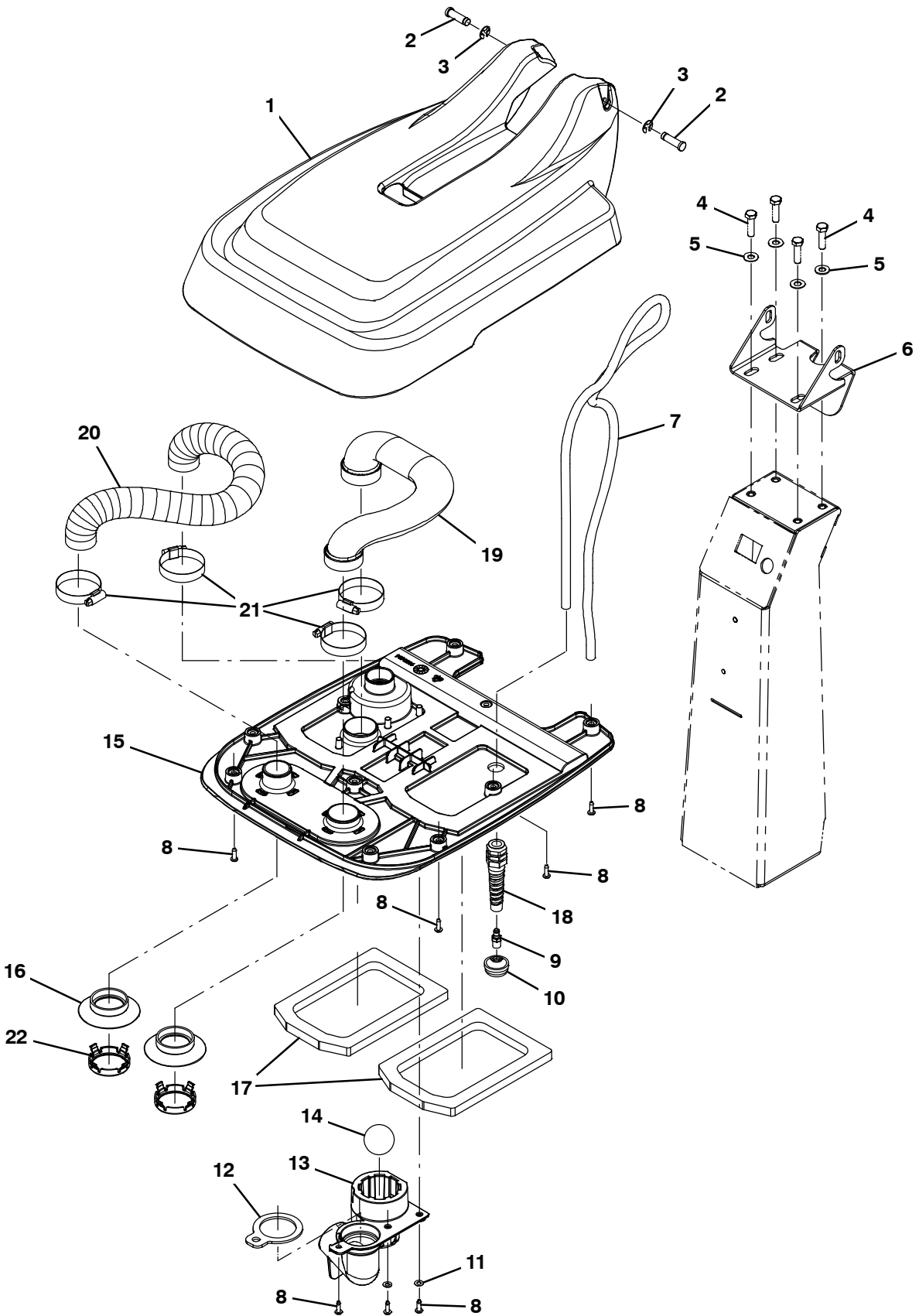

TANK COVER GROUP

Ref.	Part No.	Serial Number	Description	Qty.	
1	1037759	(30000000-40000000)	Cover , Tanks, Upper, Nobles [Trex]	1	
2	1035358	(30000000-40000000)	Pin, Grvd, 0.375d, 1.25l	2	
3	24555	(30000000-40000000)	Ring, Retaining, Ext, 0.38d, [E-Ring]	2	
4	1016399	(30000000-40000000)	Screw, Hex, M8 X 1.25 X 30, NI, Ss	4	
5	140027	(30000000-40000000)	Washer, Flat, 0.35b 0.75d .04, Ss	4	
6	1034346	(30000000-40000000)	Bracket, Pivot, Cover, Mtg	1	
7	1036063	(30000000-40000000)	Hose, Soltn, .25 Id, .453 Od, 56.0 L	1	
8	140340	(30000000-40000000)	Screw, Pan, Phl, 10-24 X 0.62, Ss[Typ25]	13	
9	1042715	(30000000-40000000)	Fitting, Brs, Str, Bm04/Pm02	1	
10	1074694	(30000000-40000000)	Filter, Tube, Soltn, 200mesh	1	
11	140011	(30000000-40000000)	Washer, Flat, 0.21b 0.45d .03, Ss	2	
12	1051274	(30000000-40000000)	Gasket, Shield, Float	1	
13	1042277	(30000000-40000000)	Shield, Float	1	
14	1044370	(30000000-40000000)	Ball, Float, W/O Cage	1	
▽	15	9005924	(30000000-40000000)	Cover, Tank, Inner W/ Seals, Kit	1
▲	16	1036090	(30000000-40000000)	Seal, Vacuum [Trex]	2
▲	17	1034801	(30000000-40000000)	Gasket, Tank	2
▲	18	602849	(30000000-40000000)	Strainrelief, Cord, Ele, Pm08, Blk Nyl	1
	19	1035866	(30000000-40000000)	Hose, Recvy, Formed [Trex]	1
	20	1037756	(30000000-40000000)	Hose, Vacuum, 1.5od, 18.0l [Wire-Reinf]	1
	21	140308	(30000000-40000000)	Clamp, Hose, Wormdrive, 1.31-2.25d, .50w	4
	22	1054345	(30000000-40000000)	Clip, Retaining, Seal	2

▽ ASSEMBLY

▲ INCLUDED IN ASSEMBLY

VACUUM FAN GROUP

355050

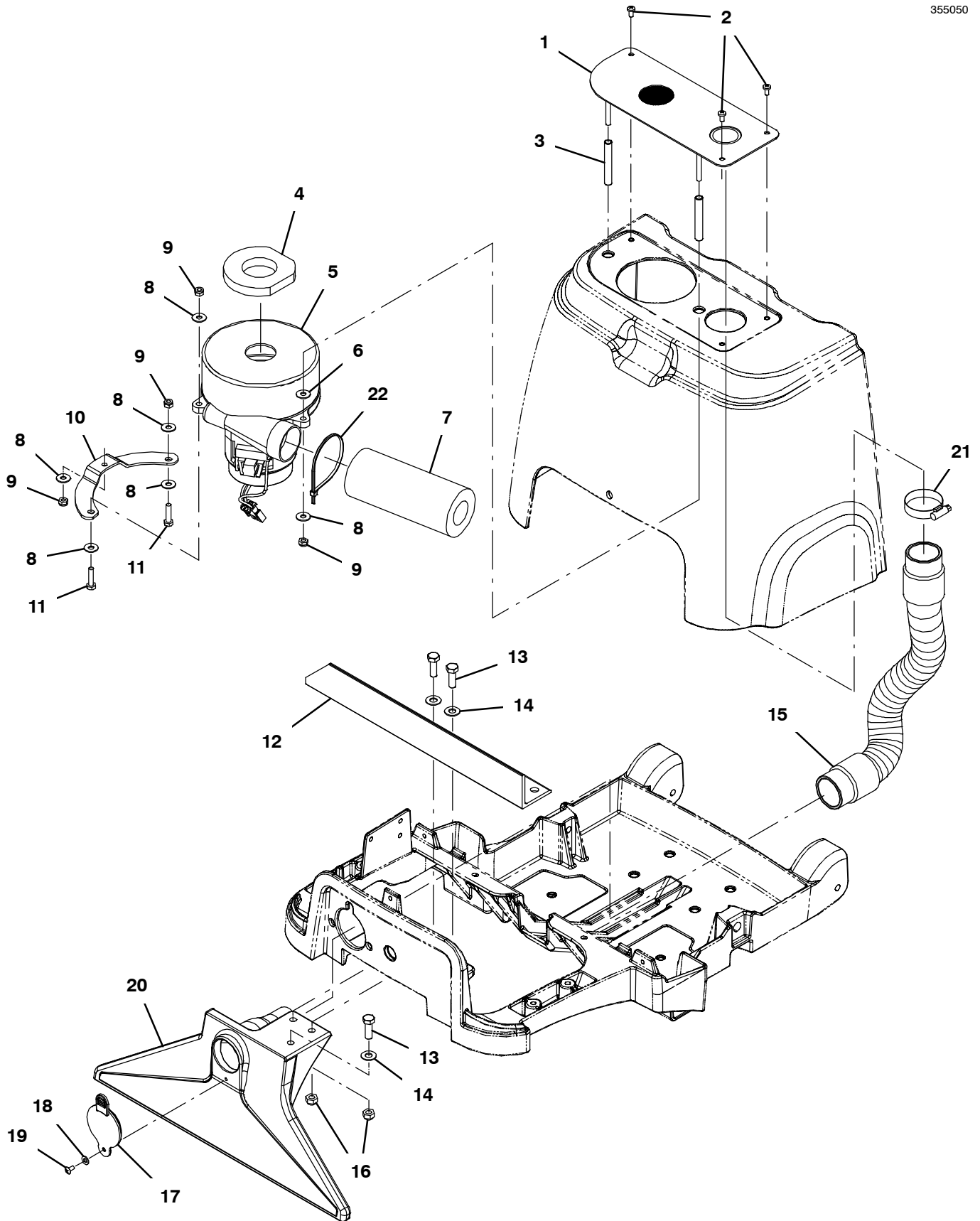

VACUUM FAN GROUP

Ref.	Part No.	Serial Number	Description	Qty.
1	1031960	(30000000-40000000)	Plate, Mtg, Vacuum	1
2	1026454	(30000000-40000000)	Screw, Pan, Phl, M5 X 0.80 X 10, Ss	3
3	610144	(30000000-40000000)	Spacer, Fan	2
4	630010	(30000000-40000000)	Gasket, 12.7mm Th, 43mmid 73mmod	1
▽	5	9012566	(30000000-40000000) Fan Kit, Vacuum, 5.7d, 120vac, 2 Stage	1
▲		1071842	(30000000-40000000) Vr, Brush Kit, Vac Fan 1071839	1
▲	6	01684	(30000000-40000000) Washer, Flat, 0.27b 0.69d .05, Ss	1
7	600009	(30000000-40000000)	Muffler, Exhaust, Vacfan	1
8	01684	(30000000-40000000)	Washer, Flat, 0.27b 0.69d .05, Ss	6
9	08708	(30000000-40000000)	Nut, Hex, Lock, M6 X 1.00, NI	4
10	1034069	(30000000-40000000)	Plate, Vac Mounting	1
11	09007	(30000000-40000000)	Screw, Hex, M6 X 1.00 X 25, Ss	2
12	1045263	(30000000-40000000)	Brace, Frame	1
13	1015852	(30000000-40000000)	Screw, Hex, M8 X 1.25 X 25, NI, Fl, Ss	3
14	140027	(30000000-40000000)	Washer, Flat, 0.35b 0.75d .04, Ss	3
15	1032555	(30000000-40000000)	Hose, Vacuum, 1.50id X 19.5l, 2cuff, Clr	1
16	08713	(30000000-40000000)	Nut, Hex, Lock, M8 X 1.25, NI, Ss	3
17	607183	(30000000-40000000)	Seal, Cap, Vacuum Tool [607170]	1
18	140011	(30000000-40000000)	Washer, Flat, 0.21b 0.45d .03, Ss	1
19	140801	(30000000-40000000)	Screw, Trs, Phl, 08-32 X 0.38, Ss	1
20	1035555	(30000000-40000000)	Tool, Floor [Machined]	1
21	11531	(30000000-40000000)	Clamp, Hose, Wormdrive, 1.06-2.00d, .56w	1
22	130773	(30000000-40000000)	Tie, Cable, Nyl, 11.0l, .14w, 3.0 Max. D	1

▽ ASSEMBLY

▲ INCLUDED IN ASSEMBLY

SOLUTION GROUP

355049

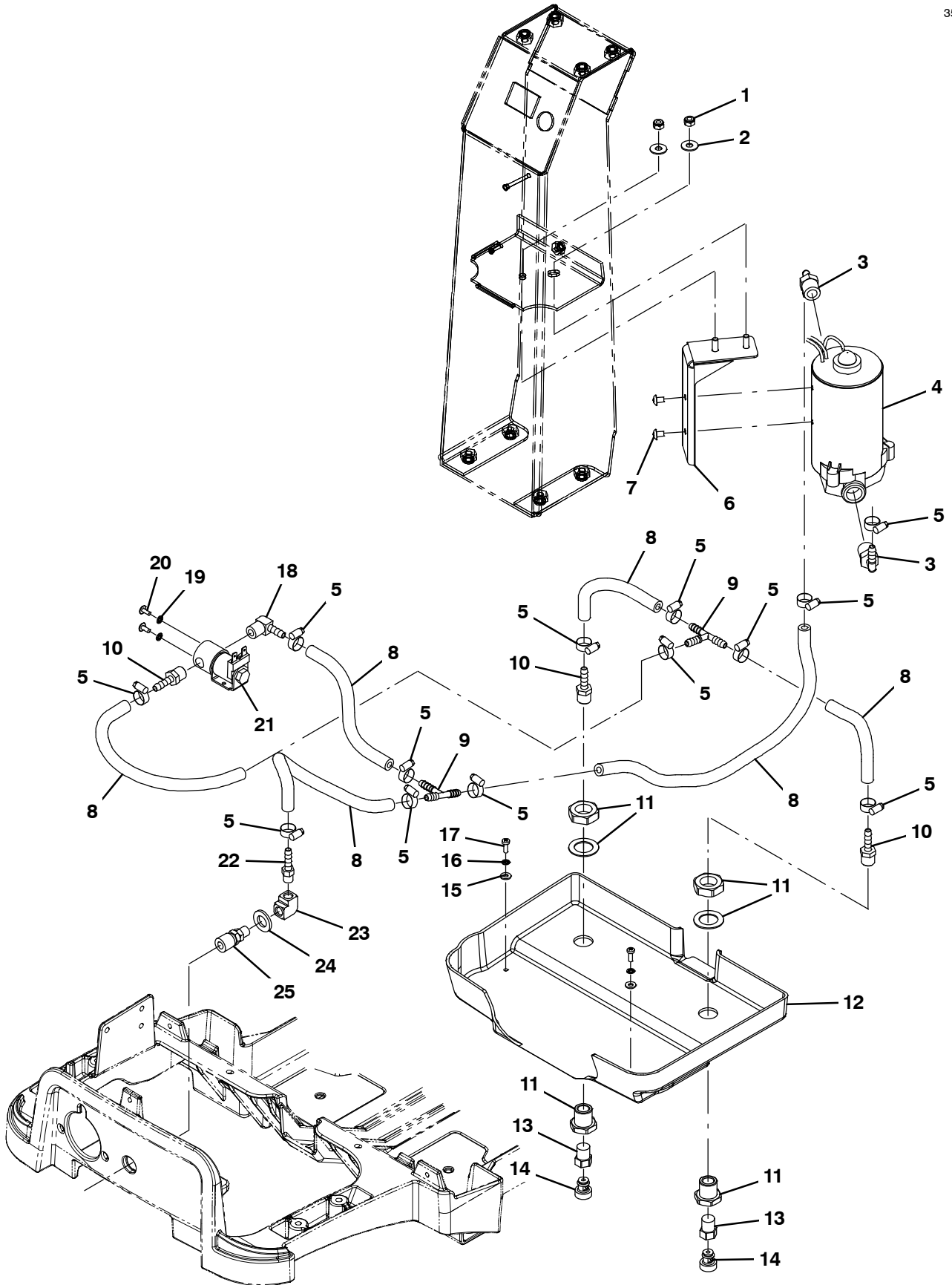

SOLUTION GROUP

Ref.	Part No.	Serial Number	Description	Qty.
1	08712	(30000000-40000000)	Nut, Hex, Lock, M6 X 1.00, NI, Ss	2
2	01684	(30000000-40000000)	Washer, Flat, 0.27b 0.69d .05, Ss	2
3	150417	(30000000-40000000)	Fitting, Plstc, E90, Bm04/Pm06	2
4	1031915	(30000000-40000000)	Pump, Soltn, Ele, 110vac	1
5	43844	(30000000-40000000)	Clamp, Hose, Wormdrive, 0.25-0.62d, .31w	13
6	1034331	(30000000-40000000)	Bracket, Pump	1
7	140751	(30000000-40000000)	Screw, Hex, 10-32 X 0.50, PI	2
8	606364	(30000000-40000000)	Hose, Pvc, Brd, 0.25id 0.50od 60.0l, Gray (160204)	1
9	150713	(30000000-40000000)	Fitting, Plstc, Tee, Bm04/Bm04/Bm04	2
10	150515	(30000000-40000000)	Fitting, Brs, Str, Bm04/Pm04 [Taped]	2
11	78122	(30000000-40000000)	Fitting, Brs, Str, Pf04/Pf04, Bh	2
12	1037350	(30000000-40000000)	Shroud, Nozzle [Extractor]	1
13	1034582	(30000000-40000000)	Nozzle Adapter, Qppm	2
14	1037338	(30000000-40000000)	Nozzle, Qmfv 110-06	2
15	41579	(30000000-40000000)	Washer, Flat, 08, Ss	2
16	02938	(30000000-40000000)	Washer, Lock, Int, 08, Ss	2
17	579237	(30000000-40000000)	Screw, Pan, Phl, M4 X 0.70 X 12, Ss	2
18	150418	(30000000-40000000)	Fitting, Brs, E90, Bm04/Pm04	1
19	02938	(30000000-40000000)	Washer, Lock, Int, 08, Ss	2
20	140801	(30000000-40000000)	Screw, Trs, Phl, 08-32 X 0.38, Ss	2
21	210033	(30000000-40000000)	Valve, Water, Solenoid, 120vac Pf04/Pf04	1
22	150525	(30000000-40000000)	Fitting, Brs, Str, Bm04/Pm02	1
23	150402	(30000000-40000000)	Fitting, Brs, E90, Pf02/Pf02	1
24	3148.816	(30000000-40000000)	Washer, Flat, 0.52b 0.88d .06, Stl, PI	1
25	150915	(30000000-40000000)	Fitting, Brs, Qdc, Pm02, Fem [Ser 5]	1

SCRUB HEAD GROUP

355268

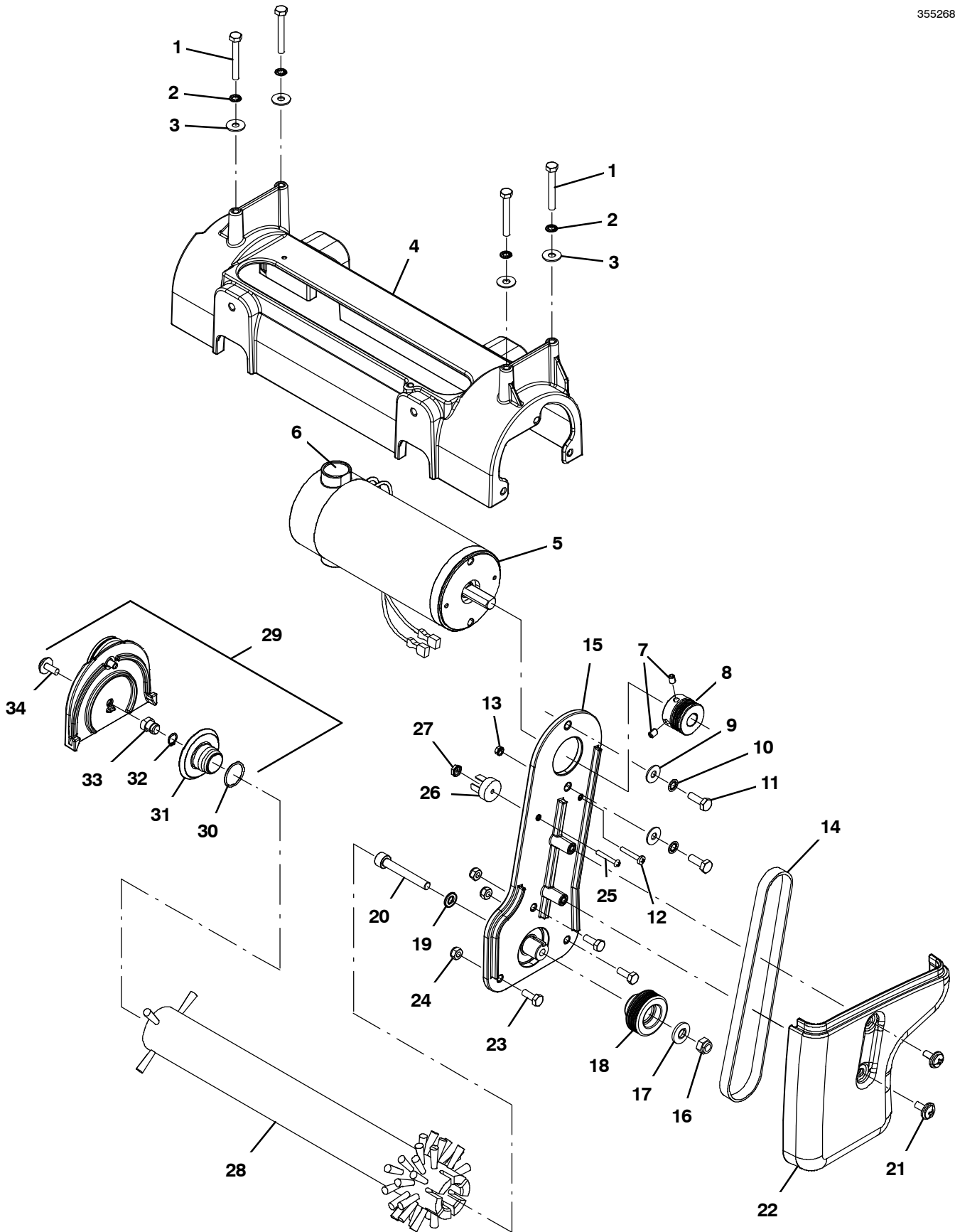

SCRUB HEAD GROUP

Ref.	Part No.	Serial Number	Description	Qty.
	1	1045325	(30000000-40000000) Screw, Hex, M6 X 1.00 X 45, Ss	4
	2	1027144	(30000000-40000000) Washer, Lock, Int, M6, Ss	4
	3	01684	(30000000-40000000) Washer, Flat, 0.27b 0.69d .05, Ss	4
	4	1034380	(30000000-40000000) Housing, Brush, Sngl, 40cm	1
▽	5	1072719	(30000000-40000000) Motor, Ele, 115vdc 2200rpm .33hp	1
▲	6	1067897	(30000000-40000000) Vr, Brush Kit, Motor	2
	7	09162	(30000000-40000000) Screw, Set, Soc, M6 X 1.00 X 8, NI	2
	8	1030620	(30000000-40000000) Sheave, 07grv, 32.78pd [Ph]	1
	9	01684	(30000000-40000000) Washer, Flat, 0.27b 0.69d .05, Ss	2
	10	07515	(30000000-40000000) Washer, Lock, Int, 0.25, Ss	2
	11	34323	(30000000-40000000) Screw, Hex, .25-20 X 0.75, NI	2
	12	1033197	(30000000-40000000) Screw, Pan, Phl, M4 X 0.70 X 25, Ss	1
	13	1007109	(30000000-40000000) Nut, Hex, Lock, M4 X 0.70, Kep, Ext	1
	14	9004283	(30000000-40000000) Belt Kit, W/ Installation Tool	1
▽	15	9004281	(30000000-40000000) Bracket, Motor Mount W/ Bearing/Seal Kit (Includes Hub, Key, Bearing and Seal)	1
▲	16	08713	(30000000-40000000) Nut, Hex, Lock, M8 X 1.25, NI, Ss	1
▲	17	41186	(30000000-40000000) Washer, Flat, Belleville, .31	1
▲	18	1030614	(30000000-40000000) Sheave, 07grv, 42.3pd [Ph]	1
▲	19	1057482	(30000000-40000000) Washer, Flat, 0.328b 0.571d 0.063, Ss	1
▲	20	1057476	(30000000-40000000) Screw, Soc, M8 X 1.25 X 55, Ss	1
	21	1019349	(30000000-40000000) Screw, Trs, M6 X 1.00 X 16, Ss, Sems	2
	22	1064397	(30000000-40000000) Cover, Belt, Spg (Single Roller)	1
	23	15678	(30000000-40000000) Screw, Hex, M6 X 1.00 X 16, Ss	3
	24	08712	(30000000-40000000) Nut, Hex, Lock, M6 X 1.00, NI, Ss	3
	25	140946	(30000000-40000000) Screw, Rnd, Slt, 06-32 X 1.00, Nyl	1
	26	130288	(30000000-40000000) Rectifier, Bridge, Rnd, 12a 1000volt, Ce	1
	27	140534	(30000000-40000000) Nut, Hex, #06-32, Nyl	1
	28	1028954	(30000000-40000000) Brush, Scrub, 89mm Od X 386mm Long	1
▽	29	9007962	(30000000-40000000) Door Kit, Brush, W/ Hdwr	1
▲	30	1042312	(30000000-40000000) Seal, Org, .070 X .875 Id, 020	1
▲	31	1030680	(30000000-40000000) Hub, Idler, Brush	1
▲	32	01543	(30000000-40000000) Ring, Retaining, Ext, 0.39d, Basic	1
▲	33	1030682	(30000000-40000000) Shaft, Idler Plug	1
▲	34	1019349	(30000000-40000000) Screw, Trs, M6 X 1.00 X 16, Ss, Sems	1

▽ ASSEMBLY

▲ INCLUDED IN ASSEMBLY

ELECTRICAL DIAGRAM

1046070_E

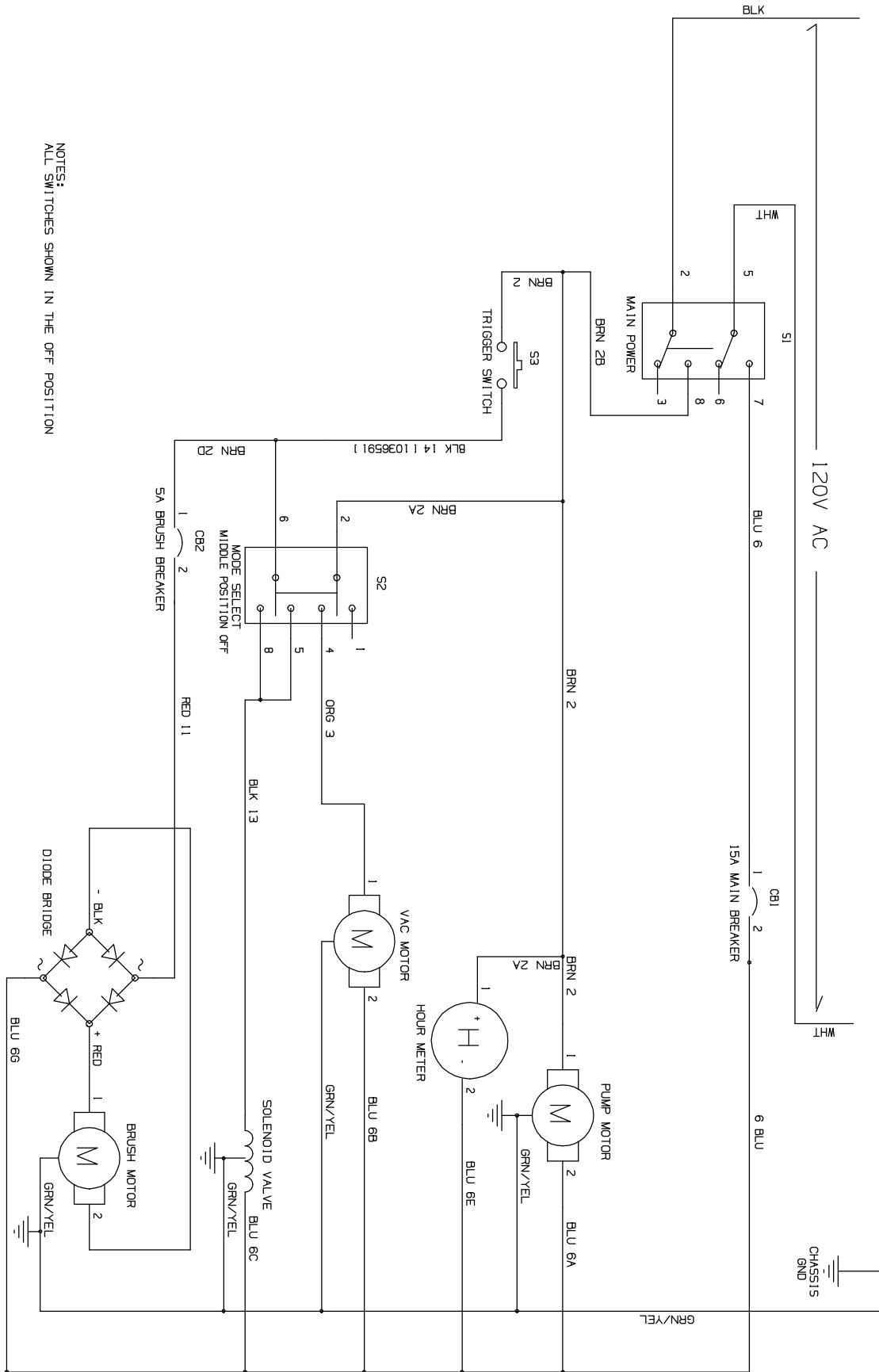

NOTES:
ALL SWITCHES SHOWN IN THE OFF POSITION

FLOOR TOOL GROUP, 8 in / 203 mm

355116

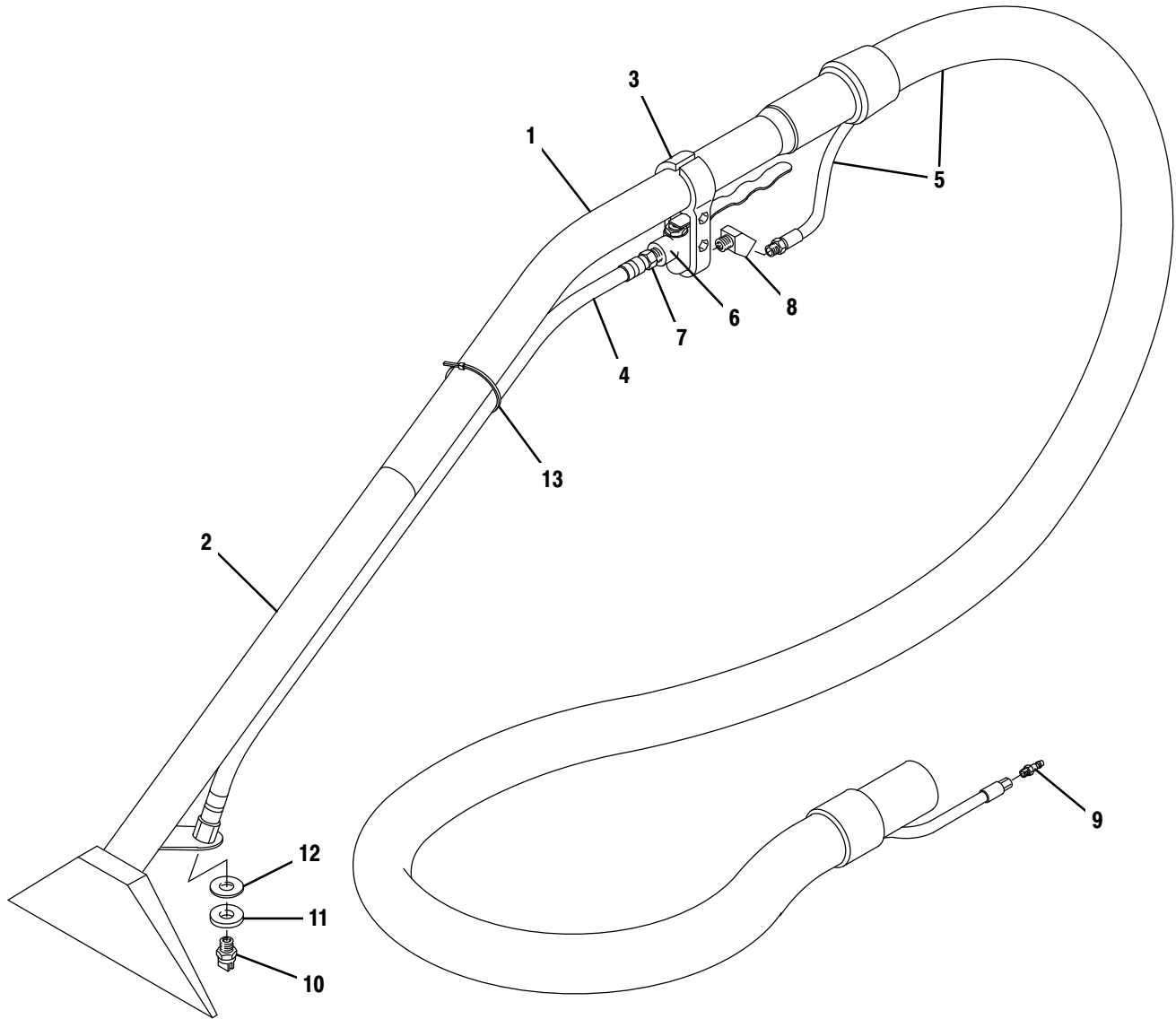

FLOOR TOOL GROUP, 8 in / 203 mm

Ref.	Part No.	Serial Number	Description	Qty.
▽	1058735	(30000000–40000000)	Tool Assy, Floor, W/ Ss Head	1
▲	1 1058997	(30000000–40000000)	Wand, Tube, Upper, Fr/ 1058735, Replmt	1
▲	2 1058995	(30000000–40000000)	Wand Assy, Lower, Fr/ 1058735, Replmt	1
▲	3 605988	(30000000–40000000)	Vr, Bracket, Hanger, Valve	1
▲	4 1058998	(30000000–40000000)	Hose, Brd, 39.0l, Fr/ 1058735, Replmt	1
▲	5 1059131	(30000000–40000000)	Hose Assy, 10ft, F/1058735, Replmt	1
▲	6 578064000	(30000000–40000000)	Valve, Water, Flow Cntrl, W/Lever [Wand]	1
▲	7 150516	(30000000–40000000)	Fitting, Brs, Str, Bm06/Pm04	1
▲	8 150403	(30000000–40000000)	Fitting, Brs, E45, Pf04/Pm04 [Taped]	1
▲	9 150921	(30000000–40000000)	Fitting, Ss, Qdc, Pm02 [Ser 5]	1
▲	10 1059002	(30000000–40000000)	Fitting, Jet, Vee, .25npt, Brs	1
▲	11 1058999	(30000000–40000000)	Washer, Flat, Abs, F/ 1058735, Replmt	1
▲	12 140058	(30000000–40000000)	Washer, Flat, 0.54b 0.88d .06, Ss [Wand]	1
▲	13 130041	(30000000–40000000)	Tie, Cable, Nyl, 11.5l .19w	1
	N/S 220040	(30000000–40000000)	Bag, Hose, Accssry, 24x36[W/Draw String] (Optional)	1

▽ ASSEMBLY

▲ INCLUDED IN ASSEMBLY

HAND TOOL GROUP, 4 in / 101 mm

355117

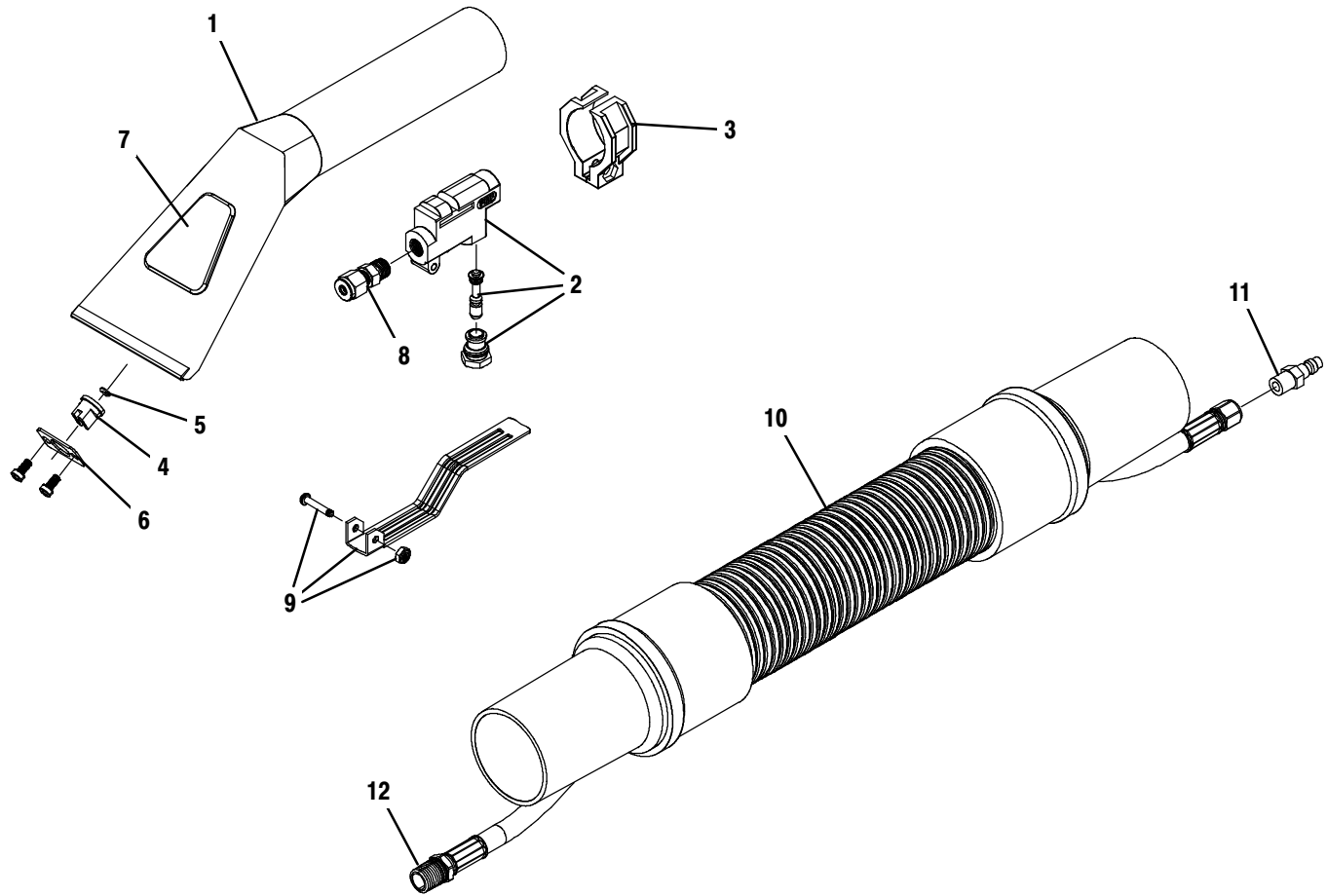

Ref.	Part No.	Serial Number	Description	Qty.
	1058747	(30000000-40000000)	Tool Assy, Hand, W/ Ss Head & Plstc Wndw	1
▽	1059230	(30000000-40000000)	Tool Assy, W/Trigger F/1058747, Replmt	1
▲	1 1059003	(30000000-40000000)	Tool, W/ Wndw, Ss, F/1058747, Replmt	1
▲	2 611807	(30000000-40000000)	Valve, Tool, Hand [Pmf]	1
▲	3 611812	(30000000-40000000)	Valve, Hanger [Pmf]	1
▲	4 1059006	(30000000-40000000)	Fitting, Jet, Tee, Plstc, Fr/ 1058747	1
▲	5 1059005	(30000000-40000000)	Seal, Org, Fr/ 1058747, Replmt	1
▲	6 611815	(30000000-40000000)	Retainer, Plate [Pmf]	1
▲	7 1059004	(30000000-40000000)	Tool, Wndw, Plstc, Fr/ 1058747	1
▲	8 611817	(30000000-40000000)	Ferrule, Pm02/.18tube	1
▲	9 611818	(30000000-40000000)	Trigger, Handle Pmf	1
▽	10 1059130	(30000000-40000000)	Hose Assy, 10ft, F/1058747, Replmt	1
▲	11 150921	(30000000-40000000)	Fitting, Ss, Qdc, Pm02 [Ser 5]	1
▲	12 150521	(30000000-40000000)	Fitting, Brs, Str, Bm02/Pf02	1
	N/S 220040	(30000000-40000000)	Bag, Hose, Accssry, 24x36[W/Draw String] (Optional)	1

▽ ASSEMBLY

▲ INCLUDED IN ASSEMBLY

PUMP-UP CARPET SPRAYER

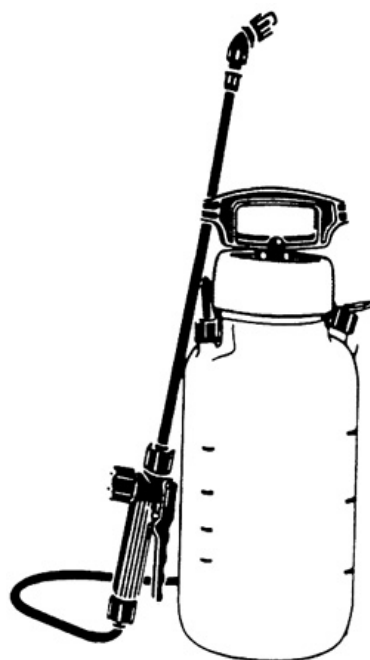

Ref.	Part No.	Serial Number	Description	Qty.
	605848	(30000000-40000000)	Sprayer 2gal Pumpup Hd	1

DOCUMENTATION GROUP

Ref.	Part No.	Serial Number	Description	Qty.
	9012806	(30000000–40000000)	Manual, Parts [Speed Ex, En]	1
	9003765	(30000000–40000000)	Manual, Oprtr [Extractor, En/Es/Fr]	1
	9004230	(30000000–40000000)	Instr, Use&Care, Wallchart [Speed Ex]	1



To view, print, order, download the latest Parts manual, other language Operator manuals, and Use and Care Guides (wall charts), visit:

www.nobles.com/manuals

