

TRIDENT COMPACT 17" 24VDC (S/N 5000001 81UP)

TRIDENT
COMPACT
HARDFLOOR SCRUBBER

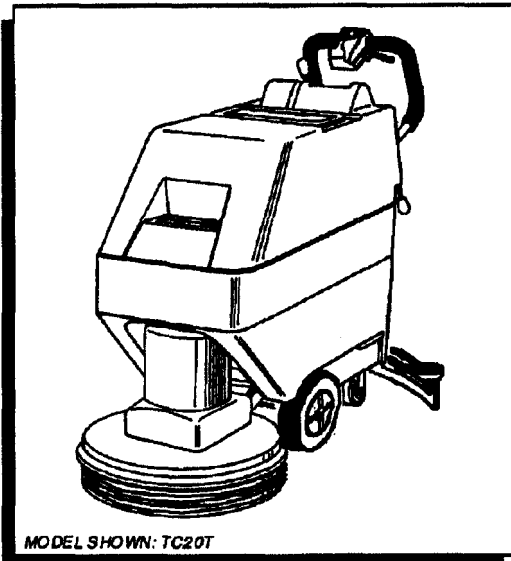

Operating Instructions (ENG)



MODELS:

TC17/20- 17"/20" Non-Traction

TC17T/20T-17"/20" Traction

TC17PK/20PK-17"/20" Pump Kit, Non-Traction

TC17BJ/20BJ-17"/20" Non-Traction (Japan)

TC17TJ/TC20TJ-17"/20" Traction (Japan)

QUEST ... for Continuous Improvement.
Windsor's Quality Management System is Certified ISO 9001.



Read these Instructions before operating the machine.

MACHINE DATALOG



MODEL ..	_____
DATE OF PURCHASE ..	_____
SERIAL NUMBER ..	_____
SALES REPRESENTATIVE ..	_____
DISTRIBUTOR NAME ..	_____
OPERATIONS GUIDE NUMBER .. 98417	
©Copyright 1996 Windsor Industries. Printed in USA	

TABLE OF CONTENTS

Cover	1	Vac Motor Assembly Parts List	17
Data Log/ Table of Contents	2	Squeegee Assembly	18
Safety Precautions	3	Squeegee Assembly Parts List	19
Operations	4	Valve Assembly	20
Operation Controls	5	Valve Assembly Parts List	21
Maintenance	6	Drive Control Assembly	22
Maintenance Cont	7	Drive Control Assembly Parts List ..	23
Maintenance Cont	8	Scrub Deck Assembly	24
Maintenance Cont	9	Scrub Deck Assembly Parts List	25
Troubleshooting	10	Electrical Controls	26
Troubleshooting Cont	11	Electrical Controls Parts List	27
Wiring Diagram (TC 17/20 Traction)	12	Mechanical Controls	28
Wiring Diagram (TC 17/20 Non-Traction)	13	Mechanical Controls Parts List	29
Tanks, and Frame	14	Drive Axle Assembly	30
Tanks and Frame Parts List	15	Drive Axle Assembly Parts List	31
Vac Motor Assembly	16	Scrub Deck Assembly (Hex Drive) ..	32
		Notes	33



SAFETY

The following symbols are used throughout this guide as indicated in their descriptions:

HAZARD INTENSITY LEVEL

There are three levels of hazard intensity identified by signal words - **WARNING**, **CAUTION** and **FOR SAFETY**. The level of hazard intensity is determined by the following definitions:



WARNING - Hazards or unsafe practices which **COULD** result in severe personal injury or death.



CAUTION - Hazards or unsafe practices which could result in minor personal injury or product or property damage.

FOR SAFETY: To identify actions which must be followed for safe operation of equipment.

For SAFETY:

DO NOT OPERATE MACHINE:

- Unless Trained and Authorized
- Unless Operation Guide Is Read and understood.
- In Flammable or Explosive areas.

WHEN USING MACHINE:

- Go slow on grades and slippery surfaces.
- Use care when backing machine.
- Do not carry riders on machine.
- Always follow basic safety and traffic rules.

BEFORE LEAVING OR SERVICING MACHINE:

- Stop on level surfaces.
- Turn off machine.

WHEN SERVICING MACHINE:

- Avoid moving parts. Do not wear loose jackets, shirts, or sleeves when working on machine.
- Block machine wheels before Jacking machine up.
- Use hoist or jack of adequate capacity to lift machine.
- Disconnect battery connection before working on machine.
- Avoid contact with battery acid.
- Use Windsor approved replacement parts.

WHEN TRANSPORTING MACHINE IN A TRAILER: ALL MACHINES

- Make sure the ramp angle is no more than 10°, and the ramp is strong enough to support the machine.
- Make sure ramp is clean and dry.
- Put ramp into position.
- Remove squeegee assembly & brushes before loading.
- Align the machine on a level surface ten (10) feet behind the ramp.

NON-TRACTION

- Push machine up ramp carefully.

TRACTION ONLY

- Turn main switch on.
- Turn the speed control knob to half speed.
- Squeeze the propel levers slowly, propelling the machine into position.
- Turn the main switch off.

ALL MACHINES

- Securely fasten the machine to the trailer.



Batteries emit hydrogen gas. Explosion or fire can result. Keep sparks and open flame away. Charge in a well ventilated area.



Flammable materials can cause an explosion or fire. Do not use flammable materials in tank(s).



Flammable materials or reactive metals can cause explosion or fire. Do not pick up.

OPERATIONS



HOW IT OPERATES

The TRIDENT COMPACT is a walk-behind scrubber. The traction machine is propelled by a DC motor. The main scrubbing components include a solution/recovery tank, single disc-type brush or pad, a rear squeegee and a vacuum motor. Detergent solution and water flow from the solution tank to the scrub brush. The rotating brush scrubs the floor. As the machine moves forward, the rear squeegee collects the dirty solution and channels it into the vacuum of the squeegee pickup hose. The pickup hose deposits the dirty solution into the recovery tank.

**PREPARING FOR OPERATION
(PERFORM DAILY MAINTENANCE AS SHOWN ON PAGE 6.)**

Fill Solution Tank

- 1.) Remove cover and fill. (see item 19, page 14)
- 2.) Use a clean bucket or hose to fill the tank with water.



Do not use water temperatures in excess of 1405 F (605 C). Water which is too hot may distort the polyethylene tanks.

3) Add a cleaning concentrate for use in automatic floor scrubbers. Closely follow the manufacturer's instructions found on container. Read ingredients listed on the container to ensure compatible chemicals are used.



Use only the suitable chemicals listed below. Using incompatible chemicals may damage the machine. Damages of this type are not covered under the WINDSOR Three Year Protection Plan. Carefully read ingredients on manufacturer's label before using any product in this machine.

SUITABLE CHEMICALS

- Alkalis
- Defoaming Agents
- Detergents
- Hydroxides

INCOMPATIBLE CHEMICALS

- Aldehydes
- Carbon Tetrachloride
- Chlorinated Hydrocarbons
- Methyls (MEK)
- Perchlorethylene (perc)
- Phenols
- Trichlorethylene
- D-Limonene



Use caution when operating the machine on a ramp or incline. (Not to exceed 2%)

**OPERATING THE MACHINE
(PERFORM DAILY MAINTENANCE AS SHOWN ON PAGE 6.)**

1. Adjust the operator control handle to a comfortable position. (see item 4, page 5)
2. Switch on main power switch. (see item 1, page 5)
3. Release solution. (Pull solution control lever rearward.) (see item 8, page 5) NOTE: The amount of solution can be regulated during operation depending on the type of floor and the traverse speed of the machine. Pulling the lever farther rearward releases more solution.
4. Switch on brush drive motor. (see item 2, page 5)
5. Switch on vacuum motor. (see item 3, page 5)
6. Lower scrub deck. Pull scrub deck lift lever rearward. (see item 10, page 5)



Do not leave brush running on floor while machine is stationary.

7. Lower squeegee. Pull squeegee lift lever back. (see item B, page 5) NOTE: Adjust squeegee as shown on page 9.
- 8a. Move machine forward by applying even pressure on the main handle.

TRACTION ONLY



for description on Traction

Move control handles slow at first until you are comfortable with operation.

TO SCRUB:
Plan your scrubbing route in advance. Try to arrange long runs with minimum stopping and starting. Do an entire floor section at a time. Pick up any debris that is oversized and remove bulky debris from aisles before scrubbing. Pick up pieces of wire, string etc., which could become entangled in the scrub brushes. Then sweep or dust mop the area prior to wing scrubber.

Adjust the machine speed, scrub deck pressure, and solution flow as required. Use minimum scrub brush pressure and solution flow required for the best possible scrubbing results.



TRIDENT COMPACT 17" 24VDC (S/N 500001 & UP)



OPERATION CONTROLS

- 2 **Main Power Switch.** Turns power to machine on/off.
- 2 **Brush Switch.** Turns brush on/off.
- 3 **Vacuum Switch.** Turns vacuum motor on/off.
- 4 **Main Handle.**
- 5 **Battery Charge Level Indicator.**
- 6 **Brush Motor Circuit Breaker.** Protects brush motor from overheating.
- 6A **Control Circuit Breaker.** Protects controls, traction motor (traction model) and pump (pump kit option).
- 7 **Vacuum Motor Circuit Breaker.** Protects vacuum motor from overheating.
- 8 **Solution Lever.** Controls the amount of solution flow to the floor.
- 9 **Squeegee Lift Lever.** Raises and lowers squeegee.
- 10 **Scrub Deck Lift Lever.** Raises and lowers scrub deck.
- 11 **Pump Motor Switch (OPTIONAL)** Turns Pump motor on/off.
- 12 **Recovery Tank Drain Hose.**
- 13 **Solution Tank Drain Hose.**
- 14 **Speed Control. (TRACTIONDRIVE ONLY)** Adjusts drive motor speed
- 15 **Squeegee Release Latch.** Releases the rear squeegee blade for adjustment or replacement.
- 16 **Battery Compartment Door Latch.** Opens back of machine for access to batteries.
- 17 **Vacuum Hose.**
- 18 **Battery Connector.**

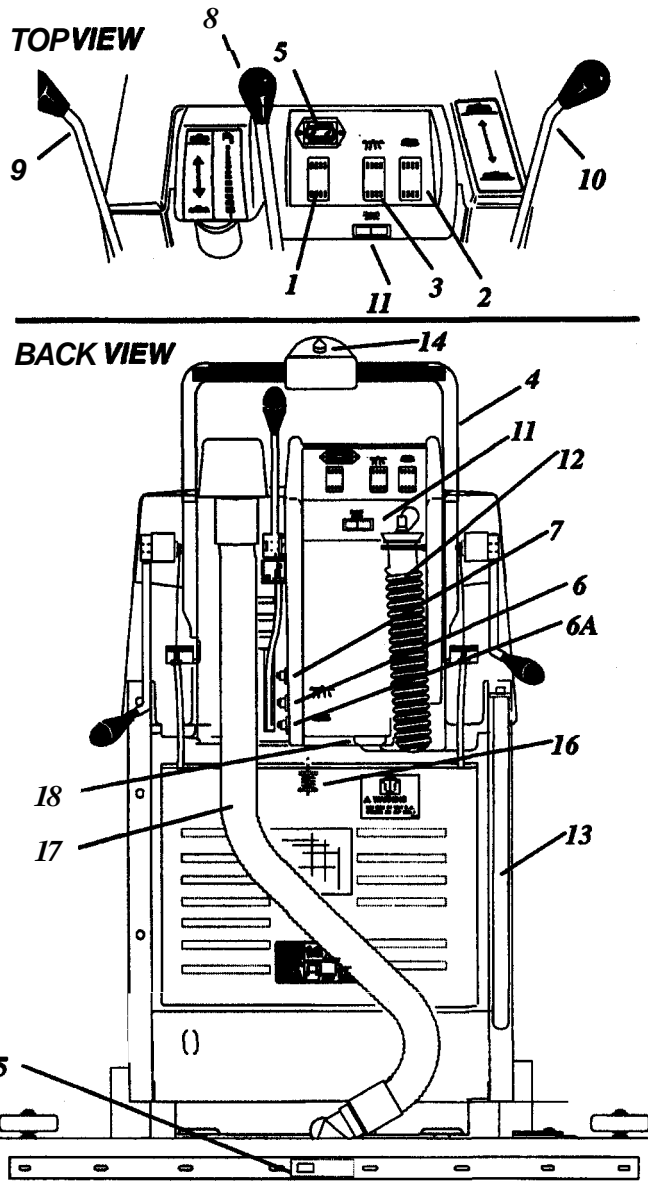

TRACTIONDRIVE CONTROLS (TRACTION DRIVE ONLY)

- A The speed the machine will travel is regulated by the knob located on the proper control found on the main handle. Turn the knob to the right to increase the travel speed of the machine.
- B Squeezing one or both of the control levers will propel the machine forward, at the selected speed.
- C Releasing both control levers will stop the machine.

TRIDENT COMPACT 17" 24VDC (S/N 500001 & UP)

1 **TENANCE**



Maintenance Item	Daily	Weekly	Monthly	Annually
Check Battery water level	1			
Check Vac Hose Connections	1			
Clean the Squeegee Blades	1			
Inspect Brush or Pad	1			
Inspect Vac Fan Foam Breaker	1			
Drain & Rinse Tanks	1			
Raise Squeegee Assembly	1			
Charge the Batteries (see page 7)	1			
Remove the Brush/Pad	1			
Check the Brush/Pad for Damage and or wear	1			
Clean Squeegee Blades & Foam Breaker	1			
Remove lint build-up from screen in the recovery tank well.	1			
Remove tank lid and allow recovery to dry between uses.	1			
Check Battery Cells w/Hydrometer		1		
Check Solution Strainer		1		
Check Casters & Wheels for proper lubrication		1		
Inspect Tanks and Hoses		1		
Check Tire Pressure. (Traction Only) Tire Pressure should be 36 PSI		1		
Clean tops of Batteries and Tray			1	
Check Battery Cable Clamps			1	
Inspect all Motors for Carbon Motor Brush wear.				1

- NOTE:**
1. Details on these maintenance items can be found on the following pages.
 2. Periodically inspect the recovery tank and decontaminate if necessary, using a Hospital Grade **Virucide** or a 1-10 bleach to water solution. Wastewater should be disposed of properly.
 3. Occasionally check in line filter screen, rinse with hot water if necessary.
 4. Frayed or cracked hoses should be replaced to avoid vacuum or solution pressure loss.

LUBRICATION:

The following symbols are found throughout the manual indicating the items requiring lubrication:



Apply Grease



Use spray Lubricant.



Thread Locker (Red or blue).



Use Anti-Seize when repairing.

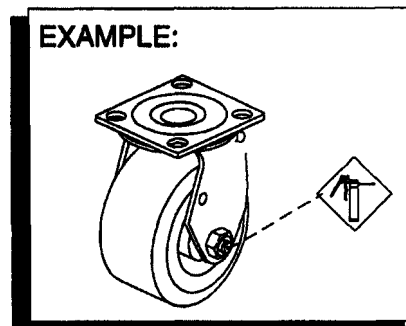

MAINTENANCE



BATTERIES

Battery Maintenance:

1. When cleaning batteries use a solution of baking soda and water. (Do not allow cleaning fluid to enter inside battery cells.)
2. Keep proper electrolyte level in battery cells.
3. Wipe down the battery tops at least once a week. If a cell should accidentally overflow, clean immediately.
4. Test battery condition with a hydrometer at least once a week.
5. Ensure that all connections are tight and that all corrosion is removed.
6. Every 4 to 6 months remove batteries from the machine and clean the battery compartment.

Battery Charging Procedure:

Check electrolyte level prior to charging to ensure plates are covered. Charge the batteries when charge level indicator flashes. The flashing indicator indicates that there is about 20% charge left in the batteries. Do not let the batteries completely drain before charging.



DO NOT SMOKE, HAVE OPEN FLAMES, OR SPARKS NEAR BATTERIES AT ANY TIME.



WEAR EYE PROTECTION AND PROTECTIVE CLOTHING WHEN WORKING WITH BATTERIES.



CHARGE BATTERIES IN A WELL VENTILATED AREA, PRIOR TO CHARGING CHECK ELECTROLYTE LEVEL IN BATTERIES TO ENSURE THE CELLS ARE COVERED, IF PLATES ARE EXPOSED, COVER WITH DISTILLED WATER.

1. Use a 24 volt, 10 amp output, D.C. charger for 105 A/H batteries. Select a charger which turns itself off when the batteries are fully charged. The charger must have a connector that matches the machine's battery connection.
2. Read the instructions and warnings provided by the battery charger manufacturer.
3. Set the charger in a well ventilated area on a level surface. Make sure cords will easily reach outlets on both machine and wall.
4. Connect charger to D.C. connector on battery pack first.

Battery Charging Procedure: (Continued)

5. Connect the A.C. power cord to properly grounded wall socket. **NEVER MAKE THE A.C. CONNECTION FIRST, HAZARDOUS SPARKS MAY RESULT.**
6. After the batteries are completely charged disconnect the charger from the A.C. wall socket.
7. Once the charger is disconnected from the A.C. wall socket it is safe to disconnect the charger from the machine.
8. When the batteries are fully charged, check the electrolyte level again by removing the caps on top of the batteries. If necessary fill the cells with distilled water as shown in the diagram to the right. Be careful not to overfill cells.

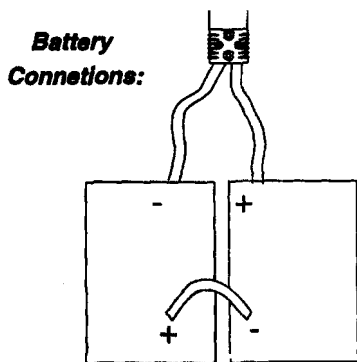
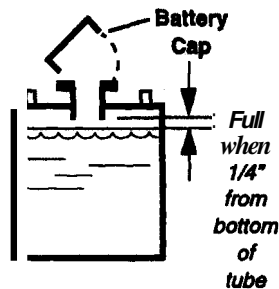

BRUSH

Brush Installation:

1. Slide brush or pad driver under drive plate.
2. Align one metal lug on the brush or pad driver with the scrub deck sight hole and a keyhole in the drive plate.
3. Raise the brush or pad driver upward and twist clockwise until locked.

Brush Removal:

1. Raise brush or pad driver off floor.
2. Reach under brush or pad driver and rotate so that the metal lug in the drive plate is visible through the scrub deck sight hole.
3. Quickly twist brush or pad driver counterclockwise to release.

MAINTENANCE



VACUUM MOTOR

7. Disconnect battery leads and remove batteries from compartment.
2. Remove (6) bolts holding vac motor/ plate assembly to recovery tank.
3. Disconnect vac motor lead from connector and lift out vac motor/ plate assembly.
4. Check motor brushes. When worn to 3/8" replace both brushes.

After the machine has been used for any wet pick-up, allow the vacuum motor to run 1-2 minutes, to help reduce moisture build-up in the vacuum motor. Drying out the vacuum motor after each use will extend the life of your vacuum motor.



Hazardous Voltage. Shock can result. Disconnect batteries before working on machine. Only qualified personnel should work inside machine.

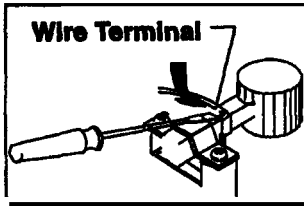

Important: When replacing carbon vac motor brushes loosen wire terminal **BEFORE!** removing screws on bracket.

Important:

Replace carbon vac motor brushes if worn down to 3/8" in length. These brushes wear quicker as the length shortens due to increased heat.

Spring inside brush housing will damage motor if brushes are allowed to completely wear away.

Note: Place stop in groove.

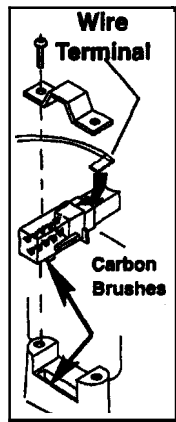

NOTE: Periodically check the length of the carbon brushes. Replace carbon brushes which are less than 3/8" long.

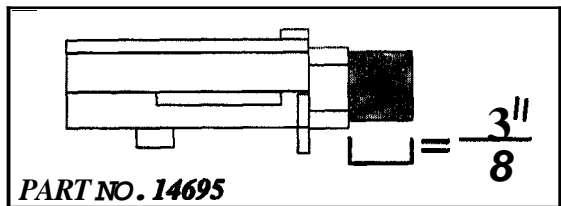

PROPEL MOTOR

The Trident Compact achieves its forward motion by a direct drive connection between the propel motor and drive differential.

Check brushes on propel motor.

If a problem arises with the propel motor please contact your WINDSOR distributor.

TIRE PRESSURE
(TRACTION MODELS ONLY)
Tire pressure should be 36 PSI.

PUMP ASSEMBLY

(On models equipped with auxiliary pump)

1. Remove batteries and squeegee assembly. Lay the machine on it's side.
2. Disconnect pump motor leads. Remove (4) nuts holding pump to chassis. Disconnect solution hoses from pump head and lift out pump. See parts list for replacement parts.



When replacing hose barb on the pump head- DO NOT OVERTIGHTEN- as this could crack intake and exhaust ports in pump head.



SQUEEGEE ASSEMBLY

Before and during use of machine, use a damp cloth to wipe the outside and inside of squeegee to remove buildup of foreign material on the squeegee blades. This prevents streaking and residue on the floor.

Squeegee wear:

After extended use, the squeegee blades will wear. To improve squeegee performance and extend wear, proceed as follows:

1. Turn off all switches and place the machine on a level surface. Raise the squeegee to the transport position.
2. Loosen knobs on the left and right hand sides of squeegee until squeegee can be removed from the squeegee bracket.
3. Loosen the fasteners on front of squeegee to replace or adjust front blade.
4. Unlatch rear squeegee latch to replace rear blade.

Adjusting Squeegee Assembly

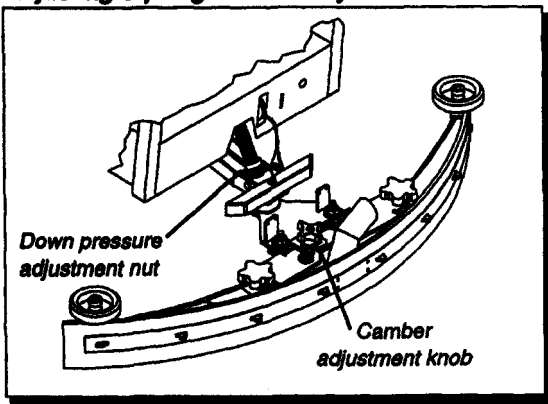

1. Lower the squeegee and move the machine forward.
2. Observe the level of the squeegee for an even curl along the length of the blade. Use camber adjustment knob to achieve even curl if required.
3. Adjust the down pressure nut located on squeegee mounting assembly. Do not apply excessive force.

SQUEEGEE DEFLECTION

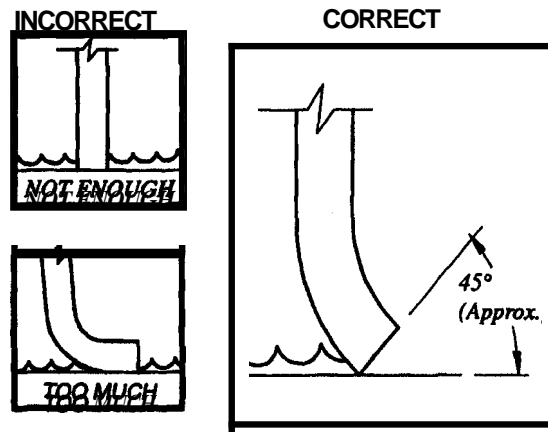

SOLUTION STRAINER

1. An inline solution strainer is located under chassis behind left wheel. Remove sediment bowl and screen periodically and rinse clean with hot water. Be careful not to misplace the gasket.

OPERATING MACHINE WITH ACCESSORY TOOLS

(PUMP OPTION ONLY)

The HFT (hard floor tool) for wet pick-up can be used on models equipped with the auxiliary pump kit option. (NOTE: Factory installed option only.)

1. Remove vac hose from squeegee and connect to accessory vac hose, using metal hose coupler.
2. Connect solution hose from accessory tool to solution outlet nipple (item 17, page 21) located at lower right hand corner of rear panel.
3. Check solution tank for cleaning solution and make sure dome is in place.
4. Switch on main power switch.
5. Switch on auxiliary pump and vacuum switches.



WARNING

Do not switch on brush motor when operating machine with accessory tools.

TROUBLE SHOOTING GUIDE



**NON-TRACTION DRIVE CONTROL SYSTEM
(REFERENCE WIRING DIAGRAM, PAGE 13)**

PROBLEM	PROBABLE CAUSE	CORRECTIVE ACTION
No Power	Battery cables corroded at battery terminals.	1. Clean battery cable clamps and battery terminals. 2. Check voltage at points A and B. Voltage should be 22/26 VDC.
	Faulty main switch.	1. Check voltage at points C & B, Voltage should be 22/26 VDC. 2. Turn main switch on and check voltage at points D & B. Voltage should be 22/26 VDC. If no voltage remove leads and check switch for continuity.
	Control Circuit Breaker tripped.	Reset control circuit breaker (3 amp or 15 amp).
Vacuum motor does not run.	Circuit Breaker tripped.	Reset vac motor circuit breaker (25 amp).
	Loose connection.	Check motor lead connections at terminals.
	Faulty Vac Switch.	Remove leads and check switch for continuity. Replace as needed.
	Faulty Vac Relay	With main switch "ON" and vac switch "ON" check voltage at points I & B and M & B. Voltage should be 22/26 VDC.
	Faulty Vac Circuit Breaker.	With main switch "ON" and vac switch " ON " check voltage at points J & B. Voltage should be 22/26 VDC.
	Motor brushes worn.	Check motor brushes. Replace when worn to 3/8". With batteries fully charged and motor secured, apply battery voltage directly to motor. The amp draw of motor should be between 18-24 amps.
Brush motor does not run.	Circuit Breaker tripped.	Reset Circuit Breaker (35 amp).
	Loose Connections.	Check motor leads at terminal block connections.
	Faulty Brush Switch.	Remove leads and check switch for continuity. Replace as needed.
	Faulty Brush Relay.	With main switch "ON" and brush switch "ON" check voltage at points K & B. Voltage should be 22/26 VDC.
	Faulty Brush Circuit Breaker.	With main switch "ON" and brush switch "ON" check voltage at points K & B and H & B. Voltage should be 22/26 VDC.
	Motor brushes worn.	Check motor brushes. Replace when worn to 3/8". With batteries full charged and motor secured, apply battery voltage directly to motor. The amp draw of motor should be between 20-25 amps (20" model) 17-20 amps (17" model).



TROUBLE SHOOTING GUIDE MAINTENANCE

**TRACTION DRIVE CONTROL SYSTEM
(REFERENCE WIRING DIAGRAM, PAGE 12)**

PROBLEM	CORRECTIVE ACTION
Loose Connections	Check all connections in propel motor circuit especially at U, Q, R & P.
Faulty micro switch	With the batteries disconnected, disconnect the wire leads to the micro switch, at V, and test for continuity. When the control levers are squeezed the micro switch is engaged. There should be a slight clicking sound when the switch is engaged. Adjust or replace as necessary.
Faulty main power switch	With the batteries disconnected, test the main power switch for continuity. Replace as necessary.
Faulty potentiometer	With the drive motor disconnected, test the output voltage at G. The output voltage should vary from 0 to 24 volts as the potentiometer U on the controls is adjusted and the control levers are squeezed. Resistance of the potentiometers can be tested at the green and black leads found at the molex connector. The resistance should vary from 0- to 2.5 ohms as the potentiometer (see item 7, page 20) on the controls is adjusted with the control levers squeezed. If these fail, the potentiometers will both need to be replaced.
Faulty control board	Test voltage at Q should be from 0 -24 VDC as speed control pot is turned. If the voltage at P is good but the voltage at Q does not vary with the speed control pot, and all the tests above have been done, replace the control board.
Faulty motor	Apply direct 24 VDC to motor at G. If it doesn't turn, replace drive assembly.

TRIDENT COMPACT 17" 24VDC (S/N 500001 & UP)

WIRING DIAGRAM (TC17/20 Traction)

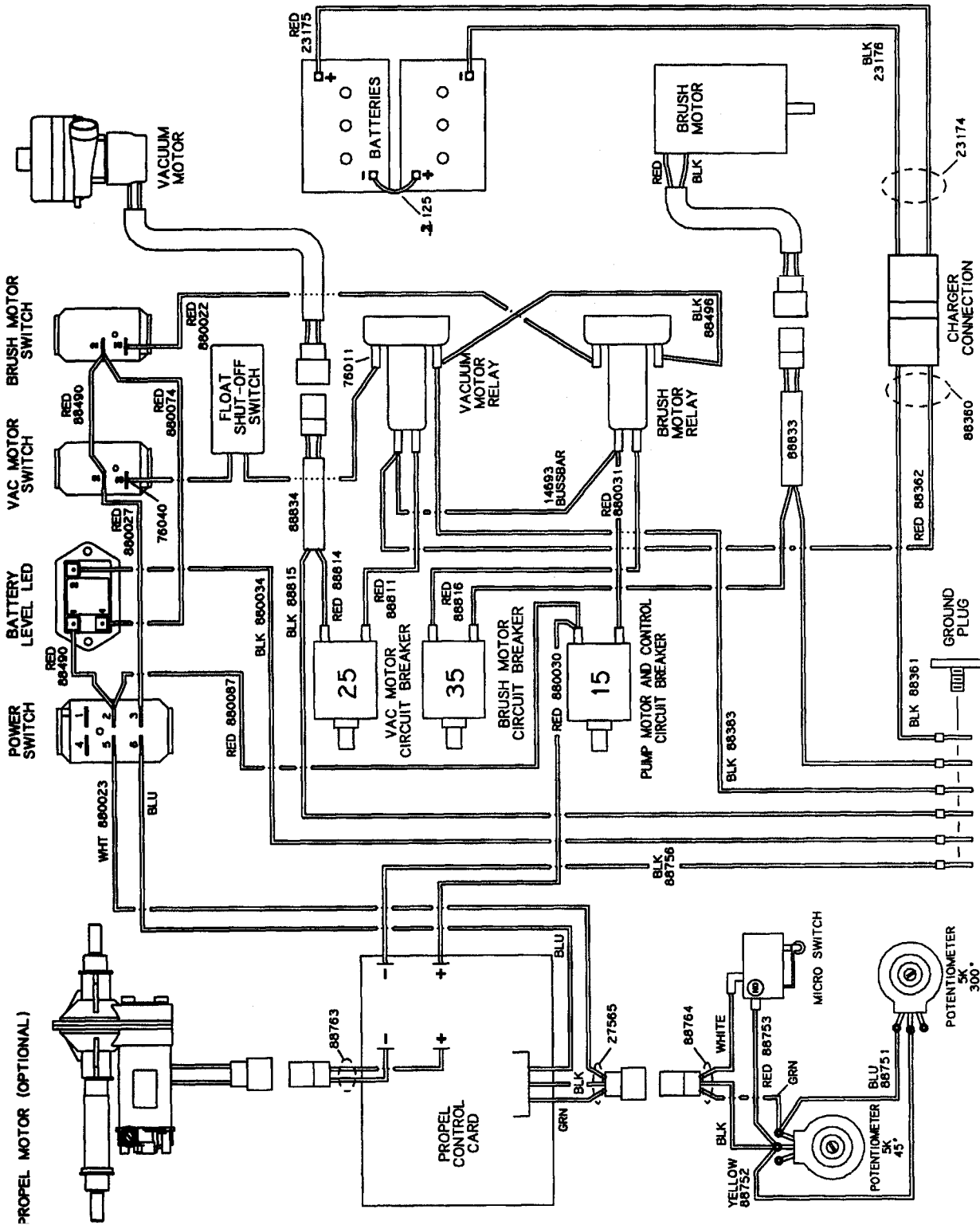

TRIDENT COMPACT 17" 24VDC (S/N 500001 & UP)



WIRING DIAGRAM (TC17/20 Non-traction)

