

*AIR MOVER*TM

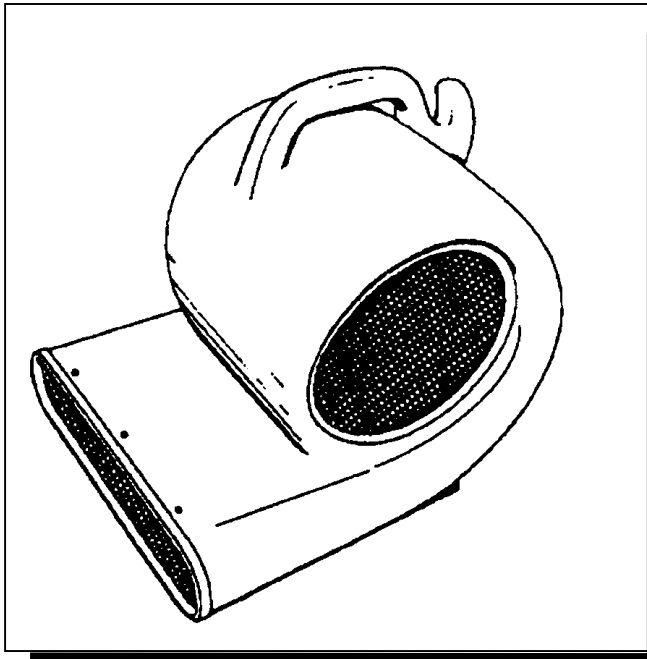

Operating Instructions (ENG)

MODEL: AM115V

QUEST ... For Continuous Improvement.
Windsor's Quality Management System is Certified ISO 9001.

Read instructions before operating the machine.

THIS PAGE LEFT BLANK INTENTIONALLY

MACHINE DATA LOG/OVERVIEW

MODEL _____

DATE OF PURCHASE _____

SERIAL NUMBER _____

SALES REPRESENTATIVE # _____

DEALER NAME _____

OPERATIONS GUIDE NUMBER _____

PUBLISHED _____

Copyright 1995 Windsor Industries, Printed in USA

YOUR DEALER

Name: _____

Address: _____

Phone Number: _____

HOW TO USE THIS MANUAL

This manual contains the following sections:

- HOW TO USE THIS MANUAL
- SAFETY
- OPERATIONS
- MAINTENANCE
- PARTS LIST

The HOW TO USE THIS MANUAL section will tell you how to find important information for ordering correct repair parts.

Parts may be ordered from authorized Windsor dealers. When placing an order for parts, the machine model and machine serial number are important. Refer to the MACHINE DATA box which is filled out during the installation of your machine. The MACHINE DATA box is located on the inside of the front cover of this manual.

MODEL _____
DATE OF PURCHASE _____
SERIAL NUMBER _____
SALES REPRESENTATIVE # _____
DEALER NAME _____
OPERATIONS GUIDE NUMBER _____
PUBLISHED _____

Copyright 1995 Windsor Industries, Printed in USA

The model and serial number of your machine is on the bottom back-end of the machine.

The SAFETY section contains important information regarding hazard or unsafe practices of the machine. Levels of hazards is identified that could result in product or personal injury, or severe injury resulting in death.

The OPERATIONS section is to familiarize the operator with the operation and function of the machine.

The MAINTENANCE section contains preventive maintenance to keep the machine and its components in good working condition. They are listed in this general order:

- Power cord
- Dust in motor windings
- Motor sleeve bearings

The PARTS LIST section contains assembled parts illustrations and corresponding parts list. The parts lists include a number of columns of information:

- **REF** – column refers to the reference number on the parts illustration.
- **PART NO.** – column lists the part number for the part.
- **QTY** – column lists the quantity of the part used in that area of the machine.
- **DESCRIPTION** – column is a brief description of the part.
- **SERIAL NO. FROM** – column indicates the first machine the part number is applicable to. When the machine design has changed, this column will indicate serial number of applicable machine. The main illustration shows the most current design of the machine. The boxed illustrations show older designs.
- **NOTES** – column for information not noted by the other columns.

NOTE: If a service or option kit is installed on your machine, be sure to keep the KIT INSTRUCTIONS which came with the kit. It contains replacement parts numbers needed for ordering future parts.

TABLE OF CONTENTS

Machine Data Log/Overview.2

HOW TO USE THIS MANUAL

How to use this Manual.3
Table of Contents.....4

SAFETY

Important Safety Instructions.....5
Hazard Intensity Level.....6
Grounding Instructions.7

MAINTENANCE

Power Cord.8
Dust in Motor Windings.8
Lubricating Motor Sleeve Bearings.....8
Wiring Diagram.....8

GROUP PARTS LIST

AM Blower Assembly.....9
AM Blower Parts List.....10
Suggested Spare Parts/Notes.....11
Warranty.12

IMPORTANT SAFETY INSTRUCTIONS

When using an electrical appliance, basic precaution must always be followed, including the following:

READ ALL INSTRUCTIONS BEFORE USING THIS MACHINE.



To reduce the risk of fire, electric shock, or injury:

Use only indoors. Do not use outdoors or expose to rain.

Use only as described in this manual. Use only manufacturer's recommended components and attachments.

If the machine is **not working properly**, has been dropped, damaged, left outdoors, or dropped into water, return it to an authorized service center.

Do not operate the machine with any openings blocked. Keep openings free of debris that may reduce airflow.

Machine can cause a fire when operating near flammable vapors or materials. Do not operate this machine near flammable fluids, dust or vapors.

This machine is suitable for commercial use, for example in hotels, schools, hospitals, factories, shops and offices for more than normal housekeeping purposes.

Maintenance and repairs **must be done** by qualified personnel.

During operation, attention shall be paid to other persons, especially children.

When leaving unattended, secure against unintentional movement.

The machine shall only be operated by instructed and authorized persons.

When leaving unattended, switch off or lock the main power switch to prevent unauthorized use.

Do not handle the plug or machine with wet hands.

Do not unplug machine by pulling on cord. To unplug, grasp the plug, not the cord.

Do not use with damaged cord or plug. Follow all instructions in this manual concerning grounding the machine.

Do not pull or carry by cord, use cord as a handle, close a door on cord, or pull cord around sharp edges or corners.

Do not pull/run machine over cord. **Keep** cord away from heated surfaces.

Connect to a **properly** grounded outlet. See Grounding Instructions.

Use only on GFCI protected receptacles.

Do not use this fan with any solid-state speed control device.

SAVE THESE INSTRUCTIONS

HAZARD INTENSITY LEVEL

The following symbols are used throughout this guide as indicated in their descriptions:

HAZARD INTENSITY LEVEL

There are three levels of hazard intensity identified by signal words -**WARNING** and **CAUTION** and **FOR SAFETY**. The level of hazard intensity is determined by the following definitions:



WARNING - Hazards or unsafe practices which COULD result in severe personal injury or death.



CAUTION - Hazards or unsafe practices which could result in minor personal injury or product or property damage.

FOR SAFETY: To identify actions which must be followed for safe operation of equipment.

Report machine damage or faulty operation immediately. Do not use the machine if it is not in proper operating condition. Following is information that signals some potentially dangerous conditions to the operator or the equipment. Read this information carefully. Know when these conditions can exist. Locate all safety devices on the machine. Please take the necessary steps to train the machine operating personnel.

FOR SAFETY:

DO NOT OPERATE MACHINE:

Unless Trained and Authorized.

Unless Operation Guide is Read and understood.

In Flammable or Explosive areas.

In areas with possible falling objects.

WHEN SERVICING MACHINE:

Avoid moving parts. Do not wear loose clothing; jackets, shirts, or sleeves when working on the machine. Use Windsor approved replacement parts.

GROUNDING INSTRUCTIONS

THIS PRODUCT IS FOR COMMERCIAL USE ONLY.

ELECTRICAL:

In the USA this machine operates on a standard 15 amp 115V, 60 hz, A.C. power circuit. The amp, hertz, and voltage are listed on the data label found on each machine. Using voltages above or below those indicated on the data label will cause serious damage to the motors.

EXTENSION CORDS:

If an extension cord is used, the wire size must be at least one size larger than the power cord on the machine, and must be limited to 50 feet (15.5m) in length.

GROUNDING INSTRUCTIONS:

This appliance must be grounded. If it should malfunction or break down, grounding provides a path of least resistance for electric current to reduce the risk of electric shock. This appliance is equipped with a cord having an equipment-grounding conductor and grounding plug. The plug must be inserted into an appropriate outlet that is properly installed and grounded in accordance with all local codes and ordinances.

This appliance is for use on a nominal 120-volt circuit, and has a grounded plug that looks like the plug in "Fig. A". A temporary adaptor that looks like the adaptor in "Fig. C" may be used to connect this plug to a 2-pole receptacle as shown in "Fig. B", if a properly grounded outlet is not available. The temporary adaptor should be used only until a properly grounded outlet (Fig. A) can be installed by a qualified electrician. The green colored rigid ear, lug, or the like extending from the adaptor must be connected to a permanent ground such as a properly grounded outlet box cover. Whenever the adaptor is used, it must be held in place by a metal screw.

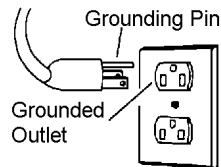

Fig. A

GROUNDING CONNECTION USING AN ADAPTOR

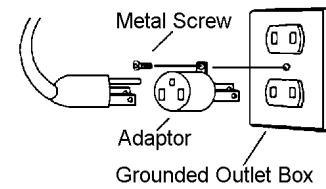

Fig. B

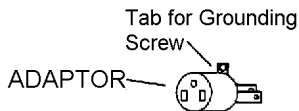

Fig. C

Note: Adaptors are not allowed in Canada.

⚠ WARNING

Improper connection of the equipment-grounding conductor can result in a risk of electric shock. Check with a qualified electrician or service person if you are in doubt as to whether the outlet is properly grounded. Do not modify the plug provided with the appliance - if it will not fit the outlet, have a proper outlet installed by a qualified electrician.

MAINTENANCE

1. Frequently inspect power cord for frayed or damaged insulation.
2. Periodically remove screen and check motor windings for dust build-up. Use a vacuum or compressed air to remove dust build-up.
3. Add a few drops of oil (SAE #20 non-detergent) to motor sleeve bearings after 3 years of normal or one year of heavy service.

WIRING DIAGRAM

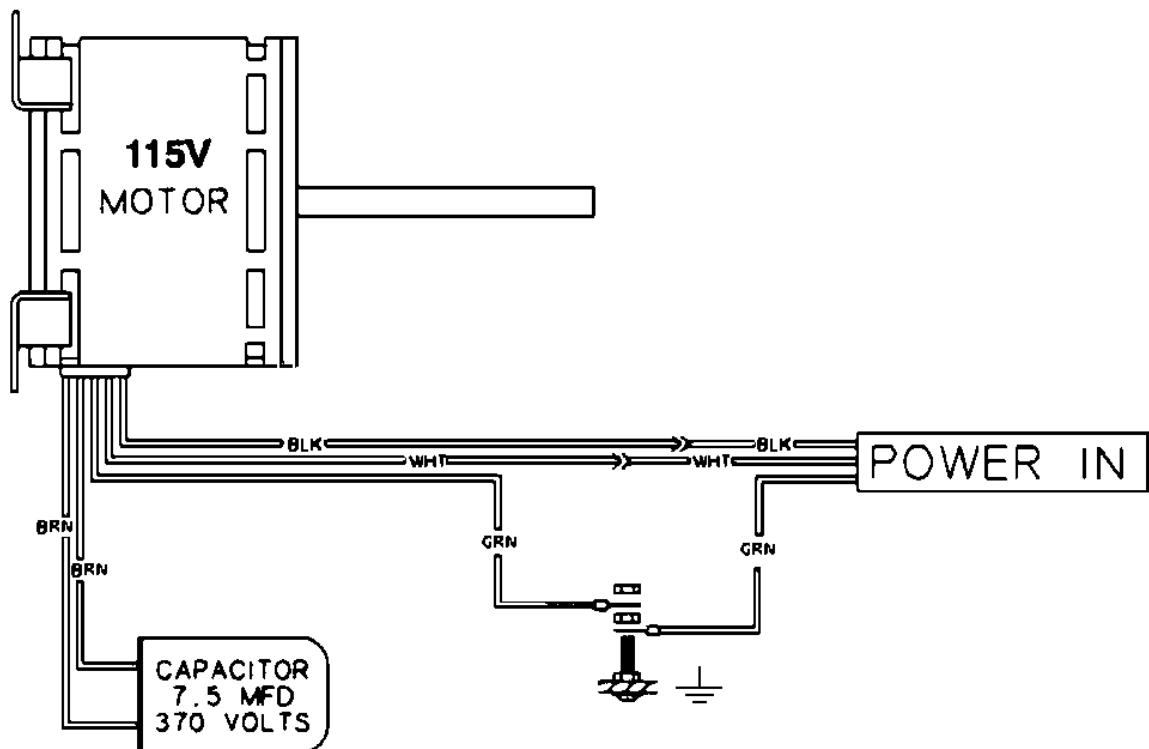

AM BLOWER ASSEMBLY

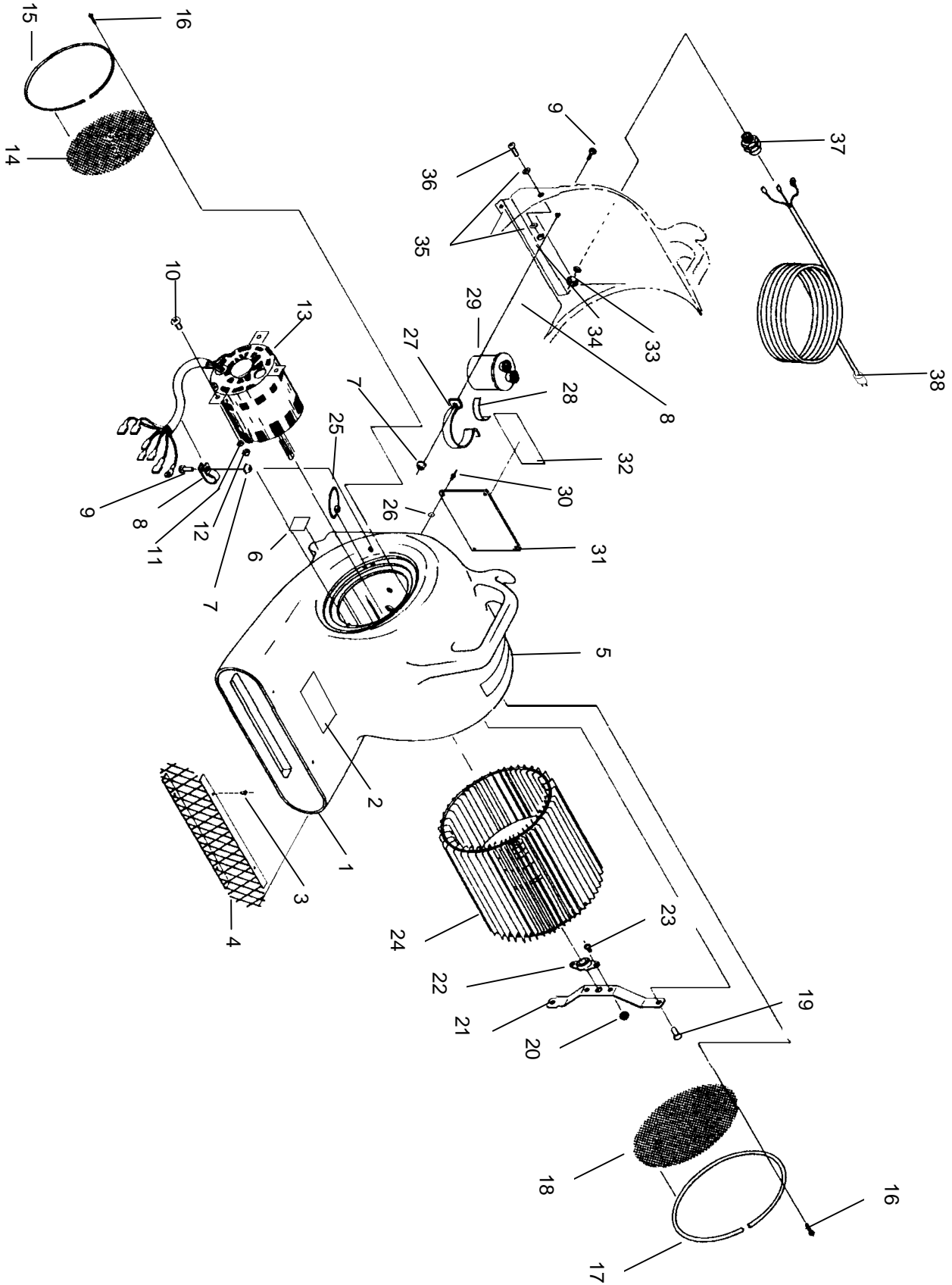

AM BLOWER PARTS LIST

REF	PART NO.	DESCRIPTION	SERIAL NO. FROM	NOTES:
1	41245	HOUSING, AIRMOVER (AM)		
2	50184	LABEL, -W- BLK/SIL		
3	67091	RIVET, 3/16 OD X 1/4 GRIP		
4	36056	GUARD, FRONT		
5	50664	LABEL, AIRMOVER MAIN		
6	50776	LABEL, FOR SAFETY		
7	57106	NUT, 8-32 W/STAR WASHER		
8	20005	CLAMP, 5/16 NYLON		
9	70374	SCR, 8-32 X 7/8 PPHMS NYL		
10	70360	SCR, 1/4-20 X .75 PPHMS PHIL		
11	87013	WASHER, 1/4 ID X 5/8 OD		
12	57047	NUT, 1/4-20 HEX NYLOCK		
13	53216	MOTOR, 115V 1SPD 1600RPM		
14	73216	SCREEN, RIGHT SIDE		
15	78134	TRIM, RIGHT SCREEN X 30.5"		
16	70219	SCR, #6 X 1/2 SHT MTL BLK		
17	78135	TRIM, LEFT SIDE X 33"		
18	73217	SCREEN, LEFT SIDE		
19	70166	SCR, 1/4-20 X 1/2 FHCS PL		
20	57030	NUT, 10-32 HEX NYLOCK		
21	14298	BRKT, MOTOR SHAFT SUPPORT		
22	09023	BEARING ASM, SHAFT SUPPORT		
23	70116	SCR, 10-32 X 5/8 FHMS		
24	34132	FAN, SQUIRREL CAGE		
25	27050	CABLE TIE, 3.5" UL/CSA		
26	87068	WASHER, 1/8 RIVET BACKUP		
27	14446	BRKT, CAPACITOR		
28	99864	TAPE, 1/32T X .75 2SA		
29	27598	CAPACITOR, 7.5MFD 370V 50/60 HZ		
30	67023	RIVET, 1/8 OD X 3/8 GRIP		
31	62214	PLATE, WARNING LABEL		
32	50344	LABEL, WARNING		
33	57176	NUT, NYLON 3/8-18 NPT CRAFTECH		
34	57104	NUT, 10-32 W/STAR WASHER		
35	87018	WASHER, #10 X 9/16 OD		
36	70386	SCR, 10-32 X 1.0 PPHMS		
37	73235	STR. RELIEF, 3/8 NPT .312 ID		
38	23620	CORD ASM, 18/3 X 15 SJTW, YL AM		

SUGGESTED SPARE PARTS LIST/NOTES

SUGGESTED SPARE PARTS LIST

PART NO.	DESCRIPTION	SERIAL NO. FROM	NOTES:
27272	CAPACITOR, 15 MFD 370V 50/60HZ		
09023	BEARING ASM, SHAFT SUPPORT		

NOTES



LIMITED WARRANTY

Windsor Industries, Inc. warrants new machines against defects in material and workmanship under normal use and service to the original purchaser. The warranty period is subject to the conditions stated below.

3 YEARS FOR PARTS AND 1 YEAR FOR SERVICE LABOR

Exceptions: Rotationally molded polyethylene tanks carry a **6 year** parts and 1 year service labor warranty. VERSAMATIC® models carry a 3 year warranty on brush motors, vacuum motors, and belts, and a 1 year service labor warranty. SENSOR® models carry a 2 year warranty on vacuum motors and belts, and a 1 year service labor warranty. Extractor brush motors, pump motors, pc boards and electronics, vac motors (other than VERSAMATIC® and SENSOR®), pumps, and FLEXSOL™ diaphragms, all RADIUS™, all ACCESS™ and TITAN™1 carry a 1 year parts and service labor warranty. Propane equipment has a 1 year parts and service warranty. The Onan® engines have a 3 year manufacturers' warranty. The Honda® engines have a 2 year manufacturers' warranty. The engine warranty is administered through the engine manufacturer and must be repaired at an authorized service center.

Normal wear items including, but not limited to, belts, brushes, capacitors, carbon brushes, casters, clutches, cords, filters, finishes, gaskets, hoses, light bulbs, rectifiers, switches, squeegees, bearings, pulleys, relays, actuating cables, tires and wheels will be warranted for manufacturing defects for 90 days from the purchase date.

The warranty commences on the purchase date by the original end user from an authorized Windsor Agent, subject to proof of purchase. The Machine Registration Card must be completed and returned immediately at the time of purchase. If proof of purchase cannot be identified, the warranty start date is 90 days after date of sale to an authorized Windsor distributor. Parts replaced or repaired under warranty are guaranteed for the remainder of the original warranty period.

90 DAY WARRANTY EXTENSION AVAILABLE

Upon receipt of the Machine Registration Card, Windsor will extend the warranty period an additional 90 days from the purchase date. Does not include items warranted 90 days for manufacturing defects.

STATED WARRANTIES ARE IN LIEU OF ALL OTHER WARRANTIES, EXPRESSED OR IMPLIED.

Any statutory implied warranties, including any warranty of merchantability or fitness for a particular purpose, are expressly limited to the duration of this written warranty. Windsor will not be liable for any other damages, including but not limited to indirect or special consequential damages arising out of or in connection with the furnishing; performance, use or inability to use the machine. This remedy shall be the exclusive remedy of the buyer.

This warranty shall not apply to: 1.damage in transit; 2.misuse or abuse(including the use of incompatible or corrosive chemicals or overloading of capacity); 3. failure due to lack of proper maintenance and care (including cleaning); 4.any design alterations performed by an organization not authorized or specified by Windsor; 5.batteries and chargers. 6. high pressure washing. 7.electrical components exposed to moisture.

If difficulty develops during the warranty period, contact the authorized Windsor Agent from whom the product was purchased. Windsor, Inc. may elect to require the return of components to validate a claim. Any defective part to be returned must be shipped freight pre-paid to an authorized Windsor Distributor/Service Center or to the Windsor factory.

USE OF PARTS NOT APPROVED BY WINDSOR, INC. WILL VOID ALL WARRANTIES.

This warranty is valid only for all products sold after July 1, 1995. A product sold before that date shall be covered by the limited Warranty in effect at the date of sale to the original purchaser.



WINDSOR INDUSTRIES, INC., 1351 W. Stanford Ave., Englewood, CO 80110 USA
Phone: 303-762-1800 Fax: 303-762-0817 Internet: www.windsorind.com