



E83018-00



CREWMAN™ DC2000

20" Dust Control
Electric Burnisher



Operator's Manual
Parts Schematic

General Instructions for the CREWMAN™ DC2000

Operating Instructions

Check machine for damage to cord or plug.

Use only Hi Speed Burnishing pads 20" or 19" diameter.

To install or change the pad:

1. Unplug the machine.
2. Tip the machine back on the wheels.
3. Remove the center-lock.
4. Center the pad on the pad driver.
5. Replace the center-lock and tighten securely.

To operate the machine:

1. Plug into a grounded outlet.
2. Release the handle and lower it.
3. The handle can be locked into a comfortable position for the operator or used free floating.
4. Press the safety lever and squeeze the trigger to start the machine.
5. Do not operate in one place as damage to the floor or finish could result.
6. The machine should be operated in the green area of the meter on the handle. Turn the knob on the back to increase or decrease the pad pressure.
7. Do not operate the machine with the handle in the upright position.
8. Remove the pad after every use.
9. Use only new or clean pads and reverse them as needed.

Specifications:

Length - 30 in.

Width - 22 in.

Height - 50 in.

Weight - 69 Lbs.

Pad Speed - 2000 RPM

Pad Diameter - 20 in.

Drive motor - 1.5 HP, 120v, 15 A, 50/60 HZ

Cord - 14-3 ST, 75 ft.

Safety

Read and understand the manual before operating this machine.

- Do not operate in explosive areas or use near flammable liquids or gases.
- Attach only to properly grounded outlet.
- Do not expose to rain, store indoors.
- Do not operate the machine with a damaged cord or plug.
- Do not block or disconnect the safety lever. •

Do not leave the machine plugged in while unattended.

- Unplug the machine before servicing.
- Do not put fingers under the pad or pad holder. •

Unplug the machine before installing or removing the pad.

- 2 • Use only with Hi Speed Burnishing pads.

Maintenance

To maintain appearance - wipe the machine with a damp cloth after use.

Warning - Unplug the machine before servicing

The operator should check the following at 250 hour intervals:

1. Check the motor brushes for wear or excessive arcing.
2. Check the cord and electrical system.
3. Check the safety lockout on the trigger.
4. Check wheels and bearings.
5. Check the Dust shroud and brush seal.
6. Check the Dust bag before each use.

BETCO US WARRANTY POLICY

10 Year Coverage

Subject to the conditions stated below, Betco warrants parts and labor on rotationally molded polyethylene tanks/housings and injection molded vacuum head assemblies to be free from defects in materials and workmanship for a period of ten years to the original purchaser.

3 Year Coverage

Subject to the conditions stated below, Betco warrants parts and labor on all other Betco components to be free from defects in materials and workmanship for a period of three years to the original purchaser.

1 Year Coverage

Subject to the conditions stated below, Betco offers a limited warranty on parts and labor on the following equipment, parts and accessories to be free from defects in material and workmanship for a period of one year to the original purchaser. DM Series Vacuums: #85506-00, #85507-00 Bac Pac Lite Vacuum: #85903-00 FiberPRO® Floor Dryer: #85507-00 WORKMAN™ Series Vacuums: #85024-00, #85025-00, #85026-00, #85027-00 CV100T Vacuum: #85023-00. All Tools and Accessories/All Battery Chargers/All Batteries are pro-rated for 1 year.

Allowable Travel Time Warranty Reimbursement

Eligible equipment: All battery and propane powered equipment products. Warranty period: 90 days from date of sale to the original purchaser. A maximum 60 mile round trip at 44 cents per mile will be allowed for warranty consideration.

Propane Machine Warranty:

Honda engines are warranted by Honda for a period of 2 years against manufacturer defect. Kawasaki engines are warranted by Kawasaki for a period of 2 years against manufacturer defect. All other components (except wear items)* are warranted by Betco for a period of 3 years.

***Wear items exempt from warranty consideration include but may not be limited to: power cords, transport wheels, vacuum bags, belts, squeegee blades, pad drivers, clutch plates, handle grips, filters, screens, throttle cables, brushes and carbon brushes.** Subject to the conditions and exceptions stated in this warranty, Betco warrants the Betco products to be free from defects in material and workmanship, under normal use and service, for the periods listed under the warranty policy to the original purchaser. At any time during the warranty period, Betco will furnish replacement parts for the Betco products to the original purchaser. Such parts will be furnished and charged including transportation costs, to the original owner through any Betco authorized Service Distributor. If the original part is returned within the warranty policy period from date of delivery for inspection by Betco and is found to be defective, the owner will be credited for the cost of replacement parts plus shipping and handling. Replacement parts that have become defective through wear or abuse are not included in this warranty. This warranty does not apply to damage or defect caused by accident, misuse, negligence, fire or to any Betco product which has been serviced or repaired by other than an authorized Betco Service Distributor or Betco factory personnel. This warranty is void if products are used for any purpose other than that which was intended. There are no other warranties expressed or implied. In no event shall Betco be liable for incidental or consequential damages or any damage to person or property. (Please note some states do not allow the exclusion or limitations for incidental and consequential damages.)

BURNISHER MODEL CREWMAN™ DC2000

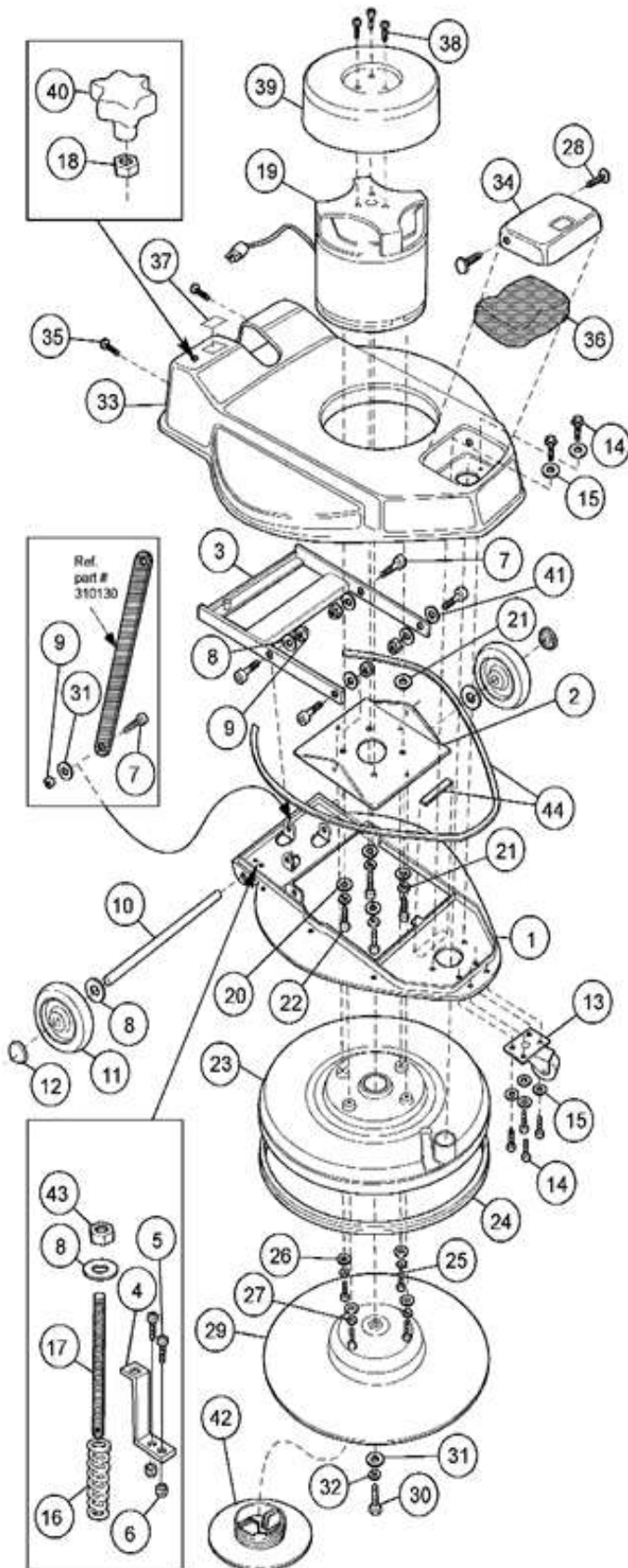

ref#	part#	NU#	description
1	E81117	310190	Base, Steel
2	E81174	310191	Plate, Motor Mount
3	E81173	310192	Bracket, Dust Control Burnisher
4	E81172	310193	Bracket, Spring Adjustment
5	E81089	110122	Bolt, 5/16 - 18 X 3/4"
6	E81063	110148	Nut, 5/16" Nylok
7	E81085	110275	Bolt, Shoulder 1/2 x 3/8
8	E83145	110103	Washer, 1/2" Nylon
9	E81076	110276	Nut, 3/8 Nylok Thin
10	E83651	310116	Axle, 1/2 x 17.25"
11	E81124	310114F	Wheel, 5"
12	E83143	110144	Cap, Axle 1/2"
13	E81126	310199	Wheel, Caster 2.5"
14	E81082	110274	Bolt, 1/4 - 20 X 3/8 with patch
15	E81713	110142	Washer, Flat 1/4"
16	E81132	110273	Spring, 4"
17	E81393	110278	Rod, Threaded, spring adjustment 5"
18	E81079	110293	Nut, 1/2"-13 Jam
19	E281109	210146	Motor, 1.5 HP 115v 2000 RPM
			Not Shown, Carbon Brush, Motor E85053, Rectifier E85042
20	E81062	110119	Washer, Flat 5/16" USS
21	E81066	110124	Washer, Lock 3/8" Split
22	E81080	110125	Bolt 3/8 - 16 x 3/4" Gr 5
23	E81144	310195	Shroud, Dust
24	E83657	310202	Brush, Extrusion, Skirt DC Burnisher
25	E83425	110150	Screw, 1/4 - 20 X 1" Ph Tr Hd
26	E81173	110142	Washer, Flat 1/4"
27	E81078	110143	Washer, Lock 1/4" Split
28	E81071	110205	Plug, Plastic ratchet 5/16"
29	E81149	310200	Pad Driver, DC Burnisher
30	E81072	110152	Bolt, 5/16 X 1"
31	E81062	110119	Washer, Flat USS 5/16"
32	E81067	110120	Washer, Lock 5/16" Split
33	E81142	310196	Cover, DC Burnisher
34	E81143	310203	Cover, Dust Bag DC Burnisher
35	E81074	110290	Screw, 10-24 X 1/2 Truss Head Zn
36	E83788	310204	Bag, Dust, Cloth
37	E83720	110291	Decal, Brush Pressure DC Burnisher
38	E81523	110227	Screw, 8-32 x 3/8 Ph Tr Hd
39	E81141	310152	Cover, Motor
40	E81229	110279	Knob, black, DC Burnisher
41	E83269	110168	Washer, Spring 1/2 in.
42	E81150	310108	Pad Holder, for replacement only
43	E81088	110277	Nut, 1/2 x 13 thin nylock
44	E81604	110338	Gaskets, 3/4 x 1/4 x 4" & 54"

BURNISHER MODEL CREWMAN™ DC2000 PARTS

Cam Lock Assembly not shown EP50064

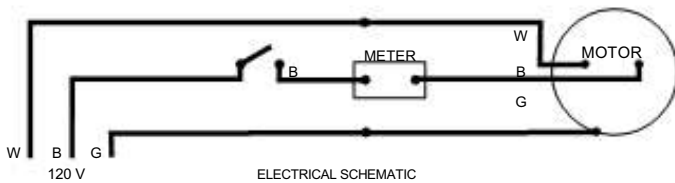
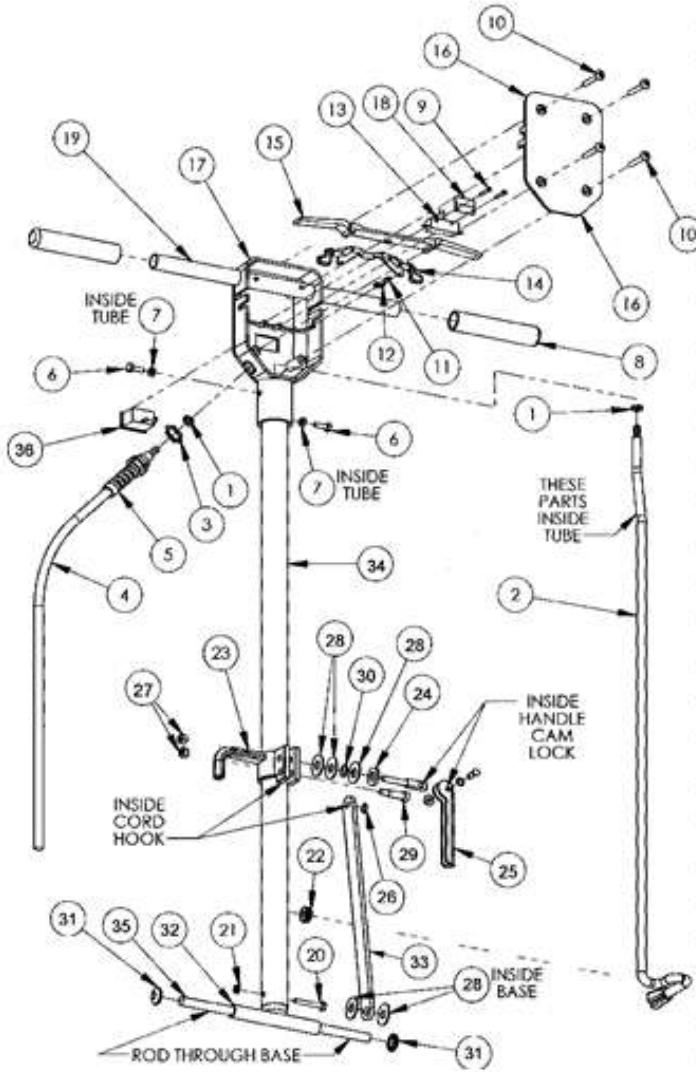

ref#	part#	NU#	description
1	E83523	110146	Nylon Cable Tie
2	E83132	210105	Cord, Handle, 14-3
3	E83789	110299	Nut, Electrical Conduit, 1/2"
4	E83790	210121	Cord, 50 Feet, 14-3ST
5	E83496	210104	Strain Relief for Replacement
6	E81064	110178	Bolt, Hex. 1/4-20 x 3/4
7	E83520	110115	Nut, Nylock, 1/4-20
8	E83127	310118	Grip
9	E83651	110116	Screw, Phillips, No. 6x1
10	E83426	110140	Screw, Phillips, 1/4-20 x 1.75"
11	E83130	110149	Spring
12	E83270	110163	Clip, Spring
13	E85032	210102A	Switch
14	E83129	310119	Safety Lock
15	E82752	310120	Trigger, Switch
16	E83325	310121	Cover, Switch Box
17	E82750	310122B	Switch Box, Handle, Dual Speed
18	E81105	310153	Plate, Switch
19	E83451	310124	Handle Tube, 7/8 x 16
20	E81065	110318	Bolt, Hex. 1/4-20 x 1.75" Grade 5
21	E81070	110319	Nut, Nylock, 1/4-20
22	E83519	210106	Grommet, .375" ID
23	E83137	310128	Cord Hook
24	E83135	110112	Oval Washer
25	E83133	310189	Handle, Cam Lock Assembly
26	E81379	110169	Washer, Spring, 3/8
27	E81063	110148	Nut, Nylock, 5/16-18
28	E83145	110103	Washer, Nylon
29	E81077	110154	Bolt, Shoulder, 3/8 x 1
30	E83269	110168	Washer, Spring, 1/2
31	E83143	110144	Caps, Axle, 0.5
32	E82717	310126A	Handle attachment, Welded
33	E83136	310130	Bracket, Flat Handle
34	E83711	310127A	Handle Tube
35	E81394	110287	Axle, 1/2 x 6.625"
36	E81216	210153	Meter, 15 Amp.



1001 Brown Avenue • Toledo, Ohio 43607-0127