

FLOOR BURNISHER

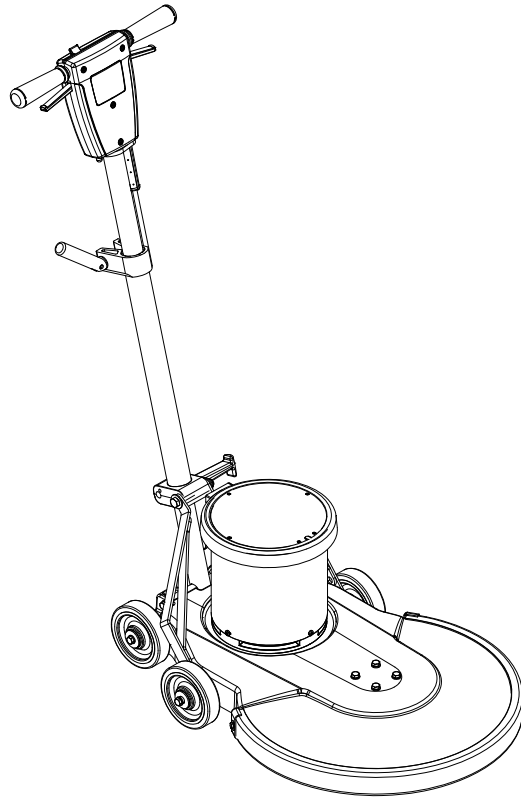

MODELS:

U1500
10090570

LB1500
10090160

SPT1500
10090360

LB1500IE
10090180

LB1500IA
10090170



Operating Instructions (ENG)



MACHINE DATA LOG

Model: _____

Date of Purchase: _____

Serial Number: _____

Sales Representative: _____

Address: _____

Phone Number: _____

NOTES:

TABLE OF CONTENTS

<i>Machine Data Log/Overview</i>	1
<i>Table of Contents</i>	3

HOW TO USE THIS MANUAL

<i>How to use this Manual</i>	1-1
-------------------------------------	-----

SAFETY

<i>Important Safety Instructions</i>	2-1
<i>Hazard Intensity Level</i>	2-2
<i>Grounding Instructions-120V</i>	2-3
<i>Grounding Instructions-230V</i>	2-4
<i>Safety Label Location</i>	2-5

OPERATION

<i>Technical Specifications</i>	3-1
<i>Handle Installation</i>	3-2
<i>Operation</i>	3-4
<i>Pad Driver Installation</i>	3-4

MAINTENANCE

<i>Machine Troubleshooting</i>	4-1
<i>Service Schedule</i>	4-2

GROUP PARTS LIST

<i>Deck</i>	5-1
<i>Drive/Pad Lock</i>	5-3
<i>Electrical</i>	5-5
<i>Handle</i>	5-7
<i>Motor</i>	5-9
<i>Wiring-120V</i>	5-11
<i>Wiring-230V</i>	5-12
<i>Suggested Spare parts</i>	5-13

HOW TO USE THIS MANUAL

This manual contains the following sections:

- HOW TO USE THIS MANUAL
- SAFETY
- OPERATIONS
- MAINTENANCE
- PARTS LIST

The HOW TO USE THIS MANUAL section will tell you how to find important information for ordering correct repair parts.

Parts may be ordered from authorized dealers. When placing an order for parts, the machine model and machine serial number are important. Refer to the MACHINE DATA box which is filled out during the installation of your machine. The MACHINE DATA box is located on the inside of the front cover of this manual.

Model:	_____
Date of Purchase:	_____
Serial Number:	_____
Sales Representative:	_____
Address:	_____
Phone Number:	_____

The SAFETY section contains important information regarding hazard or unsafe practices of the machine. Levels of hazards are identified that could result in product or personal injury, or severe injury resulting in death.

The OPERATIONS section is to familiarize the operator with the operation and function of the machine.

The MAINTENANCE section contains preventive maintenance to keep the machine and its components in good working condition. They are listed in this general order:

The PARTS LIST section contains assembled parts illustrations and corresponding parts list. The parts lists include a number of columns of information:

- **REF** – column refers to the reference number on the parts illustration.
- **PART NO.** – column lists the part number for the part.
- **PRV NO.** - Reference No.
- **QTY** – column lists the quantity of the part used in that area of the machine.
- **DESCRIPTION** – column is a brief description of the part.
- **SERIAL NO. FROM** – If this column has an (*) and a Reference number, see the SERIAL NUMBERS page in the back of your manual. If column has two asterisk (**), call manufacturer for serial number. The serial number indicates the first machine the part number is applicable to. The main illustration shows the most current design of the machine. When a boxed illustration is shown, it displays the older design.
- **NOTES** – column for information not noted by the other columns.

NOTE: If a service or option kit is installed on your machine, be sure to keep the **KIT INSTRUCTIONS** which came with the kit. It contains replacement parts numbers needed for ordering future parts.

NOTE: The number on the lower left corner of the front cover is the part number for this manual.

SAFETY

IMPORTANT SAFETY INSTRUCTIONS

When using an electrical appliance, basic precaution must always be followed, including the following:

READ ALL INSTRUCTIONS BEFORE USING THIS MACHINE.

⚠ WARNING: To reduce the risk of fire, electric shock, or injury:

Use only indoors. Do not use outdoors or expose to rain.

Use only as described in this manual. Use only manufacturer's recommended components and attachments.

If the machine is **not working properly**, has been dropped, damaged, left outdoors, or dropped into water, return it to an authorized service center.

Do not operate the machine with any openings blocked. Keep openings free of debris that may reduce airflow.

Machine can cause a fire when operating near flammable vapors or materials. Do not operate this machine near flammable fluids, dust or vapors.

This machine is suitable for commercial use, for example in hotels, schools, hospitals, factories, shops and offices for more than normal housekeeping purposes.

Maintenance and repairs **must be done** by qualified personnel.

During operation, attention shall be paid to other persons, especially children.

The machine shall only be operated by instructed and authorized persons.

When leaving unattended, unplug the machine.

Do not handle the plug or machine with wet hands.

Do not unplug machine by pulling on cord. To unplug, grasp the plug, not the cord.

Do not use with damaged cord or plug. Follow all instructions in this manual concerning grounding the machine.

Do not pull or carry by cord, use cord as a handle, close a door on cord, or pull cord around sharp edges or corners.

Do not pull/run machine over cord. **Keep** cord away from heated surfaces.

Connect to a **properly** grounded outlet. See Grounding Instructions.

If the supply cord is damaged it must be replaced by a special cord from an authorized service agent.

Unplug machine before cleaning or servicing.

Operational hazard may occur when running the machine over the supply cord.

This appliance has been designed for use with pads specified by the manufacturer. The fitting of other pads may affect its safety.

This machine is for dry use only and shall not be used or stored outdoors in wet conditions.

SAVE THESE INSTRUCTIONS

The following symbols are used throughout this guide as indicated in their descriptions:

HAZARD INTENSITY LEVEL

There are three levels of hazard intensity identified by signal words – **WARNING** and **CAUTION** and **FOR SAFETY**. The level of hazard intensity is determined by the following definitions:

WARNING:

WARNING – Hazards or unsafe practices which **COULD** result in severe personal injury or death.

CAUTION:

CAUTION – Hazards or unsafe practices which could result in minor personal injury or product or property damage.

FOR SAFETY: To identify actions which must be followed for safe operation of equipment.

Report machine damage or faulty operation immediately. Do not use the machine if it is not in proper operating condition. Following is information that signals some potentially dangerous conditions to the operator or equipment. Read this information carefully. Know when these conditions can exist. Locate all safety devices on the devices on the machine. Please take the necessary steps to train the machine operating personnel.

FOR SAFETY:

DO NOT OPERATE MACHINE:

Unless Trained and Authorized.

Unless Operation Guide is Read and Understood.

In Flammable or Explosive areas.

In areas with possible falling objects.

WHEN SERVICING MACHINE:

Avoid moving parts. Do not wear loose fitting clothing, jackets, shirts, or sleeves when working on the machine. Use approved replacement parts.

SAFETY

GROUNDING INSTRUCTIONS 120V

THIS PRODUCT IS FOR COMMERCIAL USE ONLY.

ELECTRICAL:

In the USA this machine operates on a 15 amp nominal 120V, 60 hz, A.C. power circuit. The amp, hertz, and voltage are listed on the data label found on each machine. Using voltages above or below those indicated on the data label will cause serious damage to the motors.

GROUNDING INSTRUCTIONS:

This appliance must be grounded. If it should malfunction or break down, grounding provides a path of least resistance for electric current to reduce the risk of electric shock. This appliance is equipped with a cord having an equipment-grounding conductor and grounding plug. The plug must be inserted into an appropriate outlet that is properly installed and grounded in accordance with all local codes and ordinances.

This appliance is for use on a nominal 120-volt circuit, and has a grounded plug that looks like the plug in "Fig. A". A temporary adaptor that looks like the adaptor in "Fig. C" may be used to connect this plug to a 2-pole receptacle as shown in "Fig. B", if a properly grounded outlet is not available. The temporary adaptor should be used only until a properly grounded outlet (Fig. A) can be installed by a qualified electrician. The green colored rigid ear, lug, or the like extending from the adaptor must be connected to a permanent ground such as a properly grounded outlet box cover. Whenever the adaptor is used, it must be held in place by a metal screw.

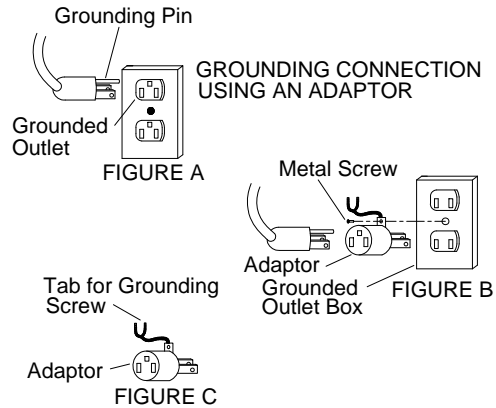

Note: Adaptors are not allowed in Canada.

! WARNING:

Improper connection of the equipment-grounding conductor can result in a risk of electric shock. Check with a qualified electrician or service person if you are in doubt as to whether the outlet is properly grounded. Do not modify the plug provided with the appliance - if it will not fit the outlet, have a proper outlet installed by a qualified electrician.

GROUNDING INSTRUCTIONS-230V

THIS PRODUCT IS FOR COMMERCIAL USE ONLY.

ELECTRICAL:

The amp, hertz, and voltage are listed on the data label found on each machine. Using voltages above or below those indicated on the data label will cause serious damage to the motors.

EXTENSION CORDS:

If an extension cord is used, the wire size must be at least one size larger than the power cord on the machine, and must be limited to 50 feet (15.5m) in length.

GROUNDING INSTRUCTIONS:

This appliance must be grounded. If it should malfunction or break down, grounding provides a path of least resistance for electric current to reduce the risk of electric shock. This appliance is equipped with a cord having an equipment-grounding conductor and grounding plug. The plug must be inserted into an appropriate outlet that is properly installed and grounded in accordance with all local codes and ordinances.

WARNING:

Improper connection of the equipment-grounding conductor can result in a risk of electric shock. Check with a qualified electrician or service person if you are in doubt as to whether the outlet is properly grounded. Do not modify the plug provided with the appliance - if it will not fit the outlet, have a proper outlet installed by a qualified electrician.

SAFETY

SAFETY LABEL LOCATION

NOTE: These drawings indicate the location of safety labels on the Machine. If, at any time, the labels become illegible contact your authorized representative for prompt replacement.

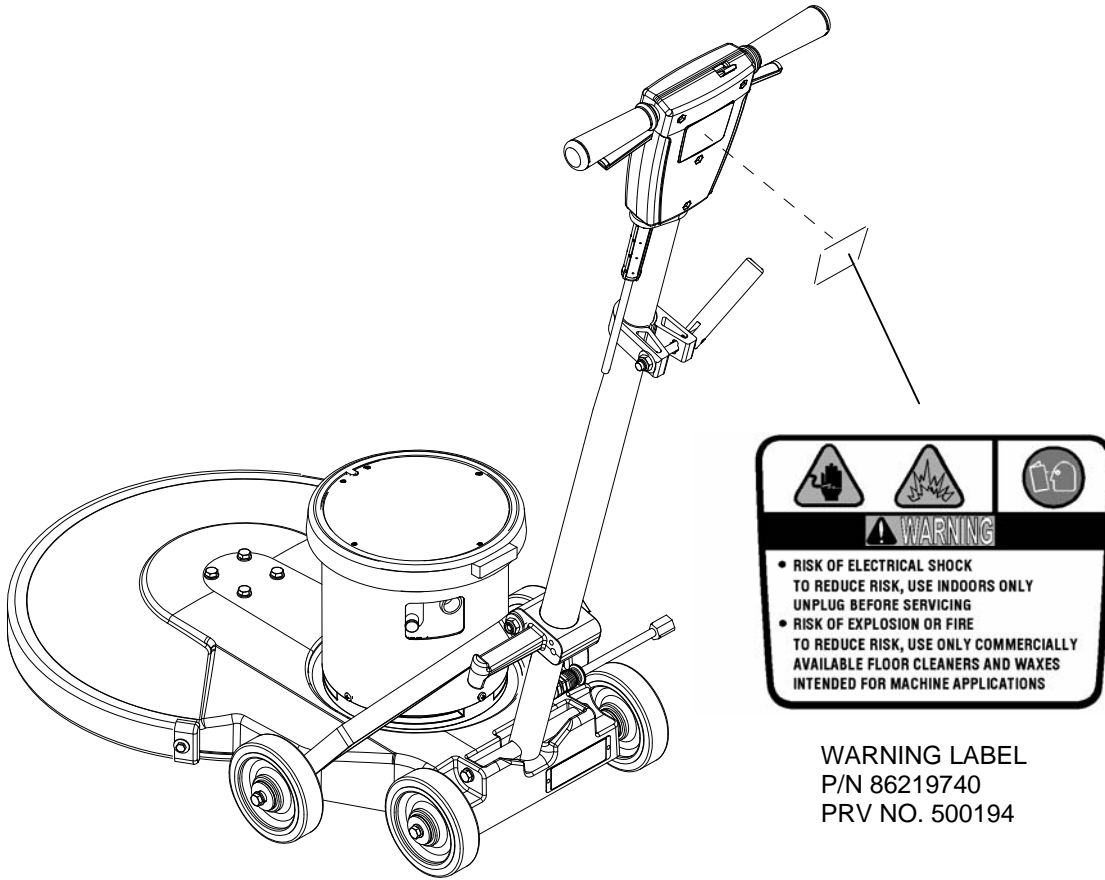

WARNING LABEL
P/N 86219740
PRV NO. 500194

TECHNICAL SPECIFICATIONS

ITEM	DIMENSION/CAPACITY/MODEL
CONSTRUCTION	Heavy-duty die cast aluminum deck with heavy-duty rubber bumper, tubular steel adjustable handle with die cast aluminum handle housing and belt driven pad.
MOTOR	1.5 hp
PAD SPEED	1500 rpm
ELECTRICAL SYSTEM	
115 volts, 60 Hz	LB1500, U1500, SPT1500
230 volts, 50 Hz	LB1500IE, LB1500IA
CABLE	75' [22.9 m]
SWITCHES	Dual levers with safety lock
WHEELS	Four 5" (12.7 cm) dia., 1.25" (3 cm) wide, non-marking tread
HANDLE	1.5" (4 cm) tubular steel, adjustable, easy to use thumb activated safety lock
DIMENSIONS (L X W X H)	31.5" (80 cm) X 21.5" (54 cm) X 43.5" (111 cm)

NOTE: Always use a pad, which has been designed for electric ultra high speed burnishing of at least 2000 rpm.

The sound pressure level at the operator's ear was measured to be 62 dBA. This was a nearfield, broad-band measurement taken in a typical industrial environment on a tile floor. This appliance contains no possible source of impact noise. The instantaneous sound pressure level is below 63 Pa.

OPERATION

HANDLE INSTALLATION

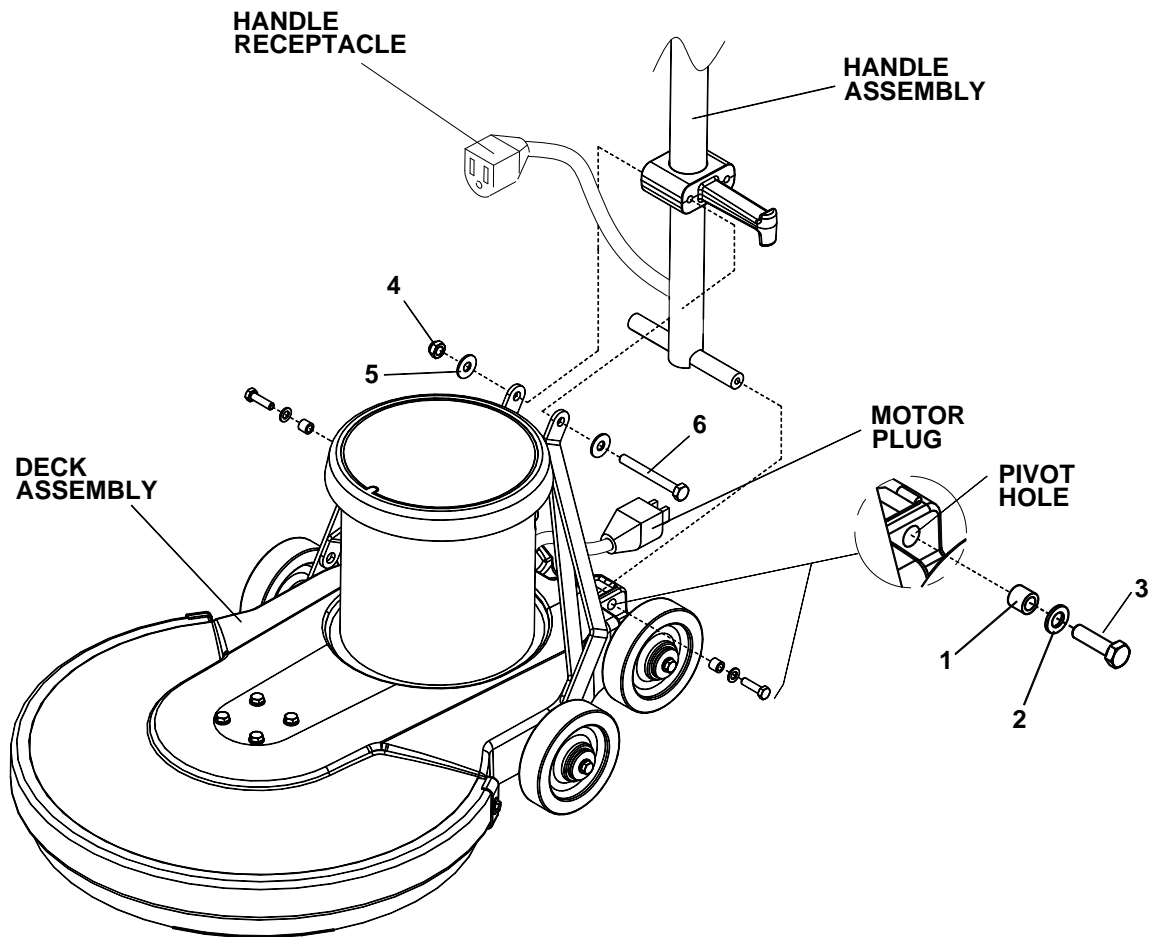

The machine is shipped with handle unassembled.

Follow these steps for installation:

1. Remove handle and deck assembly from carton.
2. Attach handle assembly to base using hardware kit (86219680 – PRV NO. 47331) (attached to handle in plastic bag) items 1, 2 and 3.
3. Remove bolt, nut and washers (items 4, 5 and 6) from lower block on handle assembly. Attach links as shown. Tighten bolt and nut securely, then back off 1/4 to 1/2 turn.
4. Check handle for movement up and down.
5. Plug motor cord into handle cord receptacle.

NOTE: The spacers (item 1) are required for the correct operation of the handle. The spacers are positioned completely inside the pivot holes in the casting, and are held in place by tightening the bolts and washers (items 2 and 3) against the spacer.

CONTROLS

1. **Safety Lock** – Prevents unintended operation of the machine.
2. **Switch Levers** – Turns machine on/off.
3. **Adjustment Handle** – Allows the handle to be adjusted to a comfortable operating position.

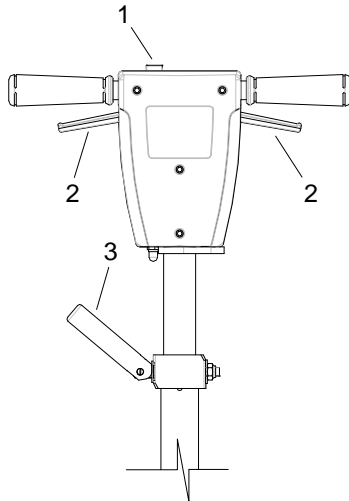

NOTE: It is incorrect to make it lock opposite from the way it was assembled by applying more force to the nut.

The pivot pin is off center in relationship to the axis of the handle. To adjust handle, tighten nut on handle while in the locked position. The handle is locked when the screw is to the outside of the machine and the flat on the opposite side of the handle is flush to the bracket.

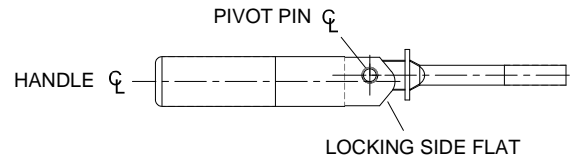

HANDLE HEIGHT ADJUSTMENT

NOTE: The handle is in the up, locked position from the factory.

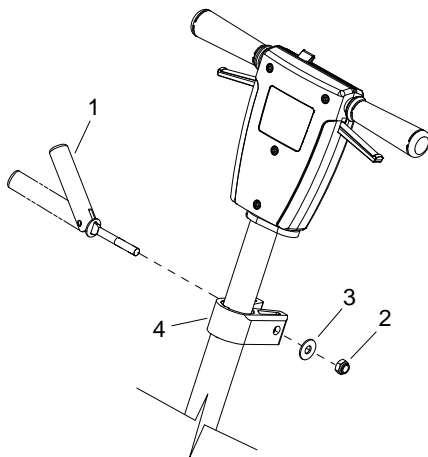

The handle adjust bar (1) for the polishers are individually preset at the factory for optimum locking efficiency and minimum effort of engaging. It should not be necessary to adjust the handle adjust bar unless the handle adjustment bar (1) the washer (3) and nut (2) have been disturbed.

OPERATION

MACHINE OPERATION

⚠ CAUTION:

For indoor use only.

⚠ CAUTION:

When using the pad, always keep the machine moving when in contact with the floor.

⚠ WARNING:

High starting torque. Hold machine firmly with both hands.

1. Ensure that the pad driver is in good shape. Install or change pad if necessary.
2. Plug the machine into a wall outlet as described in the grounding instructions.
3. Lower the handle by unlocking the adjustment handle and moving the handle into position. Relock the handle when it is in a comfortable position.

⚠ WARNING:

Insure that handle is locked in position before starting machine.

4. Push the safety lock forward, unlocking the switch levers.
5. With the safety lock forward, squeeze one or both of the switch levers, turning the machine on. (These levers can be operated independently of each other). The safety lock will not re-engage until both levers are released.
6. To stop the machine, release the switch levers.
7. Do not let machine rest on pad. When finished with the machine, return handle to the storage position.

NOTE: The machine is equipped with a circuit breaker to protect the motor in the event an overload condition occurs. The circuit breaker is located on the handle. Push the reset button to restart the machine. If the breaker trips again, correct the cause of overloading before proceeding.

DAILY MAINTENANCE

1. Inspect power cord for wear. To prevent electrical shock replace cords with frayed or cracked insulation immediately.
2. Place machine in the storage position.
3. Check pad condition. Change if soiled or torn.

PAD INSTALLATION

1. Lay machine back, exposing the under side.
2. Remove center lock by turning counter-clockwise.
3. Ensure pad is centered on pad driver. Pull pad to edge of pad driver in several directions to check for proper engagement.
4. Replace center lock by turning clockwise firmly compressing the center of the pad.

NOTES:

MAINTENANCE

MACHINE TROUBLESHOOTING

PROBLEM	CAUSE	SOLUTION
Machine will not run	Circuit breaker tripped in building.	Check and reset.
	Power switch failure	Test switch for continuity and replace if necessary.
	Tripped circuit breaker	Reset.
	Faulty power cord	Replace.
	Fuse in motor blown	Replace CAUTION: To reduce the risk of electrical shock, unplug the machine before opening fuse holder. Fuse will only open under extreme conditions. Investigate cause before replacing.
Electrical shock	Equipment not grounded	Follow grounding instructions exactly.
	Receptacle not grounded	Have an electrician inspect building's wiring.
	Internal wiring problem	Ensure that the machine wiring matches the appropriate wiring diagram. Replace any wires or components that are short circuiting.
Repeated circuit breaker tripping	Mechanical problem	Higher amp draws indicate a mechanical problem. Find the problem before using the machine.
	Faulty circuit breaker	Test circuit for continuity. Replace circuit breaker if necessary.
Excessive vibration	Pad not centered	Re-center pad.
	Damaged or unevenly worn pad	Replace pad. Do not rest machine on pad when not in use.
	Damaged pad driver	Replace.
Pad does not turn but motor is running	Belt is loose or broken	Adjust or replace belt.

MAINTENANCE

SERVICE SCHEDULE

MAINTENANCE	DAILY	MONTHLY
Check pad wear to prevent buildup of chemicals	*	
Check pad driver system for damage	*	
Check handles, switches, and knobs for damage	*	
Store with pad off the floor	*	
Check all bearings for noise		*
Check skirt/bumpers for damage and replace as necessary		*
Check overall performance of machine		*

DECK

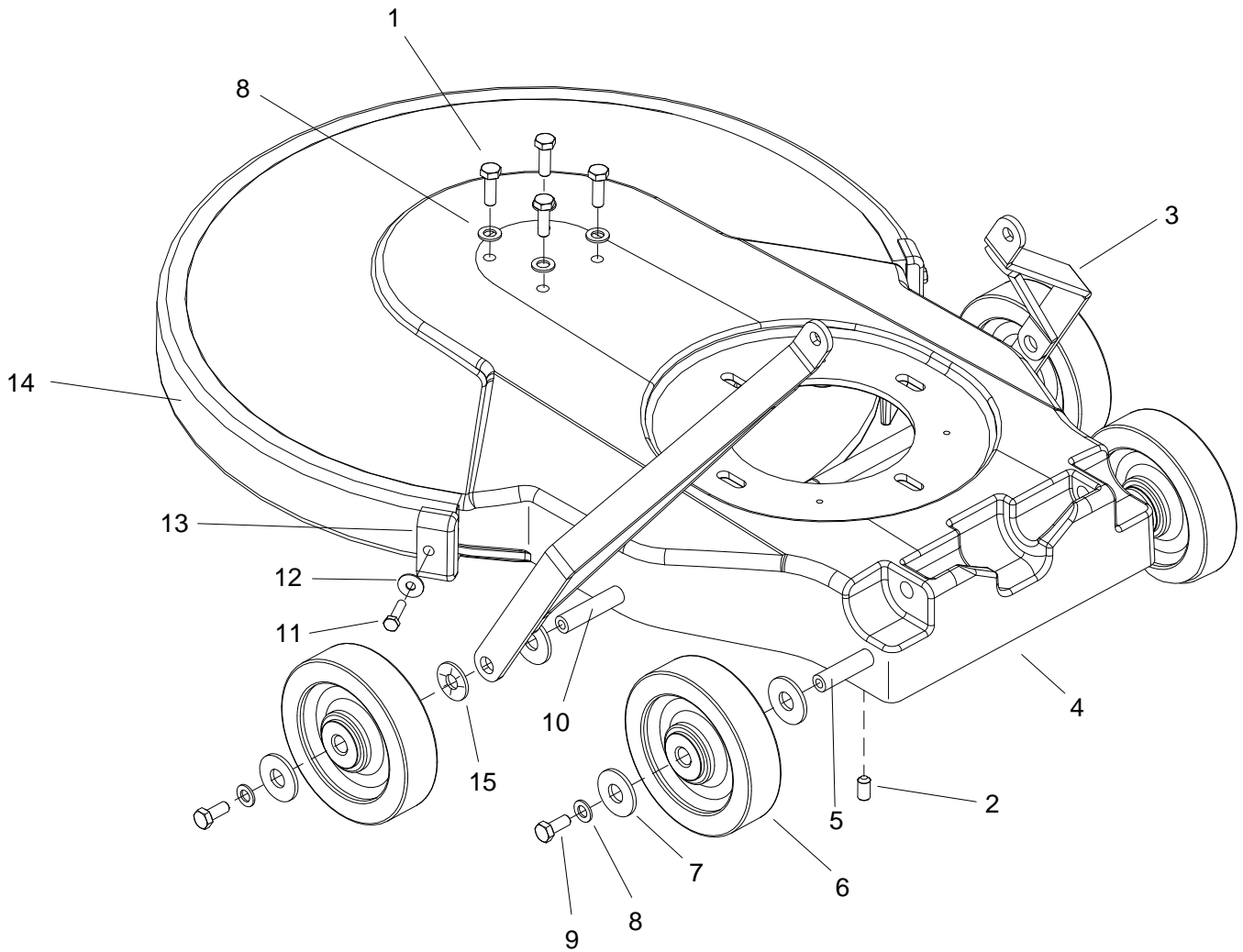

DECK

REF	PART NO.	PRV NO.	QTY	DESCRIPTION	SERIAL NO. FROM	NOTES:
1	86288730	70184	4	SCR, M8 X 25HHCS		
2	86288740	70709	2	SET SCR, 8MMX1.25X8MM CUP PT		
3	86215460	140397	2	BRACKET, HANDLE LINK		
4A	86217630	29229BLU	1	DECK, 20 IN BURNISHER, BLUE		
4B	86288990	29229GRY	1	DECK, 20 IN BURNISHER, GRAY		
5	86214930	03111	1	AXLE, MAIN POLISHER		
6	86226020	89206	4	WHEEL, 5D X 1.25 X 13MM ID GRY		
7	86225720	87203	8	WASHER, 14MM ID X 36MM OD		
8	86137280	87054	8	WASHER, M8 FLAT DIN125A PLT		
9	86136640	70262	4	SCR, M8-1.25 X 20 HHMS PLTD		
10	86214950	03116	1	AXLE, MAIN BURNISHER		
11	86276570	70691	2	SCR, M6 X 25 HHCS		
12	86137340	87211	2	WASHER, M6 FLAT		
13	86216600	27871	2	CAP, EXTRUSION		
14	86216360	14423	1	BUMPER, EXTRUSION 42.6 IN		
15	86222270	57276	2	NUT, PUSH FLAT RD .51 ID		

DRIVE/PAD LOCK

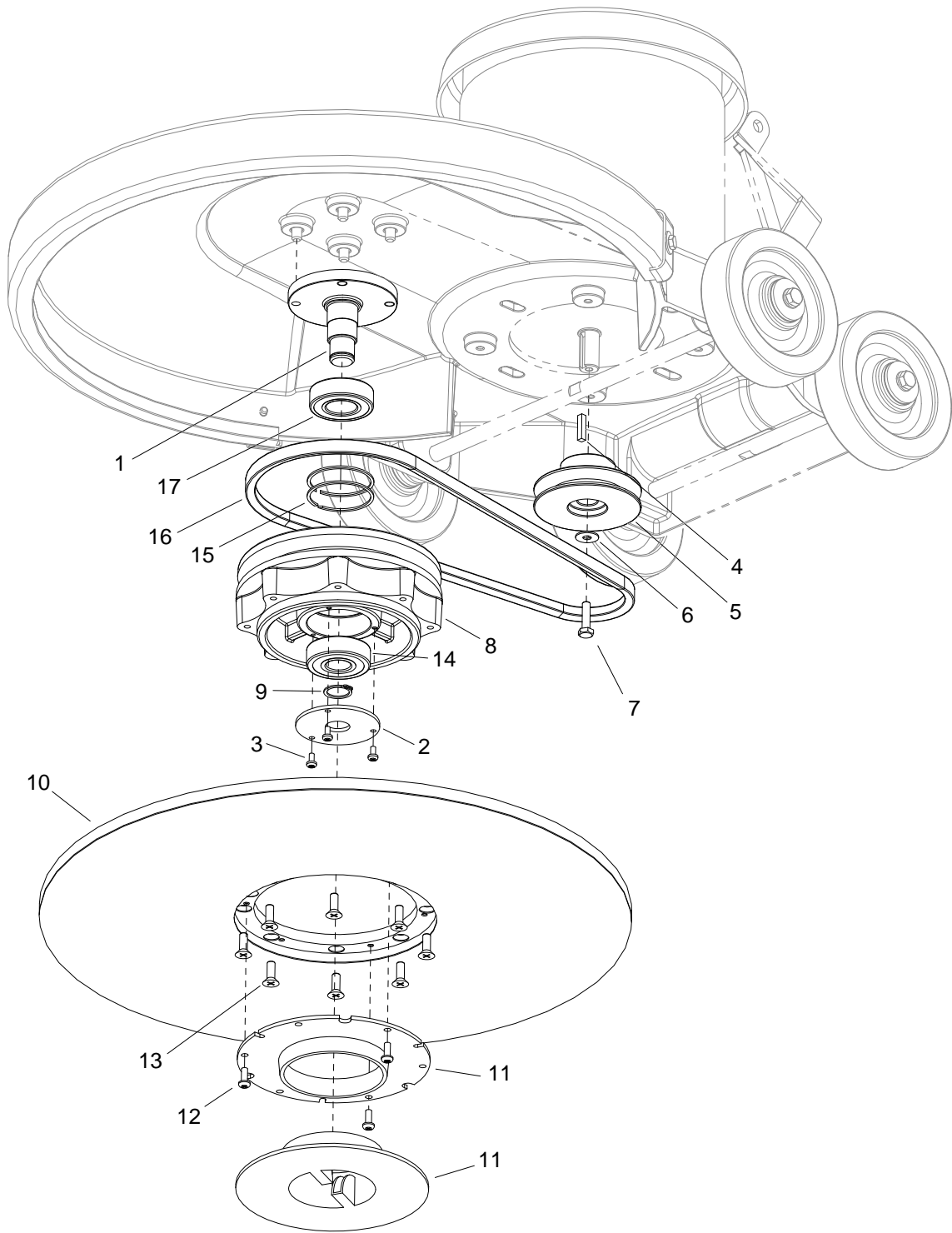

DRIVE/PAD LOCK

REF	PART NO.	PRV NO.	QTY	DESCRIPTION	SERIAL NO. FROM	NOTES:
1	86214940	03115	1	AXLE, PAD DRIVER		
2	86217510	27913	1	COVER, BEARING		
3	86276730	70719	3	SCR, M4 X 8MM PPHMS		
4	86004820	48041	1	KEY, 3/16 SQ X 7/8 CRS		
5	86223280	64106	1	PULLEY, .625 X 3.45		
6	86225730	87218	1	WASHER, M6 (20.5OD X 1.67) PLT		
7	86275570	70505	1	SCR, 1/4-20 X 1.00 HHCS GR5		
8	86223290	64107	1	PULLEY, BURNISHER		
9	86223470	67449	1	RING, 20M EXTERNAL SNAP		
10	86222480	66426	1	PAD DRIVER, 20 IN BURNISHER FLEX		
11	86246740	51353	1	LOCK, PAD DRIVER BLUE		
12	86276740	70720	3	SCR, #10 X 3/8 PPHST TYPE B		
13	86006670	70201	8	SCR, 1/4-20 X 3/4 FHCS		
14	86223970	09133	1	BEARING, 20MM X 52MM		
15	86223480	67450	2	RING, 52MM INTERNAL SNAP		
16	86215330	14424	1	BELT, DRIVE 38 IN		
17	86223980	09134	1	SEALED BALL BEARING, 25MM X 52MM		

ELECTRICAL

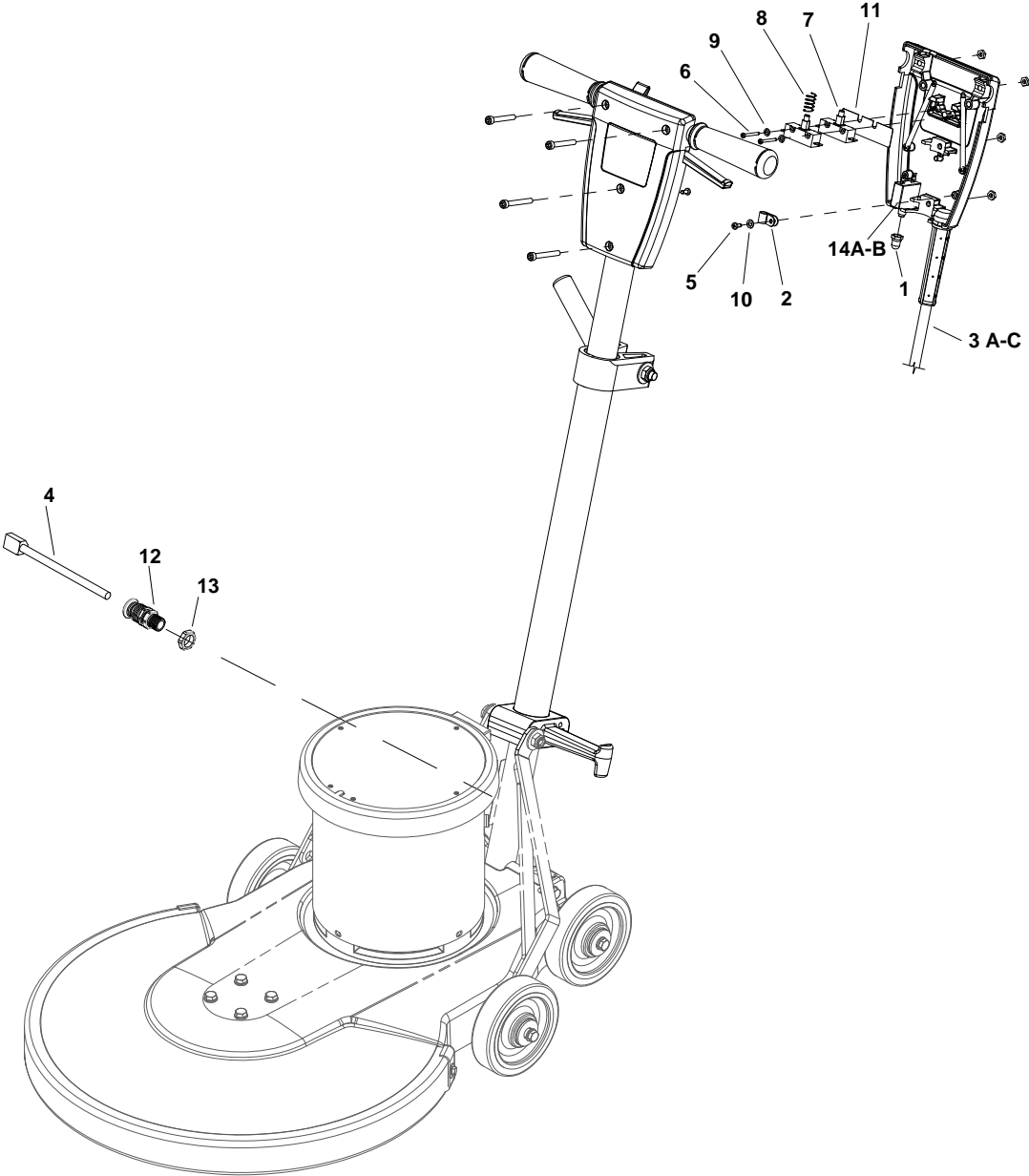

ELECTRICAL

REF	PART NO.	PRV NO.	QTY	DESCRIPTION	SERIAL NO. FROM	NOTES
1	86002010	14942	1	BOOT, 3/8 CIRCUIT BREAKER		
2	86198450	20005	1	CLAMP, 5/16 NYLON		
3A	86216950	23212	1	CORD SET, EURO 1.5MM X 75 BLK		LB1500IE
3B	86234140	23254	1	CORD SET, 14/3 ST C 75' YLW		LB1500IA
3C	86234140	23154	1	CORD SET, 14/3 ST X 75FT, YLW		LB1500, U1500,SPT1500
4	86216920	23206	1	CORDSET, 14/3 X 52 IN, SJT, BLK		
5	86268450	70689	1	SCR, M4.8 X 10 HHTF TYPE B		
6	86136780	70801	2	SCR, M3.5 X 40 PHTF		
7	86007110	72123	2	SWITCH, 25A SPST 125-250V SNAP		
8	86224750	73993	1	SPRING, COMP, .48OD X .91		
9	86137290	87057	2	WASHER, M4 LOCK		
10	86137330	87208	1	WASHER, M5 LOCK		
11	86215140	140674	1	BARRIER SHEET		
12	86224930	730012	1	STRAIN RELIEF, 14/3 STRAIGHT		
13	86224300	730021	1	SPACER, POLISHER HANDLE		
14A	86312460	-	1	BREAKER, 14A VDE CIRCUIT		120V
14B	86291460	-	1	BREAKER, 11A VDE CIRCUIT		230V

HANDLE

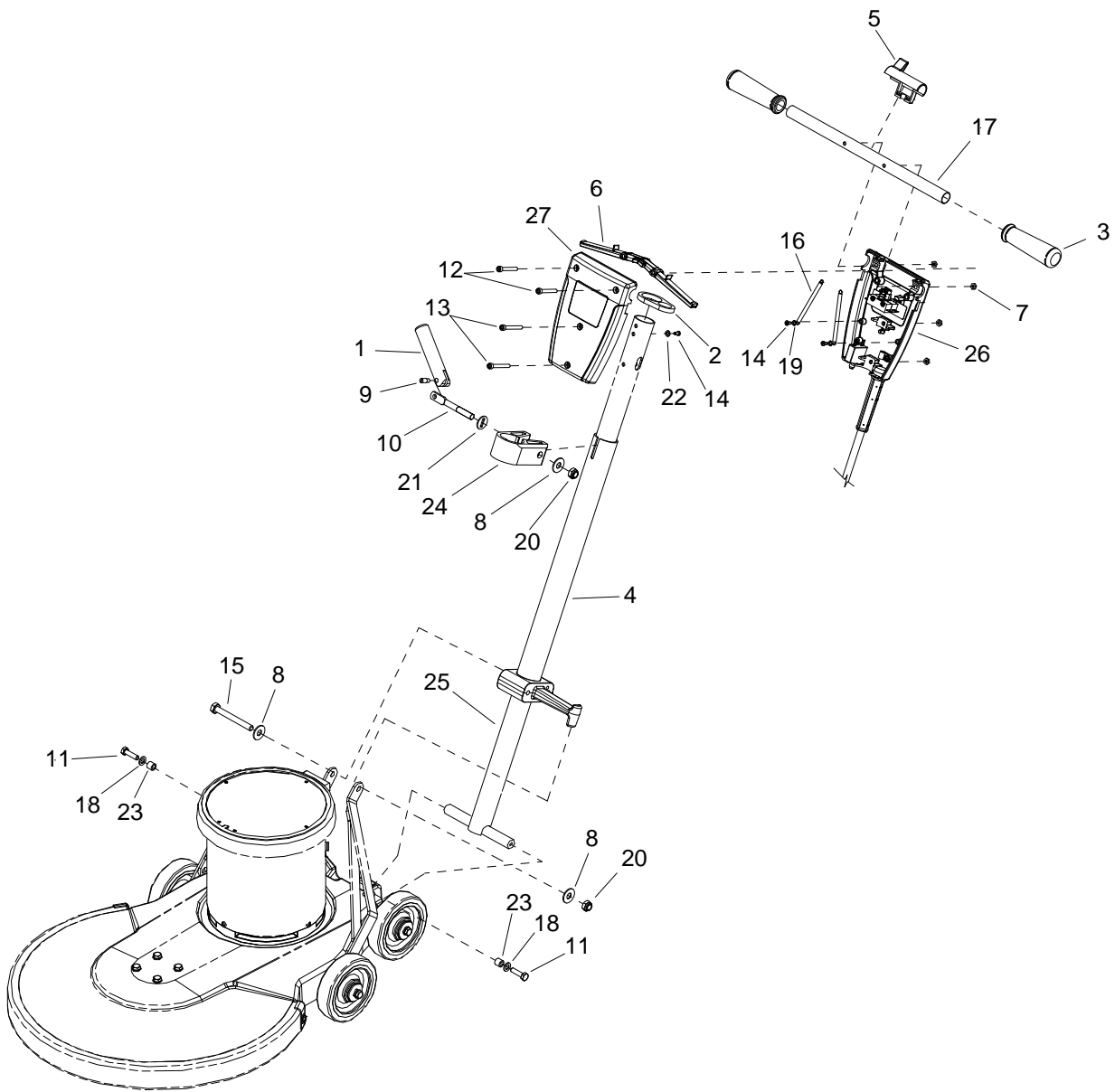

HANDLE

REF	PART NO.	PRV NO.	QTY	DESCRIPTION	SERIAL NO. FROM	NOTES
1	86215130	14344	1	BAR, HANDLE ADJUST		
2	86216370	14434	1	BUMPER, BURNISHER HANDLE		
3	86004070	36196	2	GRIP, POLISHER HANDLE		
4	86311800	-	1	TUBE ASSY, HANDLE ADJ.		
5	86005150	51326	1	LOCK, SAFETY HANDLE		
6	86005160	51327	2	LEVER, SWITCH		
7	86136350	57274	4	NUT, M6 HEX FINISH		
8	86136360	57275	2	NUT, M10 X 1.5 HEX NYLOK PLTD		
9	86222560	66334	1	PIN, PIVOT, HANDLE ADJUST		
10	86223550	67430	1	ROD, HANDLE ADJUST		
11	86274230	70135	2	SCR, M8 X 30 HHMS		
12	86136670	70686	2	SCR, M6 X 45 SHCS, BLK		
13	86136680	70687	2	SCR, M6 X 50 SHCS, BLK		
14	86288450	70689	4	SCR, M4.8 X 10 HHTF TYPE B		
15	86136720	70701	1	SCR, M10 X 1.50 X 90 HHCS PLTD		
16	86224740	73990	2	SPRING, EXT, .50D X 3.5L		
17	86225370	78437	1	TUBE, GRIP HANDLE		
18	86137280	87054	2	WASHER, M8 FLAT DIN15A PLT		
19	86279080	87058	2	WASHER, M4 FLAT DIN125A PLT		
20	86010720	87086	3	WASHER, M10 X 30 PLTD		
21	86225710	87202	1	WASHER, BEARING (HANDLE ADJ)		
22	86137330	87208	2	WASHER, M5 LOCK SHAKEPROOF PLTD		
23	86224290	730008	2	SPACER, .317ID X .50D X .44LG		
24	86310950	-	1	CLAMP, HANDLE		
25	86218500	38316	1	HANDLE, BRNSHR EXTND		
26	86311810	-	1	HOUSING, POLSHR HANDLE RR, CB		
27	86311820	-	1	HOUSING, POLSHR HANDLE FRT,CB		

MOTOR

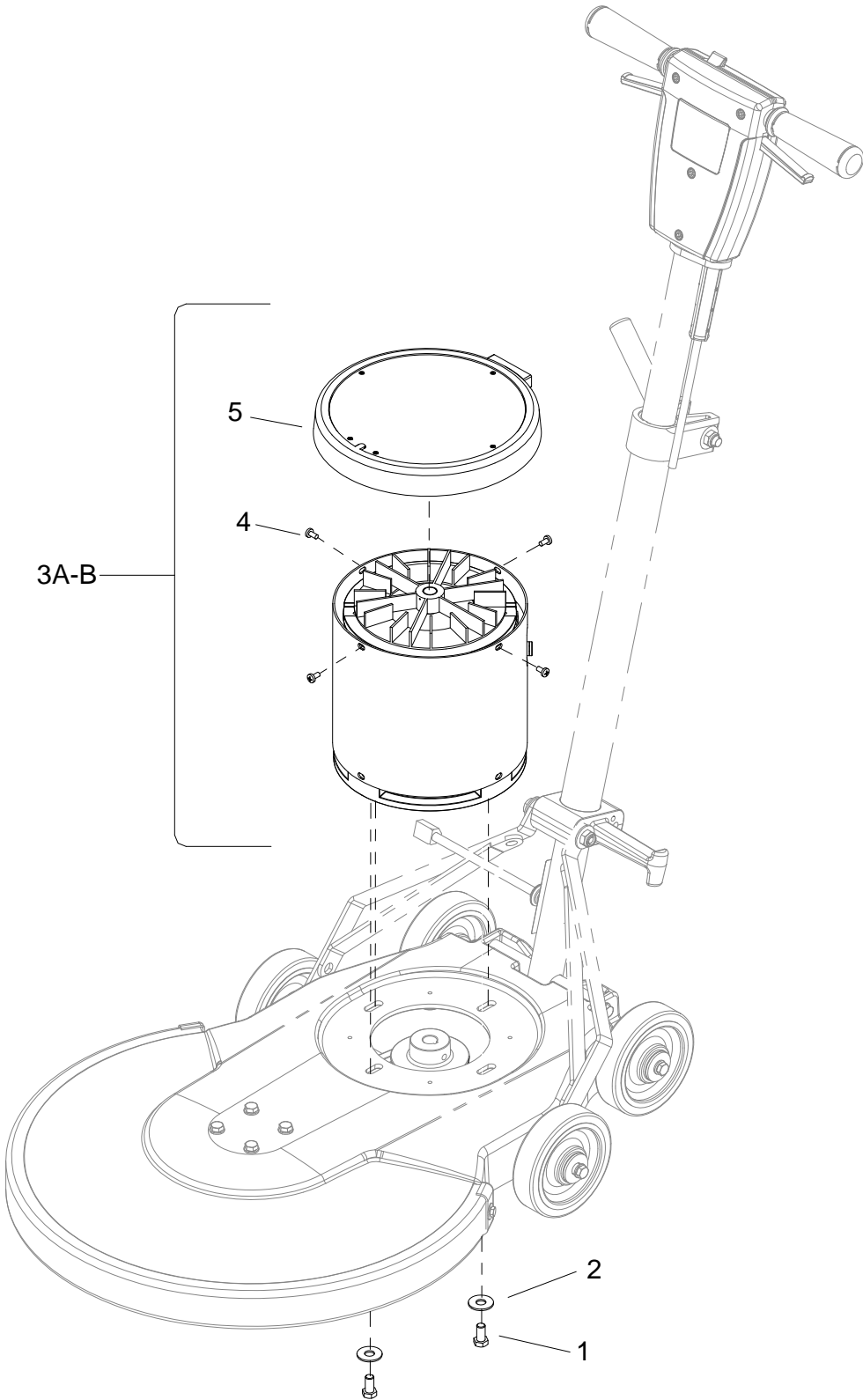

MOTOR

REF	PART NO.	PRV NO.	QTY	DESCRIPTION	SERIAL NO. FROM	NOTES:
1	86006920	70507	4	SCR, 3/8-16 X 3/4 HHCS GR5 PLT		
2	86010720	87086	4	WASHER, M10 X 3 PLTD		
3A	86312240	-	1	MOTOR, 115V 1.5HP 3000RPM		
3B	86312230	-	-	MOTOR, 230V 1.5HP 3000RPM		
4	86223680	70700	8	SCR, M5 X .8 X 10MM PHMS BLK		
5	86217500	27892	1	COVER ASM, MOTOR 1.75HP		

WIRING-120V

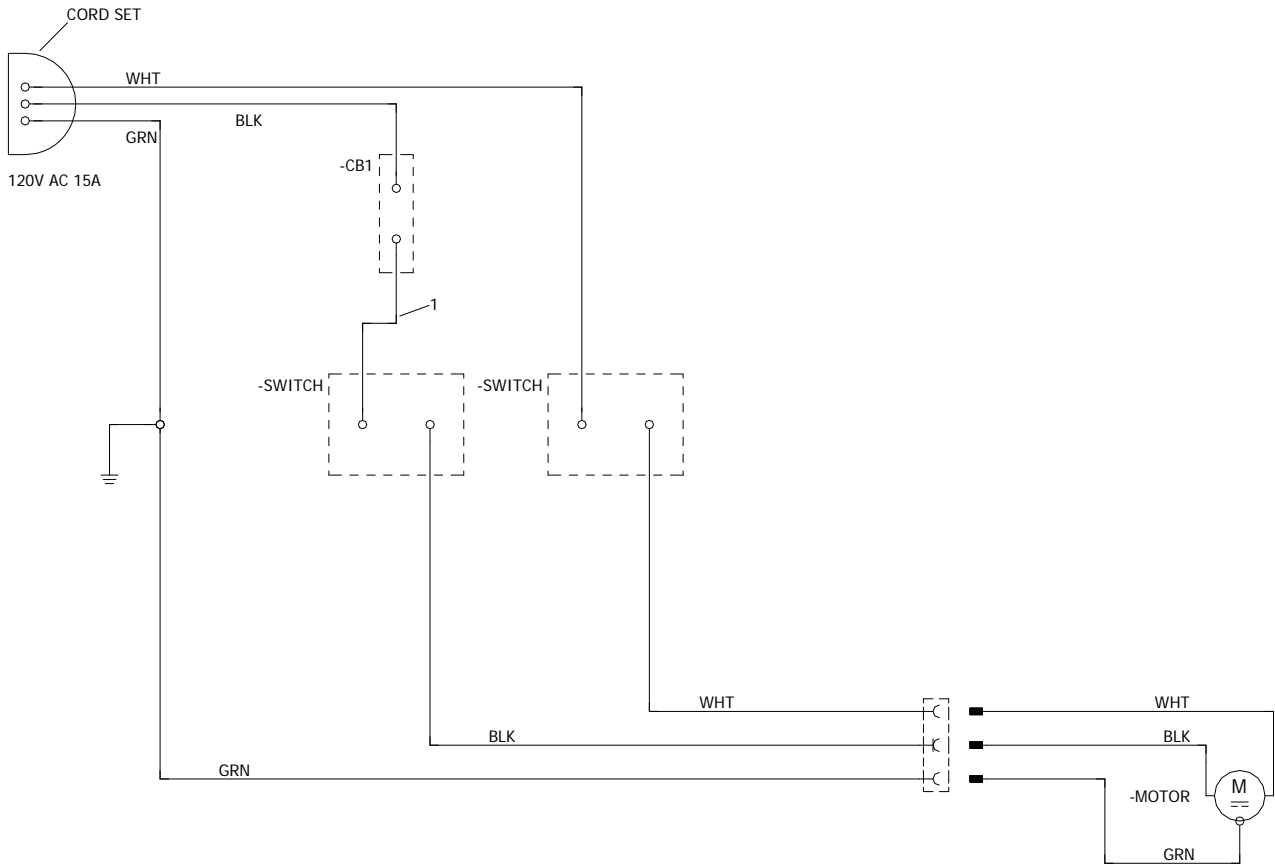

REF	PART NO.	PRV NO.	QTY	DESCRIPTION	SERIAL NO. FROM	NOTES:
1	86311830	-	1	WIRE, 125MM, BLK/14, 76029X76029		

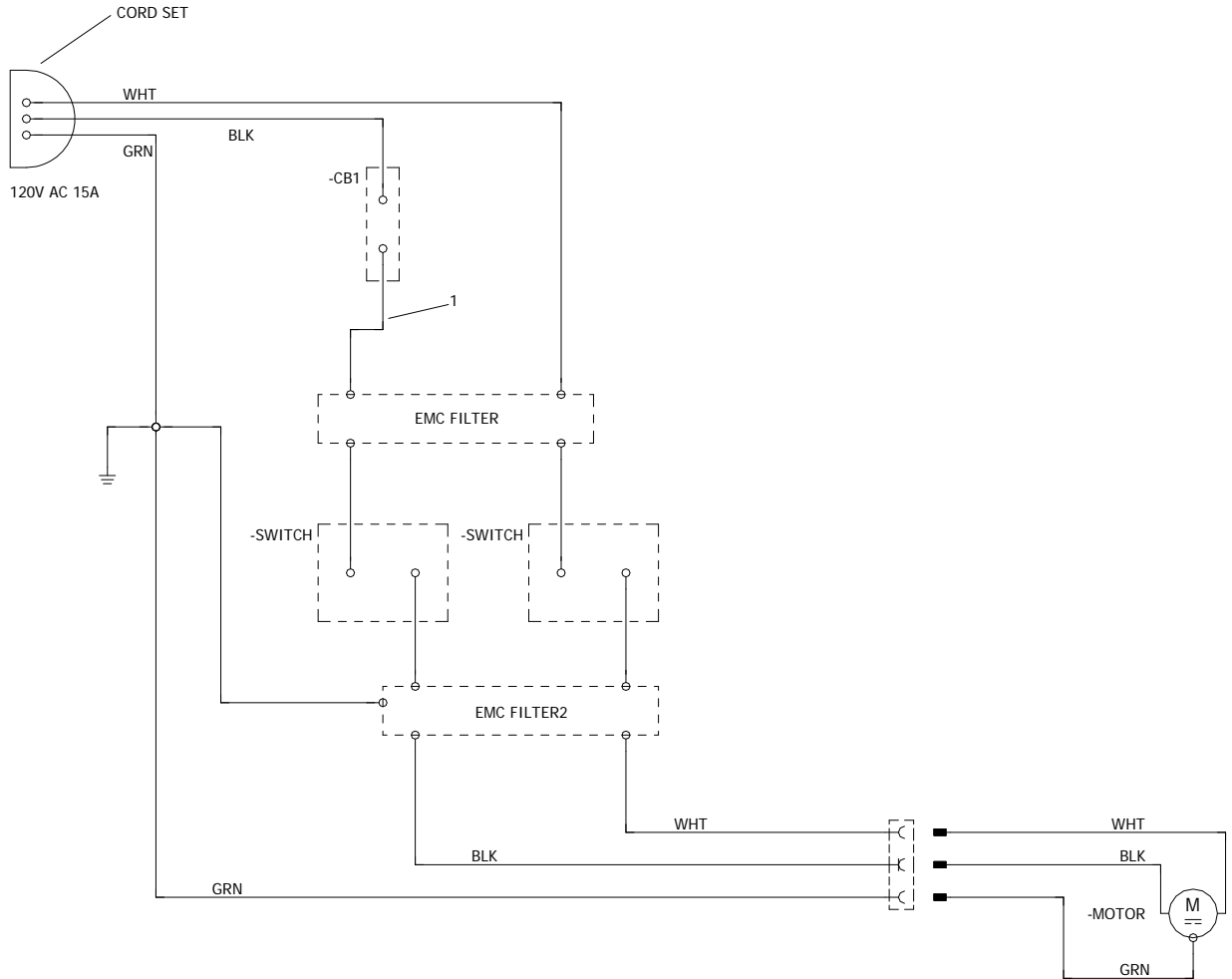

REF	PART NO.	PRV NO.	QTY	DESCRIPTION	SERIAL NO. FROM	NOTES:
1	86311830	-	1	WIRE, 125MM, BLK/14, 76029X76029		

SUGGESTED SPARE PARTS

PART NO.	PRV NO.	DESCRIPTION	SERIAL NO. FROM	NOTES:
86225710	87202	WASHER, BEARING (HANDLE ADJ)		
86224740	73990	SPRING, EXT, .5OD X 3.5L		
86224750	73993	SPRING, COMP, .48 OD X .91L		
86007110	72123	SWITCH, 25A SPST 125-250V SNAP		
86215130	14344	BAR, HANDLE ADJ		
86222560	66334	PIN, PIVOT ,HANDLE ADJ		
86223550	67430	ROD, HANDLE ADJ		
86291460	-	BREAKER, 11A VDE CIRCUIT		230V
86312460	-	BREAKER, 14A VDE CIRCUIT		120V
86223390	67488	RECTIFIER, 50A 600V BRIDGE		LB1500, U1500, SPT1500
86001820	14404	BRUSH SET		120V
86001720	140785	BRUSH SET (SET OF 4)		230V
86003660	34378	FUSE		
86003670	34379	FUSE HOLDER		
86216600	27871	CAP, EXTRUSION		
86216360	14423	BUMPER, EXTRUSION 44.30 IN		
86222480	66426	PAD DRIVER, 20IN BURNISHER FLEX		
86246740	51353	LOCK, PAD DRIVER BLUE		
86223970	09133	SEALED BALL BEARING, 20MM X 52MM		
86223980	09134	SEALED BALL BEARING, 25MM X 52MM		
86217510	27913	COVER, BEARING		
86215330	14424	BELT, DRIVE 38 IN		

NOTES: