



KENT

PARTS MANUAL

FOR COMMERCIAL USE ONLY
EXTRACTOR

SelecTrac KX-15SCST

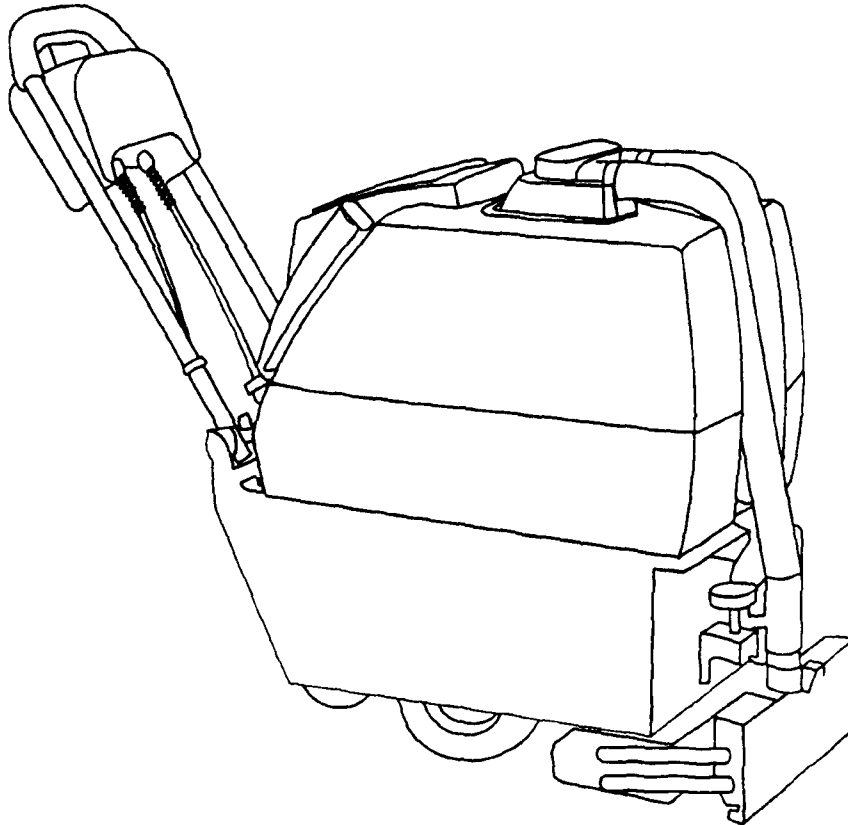

EDITION 1
JULY 1996
083435

TABLE OF CONTENTS

RECOMMENDED SPARE PARTS	1
SPECIFICATIONS	2
TANKS ASSEMBLIES	3-4
HANDLE ASSEMBLY	5-6
BASE ASSEMBLY	7-8
BRUSH AND HEAD ASSEMBLY	9
NOZZLE ASSEMBLY	10
WIRING DIAGRAM	11

RECOMMENDED SPARE PARTS

Recommended spare parts should be ordered and stocked to avoid possible down time in case of failure, breakage, or normal wear.

PART NO.	DESCRIPTION	QUANT.
1 057448	NOZZLE,TIP—95 DEG. W/FILTER	2
2 035533	ASM,WTR PUMP—65PSI,115V,15ST	1
3 035152	ASM,BRUSH—2.25OD CYL,13.465L	1
4 027142	SWITCH,RKR—DPST,16A,125/250V	2
5 056544	BOOT,RUBBER—PRO FOR SW027142	3
6 026751	CIRCUIT BREAKER—10AMP	1
7 027107	SWITCH,RKR—DPDT,13A,125V,OFF	1
8 056546	BOOT,RUBBER—PRO FOR CB 027141	1
9 026211	FUSE—1A,SLOW BLOW	2
10 055114	BELT,V—6V'S, 19.00 PITCH LG	1

SPECIFICATIONS

SOLUTION TANK CAP.(gal/l)	7.0/26.5
RECOVERY TANK CAP.(gal/l)	8.0/30.2
OPERATING VOLTAGE	115/1/60
BRUSH MOTOR HP	1/3
BRUSH MOTOR HP (WATTS)	464(SF LOAD)
BRUSH MOTOR RPM	1725
VACUUM MOTOR TYPE	1.8PHP,2-STG BP
WATER LIFT (H2O-IN)	87.2 (SEALED)
CFM (APPROX)	92.0
BRUSH DRIVE	MULTI-V6 BELT
BRUSH DIA. (IN/CM)	2.25/5.72
BRUSH RPM	1208
BRUSH LENGTH (IN/CM)	13.47/34.2
WATER PUMP DESIGN	SELF PRIMING,DEMAND
WATER PUMP PRESSURE (PSI/BAR)	65/4.48
PUMP FLOW RATE (gpm/l)-OPEN	1.40/5.30
SPRAY NOZZLE DESIGN	QD
NOZZLE FLOW RATE (gpm/l)	0.56/2.12
NOZZLE TIP SPRAY ANGLE	95 DEG
WHEELS (IN/CM)	TWO 8/20.3 DIA
POWER CORD LENGTH (FT/M)	50/15.24
POWER CORD SIZE	14-3 SJTW-A
HEIGHT UNCOLLAPSED (IN/CM)	40.0/101.6
HEIGHT COLLAPSED (IN/CM)	15.75/40.0
WIDTH @ OFFSET (IN/CM)	17.0/43.2
LENGTH - UNCOLLAPSED (IN/CM)	35.0/88.9
COLLAPSED LENGTH (IN/CM)	32.0/81.3
WEIGHT (LBS/KG)	99/44.9
SHIPPING WEIGHT (LBS/KG)	118/53.6
WEIGHT - KNOCKED DOWN (LBS/KG)	21/9.5 REC TANK/SOL TANK 78/35.4 BASE
CLEANING PATH (IN/CM)	15.0/38.1

TANKS ASSEMBLIES

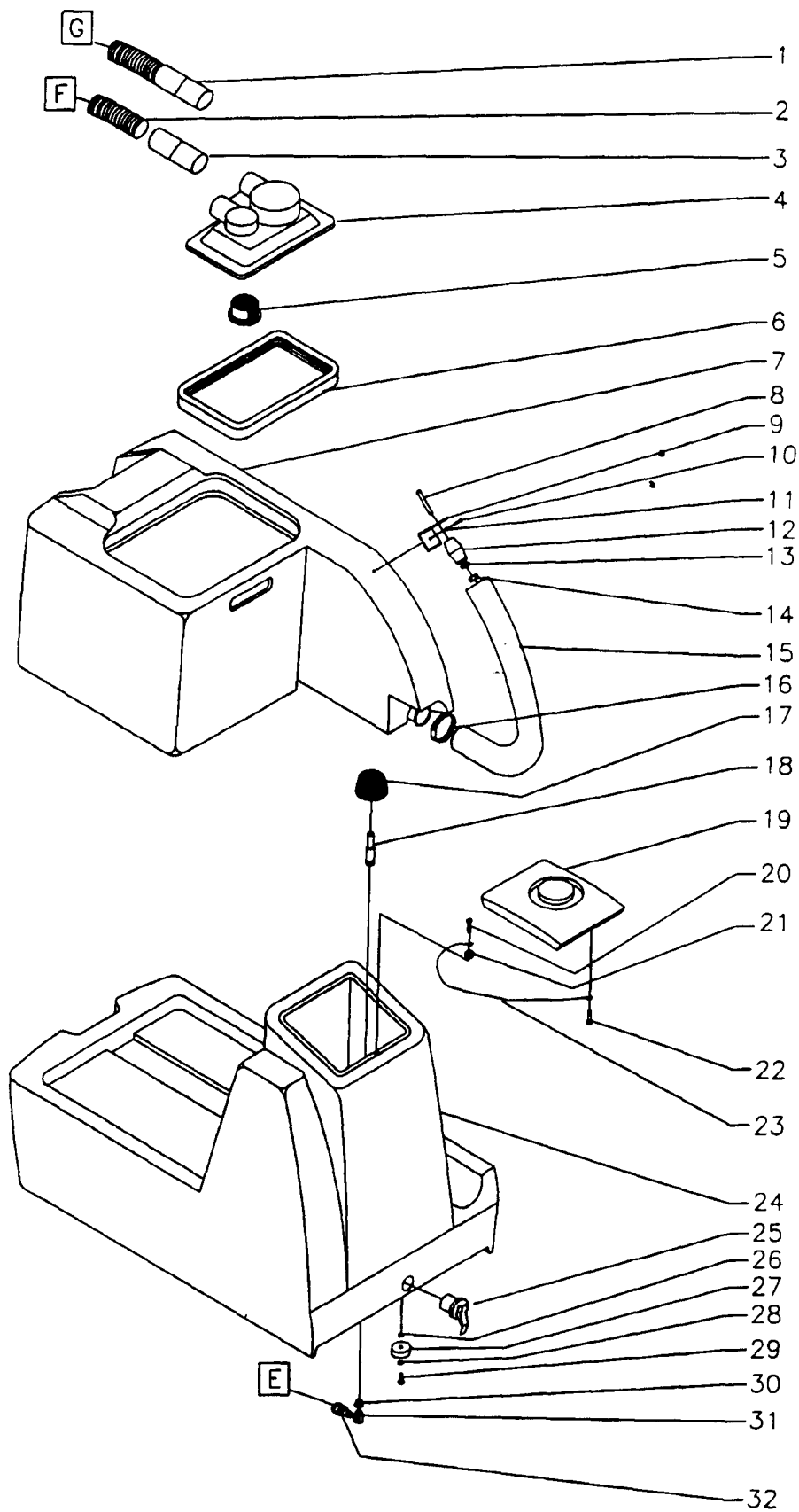

TANKS ASSEMBLIES PARTS LIST

DET.	PART NO.	DESCRIPTION	QUANT.
1	035164	ASM,1-1/2"HOSE W/2 CUFFS X 13	1
2	035165	ASM,1-1/2"HOSE W/1 CUFF X 25	1
3	055989	CUFF,HOSE—1.5,BLACK	1
4	035237	LID,TRANSPARENT—WARNING LABEL	1
5	056482	FILTER,CAP—VAC INTAKE,EXTR	1
6	056379	GASKET,FOAM—EXTR.RECOVERY	1
7	057530	TANK,REC—MACH,KX15SCST,KT	1
8	005625	SCR MACH PAN HD 10-24,2.50L,SS	1
9	057055	BRKT,ALUM—.125,FORMED,BLACK	1
10	002459	SCR CAP HEX HD .250-20X.500LSS	1
11	004536	WSHR LK .267ID.510OD.028T,SS	1
12	056456	STOPPER,RUBBER—7/8DIA,EXTR	1
13	004531	WSHR FLT .281ID.625OD.080T,SS	1
14	003469	NUT,HEX LOCK— 10-24,TPLK,SS	1
15	056533	TUBE,RUBBER—1.250DX1.01DX13.5	1
16	049082	CLAMP,HOSE—1.50 MAX DIA,WORM	1
17	057209	LINE STRAINER—80 MICRON,S.S.	1
18	051207	ADPTR,PP-HS—1/2 MPTX3/8HS,PLS	1
19	057585	LID,SOL—MACH,EXTR	1
20	005511	SCR MACH FLAT HD 10-24X.5LSS	1
21	003406	NUT,HEX— 10-24,SS	1
22	002416	SCR TPG F PAN HD 10-8 X.375L	1
23	056819	WIRE ROPE—.062DIA X 12.00L	1
24	057582	TANK,SOL—MACH,KX15SCST,KT	1
25	054583	PLUG,EXPANSION—.75DIA,SNAPTIE	1
26	S50762	WSHR LK .250ID EXT	1
27	057528	SPCR,NYLON—.375IDx1.00,.375LG	1
28	002278	WSHR LK .262ID.489OD.062TSPLT	1
29	002259	SCR MACH RD HD .250-20X1.00L	1
30	006104	BSHG,PIPE—1/2 MPTX1/4 IPT,BRS	1
31	050199	ELBOW,PIPE—1/4 MPTX1/4IPT	1
32	050815	COUPLING,QUICK DISCONNECT—BRS	1

Additions:

4 057689 Float Assy

~~4 057692 Coupler~~

HANDLE ASSEMBLY

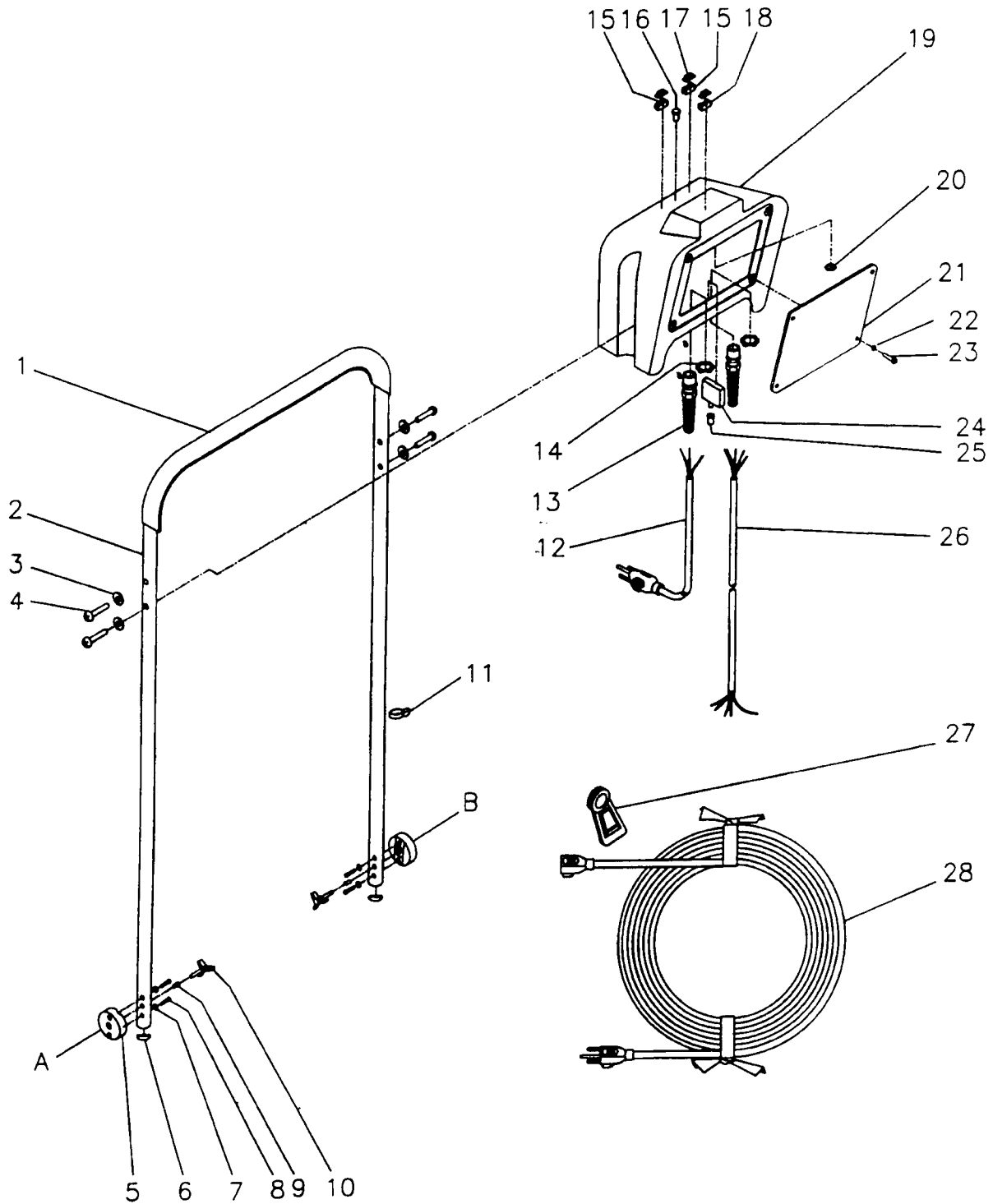

HANDLE ASSEMBLY PARTS LIST

DET.	PART NO.	DESCRIPTION	QUANT.
1	057586	GRIP,FOAM—.875X.250WLX14.00"	1
2	057516-24	HANDLE—.875 DIA,GRAY,KX15SCST	1
3	004253	WSHR LK .204ID.410OD.025T EXT	4
4	002497	SCR MACH PN HD 10-32X1.00,BLK	4
5	057514-24	GEAR,RATCHET—PNTD GRAY,15SCST	2
6	057554	PLUG,PIPE—.875TUBE,BLK	2
7	004254	WSHR LK .267ID.510OD.028T EXT	4
8	002496	SCR MACH RD HD .250-20X1.25L.B	4
9	057550	SPCR,STL—.397IDX.563ODX0.20LG	2
10	057456	KNOB,PLSTC—.250-20,3 PT,BLK	2
11	056612	CLIP,CORD—EXTR,PLATED	1
12	026010	CORD,POWER—14/3SJTW-A,2FT,YEL	1
13	027003	BSHG,STRAIN RLF—.170-.470	2
14	006108	NUT,SPECIAL—.500 PIPE,HEX LOC	2
15	027142	SWITCH,RKR—DPST,16A,125/250V	2
16	026207	LIGHT,INDTR—GRD,120V,UL/CSA	1
17	056544	BOOT,RUBBER—PRO FOR SW027142	3
18	027107	SWITCH,RKR—DPDT,13A,125V,OFF	1
19	057458-1	PANEL,CONTROL—MACH,KX15SCST	1
20	057547	WSHR,PUSH—LIGHT 026207,026208	1
21	035498	ASM,GASKET & COVER—KX15SCST	1
22	004527	WSHR,FLT .203ID,.500OD,STL BLK	4
23	005609	SCR MACH PAN HD 10-32X.5,BLK	4
24	026751	CIRCUIT BREAKER—10AMP	1
25	056546	BOOT,RUBBER—PRO FOR CB 027141	1
26	026210	CORD—16/5 SJTW-A, 51" YEL	1
27	056550	CLEAT,STRAIN RELIEF—EXTR'S	1
28	026015	CORD,POWER—14/3SJTWA,50FT,YEL	1

BASE ASSEMBLY

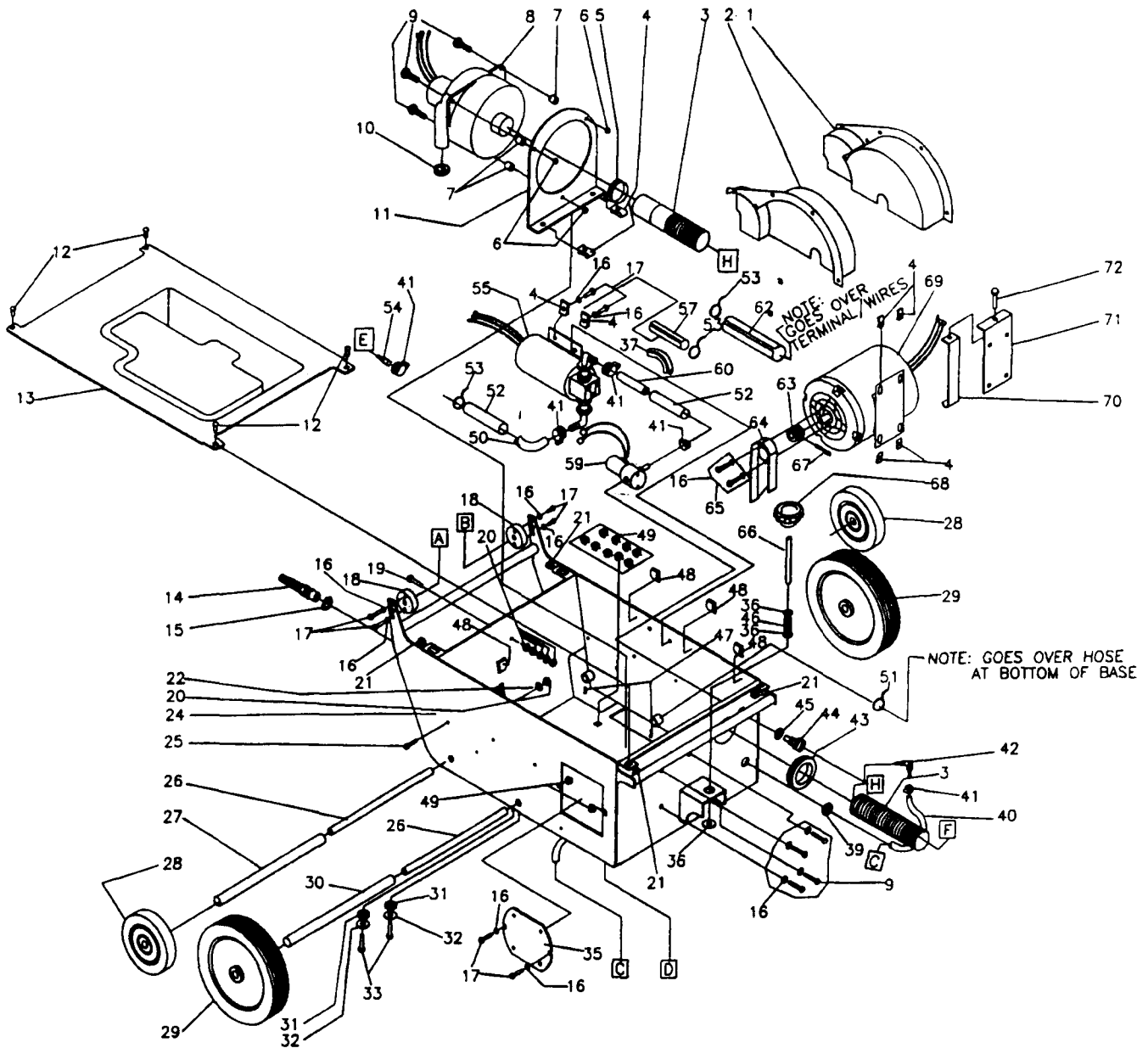

BASE ASSEMBLY PARTS LIST

DET.	PART NO.	DESCRIPTION	QUANT.	DET.	PART NO.	DESCRIPTION	QUANT.
1	056415	COVER,WHEEL—RIGHT SIDE,EXTR	1	36	004539	WSHR FLT .406ID1.000D.071T,SS	3
2	056414	COVER,WHEEL—LEFT HAND,EXTR	1	37	057552-1	TUBE,PLSTC— .375IDX9.00LG,SLIT	1
3	035165	ASM,1-1/2"HOSE W/1 CUFF X 25	1	39	052338	GROM— .621ID,.75MHD,.125PA	1
4	003429	NUT,SPEED,U— .250-20,.58X1.125	8	40	057580-1	TUBE,VINYL— .375X.625X21,R,BLK	1
5	046688	CLAMP,HOSE—1.75 MAX DIA,WORM	1				
6	005479	NUT,HEX LOCK— .250-20,NYLOC,ZN	3	41	051581	CLAMP,HOSE— .625 MAX DIA,WORM	5
7	046309	SPACER,PHEN— .250X.500,.500L	3	42	034776	ASM,COUPLER & ADAPTER—EXTR	1
8	026232	MTR,VAC—115V,2STG,W/TERM	1	43	053901	GROM—1.93ID,2.43MHD,.125PA	1
9	002454	SCR CAP HEX HD .250-20X1.50L	7	44	050815	COUPLING,QUICK DISCONNECT—BRS	1
10	056565	GASKET,DISCHARGE—VAC MTR,KX15	1	45	004524	WSHR LK .675ID.777OD.031T,INT	1
				46	056483	SPRING,COMP .432D 1.50L.054WD	1
11	055109	BRKT,VAC MTR—ALUM	1	47	004352	PIN,LOCK— .125 DIA WIRE	2
12	001334	SCR MACH FLAT HD 10-24X.750L	4	48	G721213	CLAMP WIRE/HOSE—	3
13	057452	LID,BASE—MOLDED,KX15SCST	1	49	005612	NUT,SELF-RETAINING— .250-20	11
14	027003	BSHG,STRAIN RLF— .170-.470	1	50	057580-3	TUBE,VINYL— .375X.625X14,R,BLK	1
15	006108	NUT,SPECIAL— .500 PIPE,HEX LOC	1				
16	004536	WSHR LK .267ID.510OD.028T,SS	12	51	050759	STRAP,TIE,ELEC—12.00L,NYLON	1
17	002400	SCR MACH PAN HD .250-20X.625L	8	52	057581-1	TUBE,PVC— .750X.875X5.75 CLEAR	2
18	057515-24	GEAR,RATCHET—PNTD GRAY,15SCST	2	53	047085	STRAP,TIE,ELEC— 5.50L,NYLON	7
19	005615	SCR MACH RD HD 10-24X1.50L,SS	1	54	050814	MALE COUPLER PLUG	1
20	001519	NUT,KEPS—10-24,ZN PLT	15	55	035533*	ASM,WTR PUMP—65PSI,115V,15ST	1
				57	057552	TUBE,PLSTC— .375IDX6.00LG,SLIT	1
21	003453	NUT,SELF-RETAINING—10-24	4	59	035178-1	ASM,VALVE—FITTING,TERM,120V	1
22	224012	WSHR FLT .219ID.500OD.065T STL	10	60	057580-2	TUBE,VINYL— .375X.625X6.5,R,BL	1
24	035526-24	WDMT,BASE—PNTD GRAY,KX15SCST	1				
25	004543	SCR MACH PAN HD 10-24X.625L,BL	10	62	057553	TUBE,PLSTC—1.125IDX7.00LG,SLT	1
26	056553	AXLE,WHEEL— .500DX12.79,KX15SC	2	63	056606	PULLEY,GROOVED—6GRV,ALUM,.875	1
27	056933	PIPE,PLSTC—1/2"NOM X 9.50	1	64	057592	BELT/MOTOR COVER—MOLD/MACH	1
28	048058	WHEEL—5.00DIA,.504BORE,1.12HB	2	65	002240	SCR MACH FLAT HD .250-20X.500L	2
29	052893-1	WHEEL—GRAY/BLK,5RIB,8.00OD	2	66	056444	STUD,CONT THD— .375-16X5.000L	1
30	056934	PIPE,PLSTC—1/2"NOM X 8.125	1	67	002408	PIN,ROLL— .125 DIA. .750L	1
				68	056653	KNOB—PRES ADJ,MACH,EXTR	1
31	056551	GROM— .313ID,.750MHD,.125GROVE	2	69	026212	MTR,AC—115/230,60,.33HP,WIRED	1
32	004513	WSHR FLT .281 ID.875OD.036T ZN	2	70	035134	WDMT,PLATE W/NUT—KX15SC,KX19S	1
33	005620	SCR MACH RD HD .250-20X1.00,SS	2				
35	057591-24	PLT,STL—18GA, ACCESS COVER	1	71	035339	WDMT,TAKEUP—FRANKLIN MTR,BLK	1
				72	003249	SCR CAP HEX HD .312-18X1.25L	1

*VALVE KIT IS P/N 039571

BRUSH AND HEAD ASSEMBLY

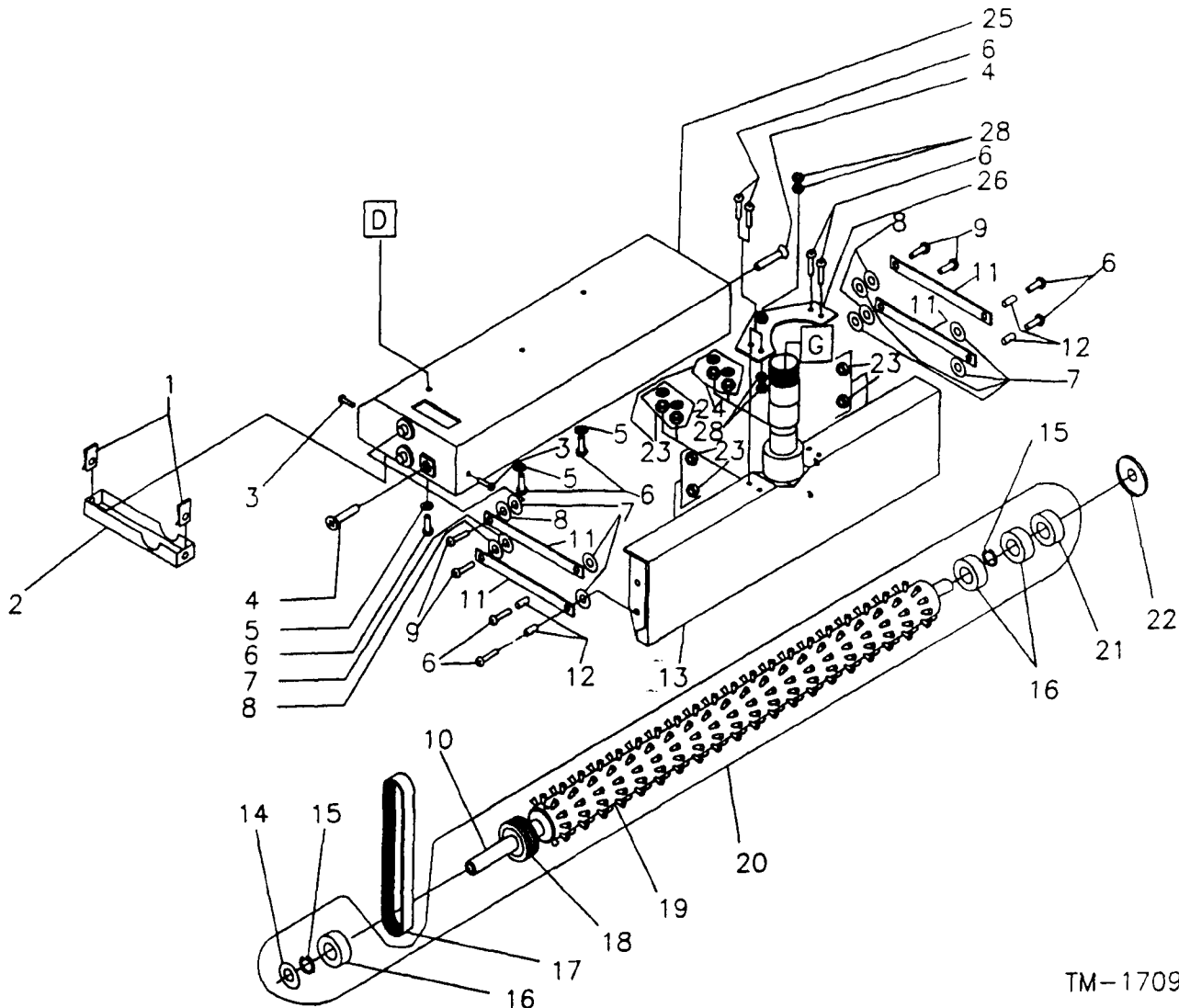

TM-1709

BRUSH AND HEAD ASSEMBLY PARTS LIST

DET. PART NO.	DESCRIPTION	QUANT.	DET. PART NO.	DESCRIPTION	QUANT.		
1	003413	NUT,SPEED.U— 10-24,.44X.63	2	15	051846	RING,RTNG—EXT. 375 SHAFT,STL	2
2	056772	BRACKET—20GA SPLASH GUARD	1	16	027197	BRG,BALL— .375ID. .875OD,.281W	3
3	005621	SCR MACH RD HD 10-24 X .312,SS	2	17	055114	BELT,V—6V'S. 19.00 PITCH LG	1
4	005511	SCR MACH FLAT HD 10-24X.5LSS	2	18	054799	PULLEY—BRUSH DRIVE,1.25OD,6GR	1
5	004536	WSHR LK .267ID.510OD.028T,SS	3	19	056559	BRUSH,CYL—2.25ODX13.465L	1
6	005620	SCR MACH RD HD .250-20X1.00,SS	11	20	035152	ASM,BRUSH—2.25OD CYL,13.465L	1
7	004320	WSHR SPR TNSN .375ID.750OD.014	8	21	054730	SEAL,GREASE— .875 OD X.375 ID	1
8	005219	WSHR FLT .406ID1.00OD.071T STL	4	22	055578	GUARD,THREAD—2.25 BRUSH	1
9	002478	SCR MACH RD HD .250-20X.375,SS	4	23	003468	NUT,HEX LOCK— 250-20,NYLOC,SS	4
10	056552	AXLE,BRUSH— .374ODX13.92L,KX15	1	24	004530	RIVET,TUBE— .141DIA.,.406L,SS	4
11	057050-24	BAR,STL— .625X.187X6.625,GRAY	4	25	035525-24	WDMT,EXTR HEAD—PNTD GRAY,15"	1
12	056522	BSHG,SLV— .277ID.375OD.263L,ST	4	26	035191-05	WDMT,LFT PLT—11GA,SS,PNTD BLK	1
13	057385-05	CSTG,VAC CHBR—PNTD,BLK	1	28	003438	NUT,HEX JAM— .375-16,SST	4
14	055588	SPACER,SEAL—2.25DIA BRUSH	1				

TM-1709L1

*If item 19 is ordered, item 18 is shipped with it automatically.

NOZZLE ASSEMBLY

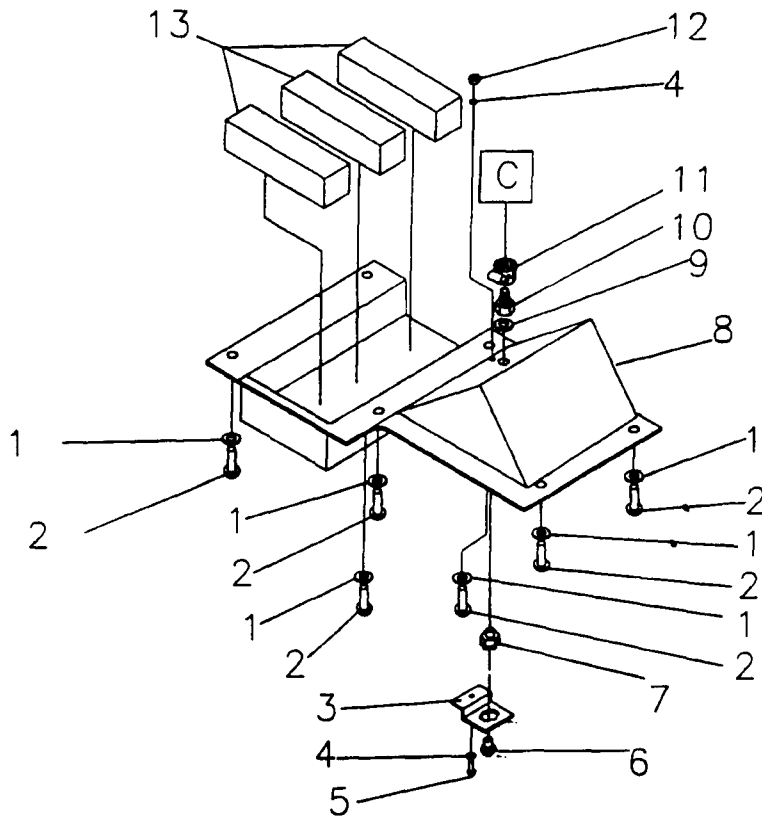

TM-1710

NOZZLE ASSEMBLY PARTS LIST

DET.	PART NO.	DESCRIPTION	QUANT.
1	005373	WSHR FLT .281ID.625OD.062T STL	6
2	005620	SCR MACH RD HD .250-20X1.00,SS	6
3	057594	BRKT,SS-16GA, NOZZLE HOLDER	1
4	004309	WSHR FLT .156ID.375OD.065T STL	2
5	005559	SCR NYL RD HD 6-32X.75L	1
6	057448	NOZZLE,TIP-95 DEG. W/FILTER	1
7	057447	NOZZLE,SPRAY-BODY & O-RING	1
8	057454	NOZZLE,SOUND CHAMBER-MOLDED	1
9	004499	WSHR FLT .594ID1.12OD.063T STL	1
10	006126	ADPTR,PP-HS-1/4 IPTX3/8HS,BRS	1
11	051581	CLAMP,HOSE-.625 MAX DIA,WORM	1
12	003274	NUT,HEX- 6-32,ZN PLT	1
13	057588	FOAM,POLYETHER-1.0X1.38X4.50	3

WIRING DIAGRAM

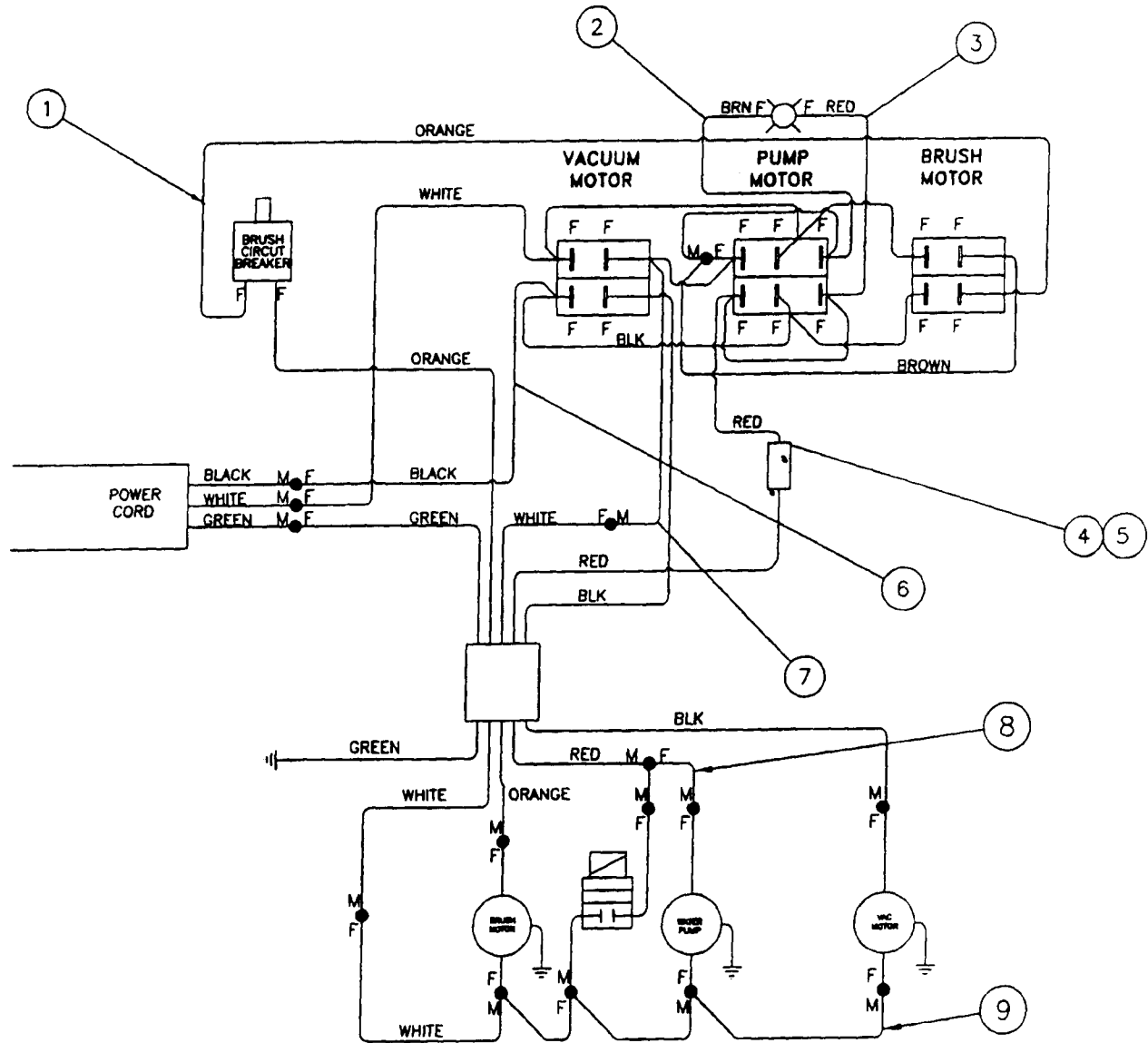

TM1706

WIRING PARTS LIST

DET.	PART NO.	DESCRIPTION	QUANT.
1	026197-4	ASM.WIRE—16GA,ORN,4.0L,FQDS	1
2	026222	ASM.WIRE—16GA,BRN,3CNDCT,QDS	1
3	026225	ASM.WIRE—16GA,RED,3CNDCT,QDS	1
4	R26096	HOLDER,FUSE—IN-LINE,18-12AWG	1
5	026211	FUSE—1A,SLOW BLOW	1
6	026224	ASM.WIRE—16GA,BLK,3CNDCT,QDS	1
7	026223	ASM.WIRE—16GA,WHT,3CNDCT,QDS	1
8	026004	ASM.WIRE—16GA,RED,2CNDCT,QD'S	1
9	026227	ASM.WIRE—16GA,WHT,4CNDCT,QDS	1

TM-1706L1